

LIGHT DUTY

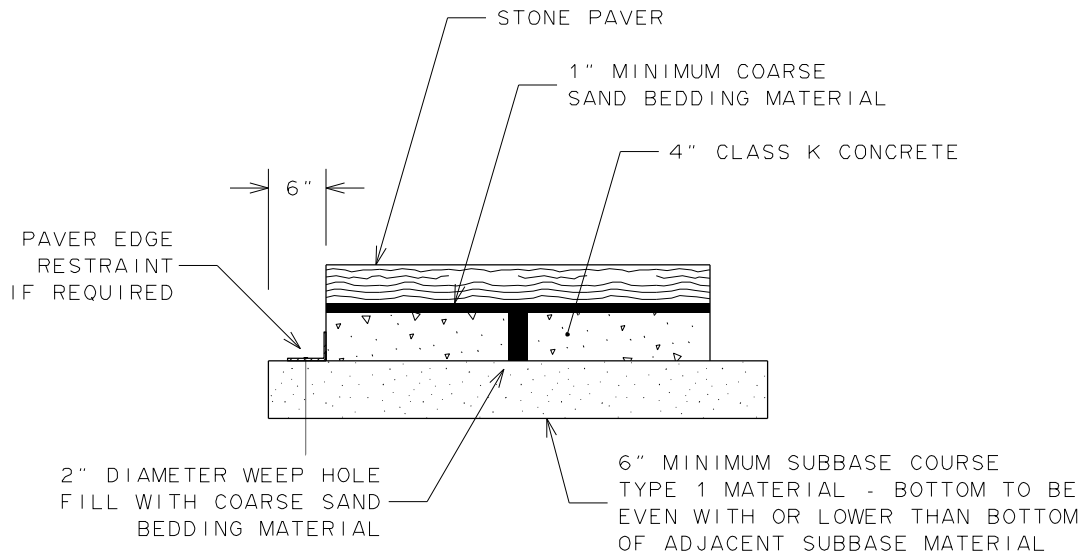

MEDIUM DUTY

NOTES:

1. CROSS SLOPE OF STONE PAVER SIDEWALK TO BE 1.50%.
2. SURFACE TO BE FIRM, STABLE AND SLIP-RESISTANT.
3. PROVIDE 1/2 INCH WIDE EXPANSION JOINT BETWEEN NEW STONE PAVER CONSTRUCTION AND OTHER PAVED SURFACES, STRUCTURES AND APPURTENANCES.
4. EXPANSION JOINT: 1/2 INCH WIDE PREMOULDED EXPANSION JOINT MATERIAL, SEAL TOP WITH CAULKING SEALANT 1/2 WIDE 5/8 INCH DEEP.
5. PROVIDE WEEP HOLE THRU CONCRETE FOUNDATION FOR EVERY 100 SQUARE FEET OF STONE PAVER AREA AND AT ALL LOW POINTS.
6. STONE PAVER SIDEWALK GRADE AND SURFACE TO BE MAINTAINED ACROSS DRIVEWAYS.

CITY OF ROCHESTER		
STONE PAVER		
ISSUED	9-2-91	STANDARD
REVISED	7-1-17	DWG.NO.R608-9