



**City Mark Capital Art Project  
City Response to Artist Questions  
July 17, 2024**

**WEBSITE**

Please note that the City of Rochester website recently went through a major upgrade. All materials related to this project should be located here:

<https://www.cityofrochester.gov/departments/department-environmental-services/rfq-city-mark-capital-art-project>

If you are experiencing issues with our website, please try clearing the cache and cookies on your internet browser. If you have further problems, please reach out to [ellen.soffa@cityofrochester.gov](mailto:ellen.soffa@cityofrochester.gov).

**CITY MARK LICENSING**

**Q1: We understand the City of Rochester is giving respondents a temporary license to use the City Mark in response to this RFQ. If the Artist is not selected, can they still use the designed artwork in their online portfolio?**

Yes, Artists can use any artwork designed for the City Mark submission containing the Rochester City Mark in their online portfolio whether the Artist is selected or not.

**Q2: It is noted that "With this RFQ, the City is granting parties that respond to the RFQ 'Respondents' the right to use the City Mark solely for the purpose of designing a work of public art in response to the RFQ." Does that permission extend to use of the City Mark in the Round 1 Submission Materials: h. Initial Vision concept sketch?**

Yes, Artists are allowed and encouraged to use the City Mark in concept sketches or other materials related to the submission.

**BUDGET**

**Q3: Are there any opportunities to increase the budget? Or if we can provide opportunities or funding would you be open to that?**

No, we will not be increasing the budget from what is listed in the RFQ. With the tight schedule, we do not have the flexibility to pursue other funding sources.

**ELIGIBILITY REQUIREMENTS**

**Q4: How firm is the \$200,000 requirement for submitting a proposal?**

The RFQ notes that the Artist must provide 3 references, including one for a project with a budget of \$200,000 or more. Dollar value is perhaps less important than capability and expertise. The City Mark project scope and schedule require an Artist with previous experience with sizable structural installations and comfort in working with engineers to design the manner of installation. We request that the Artist provide some description in the interest letter regarding their ability and experience with sizable structural installations.



**Q5: The required submission materials include a reference for at least one public art project with a budget of \$200,000 or more. May the reference be for a project completed by one of the team members to meet this requirement?**

Yes, it is acceptable for meeting the eligibility requirements if there is at least one member of the team who meets this requirement and the team has the capability and expertise to manage a sizable structural installation.

**Q6: Is the call open to international Artists?**

Yes, the call is open to international Artists, but please note that the finalist interviews will be in-person in Rochester, NY in early October 2024 (tentatively October 10-11 and 15-16, 2024).

**SITE PARAMETERS**

**Q7: Can you please provide scaled PDF drawings that show the entire plan and section of the bridge?**

Scaled drawings of the bridge will be provided to shortlisted Artists. It is our expectation that the selected Artist will work directly with a structural engineer licensed in the State of New York to coordinate installation, and can connect Artists with local engineering firms upon request.

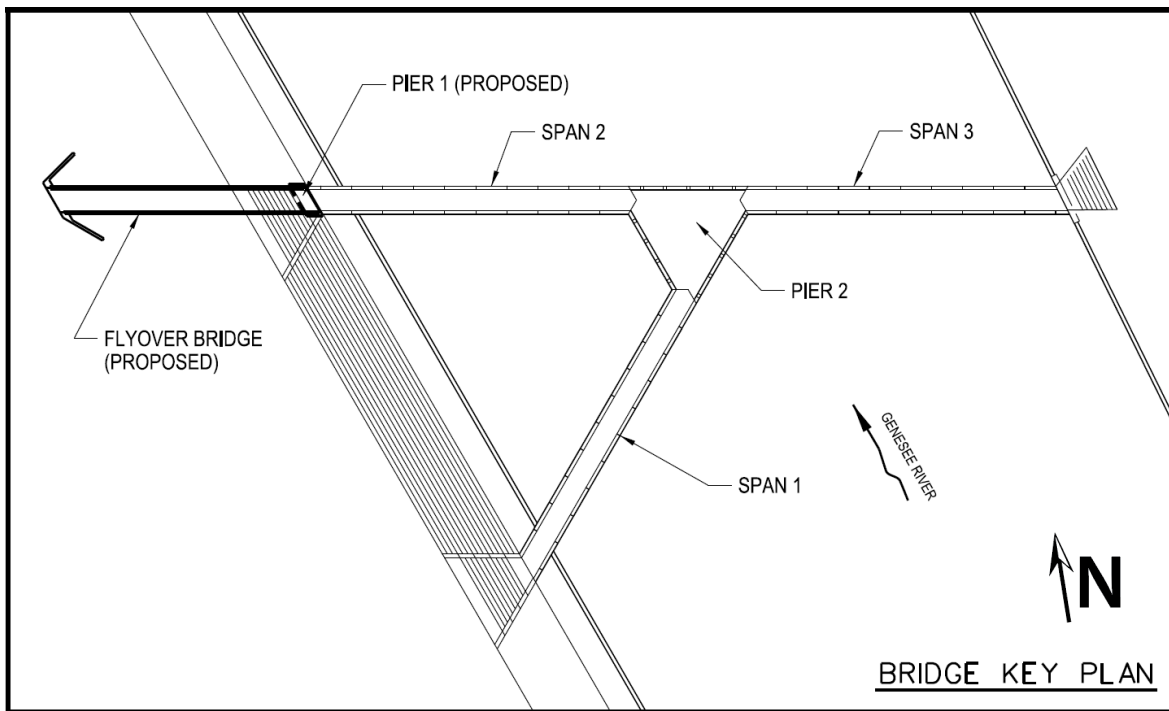

**Q8: What are the structural components under the bridge?**

In summary, the structural components under the bridge (noted in the diagram below) consist of:

- Span 1 & 3: Consist of post-tension concrete T-Beam. A four-inch concrete overlay is placed on top of the concrete T-Beam.
- Span 2: Consists of a post-tension concrete T-Beam. A three-inch concrete overlay is placed on top of the concrete T-Beam.
- Flyover Span: Consists of a six and a half inch concrete deck supported by steel beams.
- Pier 2 (Center pier located in river): Consists of a reinforced concrete pier founded on rock. The pier contains six sides, each side is angled and decreases in width as the elevation decreases.

**Q9: What utilities/infrastructure are built into the bridge that we need to coordinate with?**

- Spans 1, 2 & 3 contain post-tensioned cables and concrete reinforcement within the beam. Pier 2 also contains post-tensioned anchors and concrete reinforcement. Close coordination with a structural engineer licensed in the State of New York to prepare a plan for implementation is required before drilling into the structure.
- All electrical utilities for light poles are attached to the outside of the bridge and should not be affected with this project.

**Q10: What is the finished surface of the walkway?**

The walkway surface on bridge spans 1, 2, 3 and the center pier consist of a three to four inch concrete overlay. Portions of the concrete overlay contain an architectural finish that includes an integrally colored concrete with carbide seeded surface treatment. The City will work with the Artist to repair and maintain any coatings affected during installation.

**Q11: How can we securely attach our art piece to the bridge?**

Attachment to the bridge will require an engineer licensed in the State of New York to prepare and stamp a set of plans and calculations and submit the plan to the City for approval prior to any installation. The City will partner with the Artist to navigate any permitting requirements.

**Q12: Are there approximate weight, height, or overall dimension limitations for the focal point project?**

The bridge weight limit is 5.3 tons. The height and overall dimensions of the structure shall be determined by weight and stability calculations performed by an engineer licensed in the State of New York. Stability calculations shall take all applicable loading into account (e.g. wind, snow). The City does not wish to restrict the creativity of Artists in preparing their submissions. However, we offer the following parameters that will be required for maintenance, snow removal, pedestrians, and cyclists.

- **OVERHEAD CLEARANCE:** An overhead clearance of 10' above the walking surface is required on all pathways.
- **HORIZONTAL CLEARANCE WIDTH:** The route from the flyover bridge to span 2 and through span 3 (along north side) is the accessible route, and a horizontal clearance width of 8'8" needs to be maintained along this route. We recommend that the same horizontal clearance width is maintained along span 1 through the pier to span 3, but the minimum required clear width is 5'.

**Q13: Are there any weight limits requirements for installation equipment on the bridge?**

A load rating was performed on spans 1, 2 and 3. The maximum weight across the bridge shall be limited to 5.3 tons. The City is happy to help coordinate means and methods for installation.

**Q14: Are there any specific US Coastal navigational requirements or specifications for the water way under the bridge? Specifically any height or design restrictions?**

The section of the Genesee River under the Sister Cities Bridge is listed as a non-navigable waterway, there are not US Coastal navigation requirements. Rochester Gas & Electric (RG&E) controls the section of river under the bridge. The proposed artwork shall be no lower than the bridge deck, with the exception of structural attachments. The art installation needs to be on top of the bridge, not under/around the deck or pier.

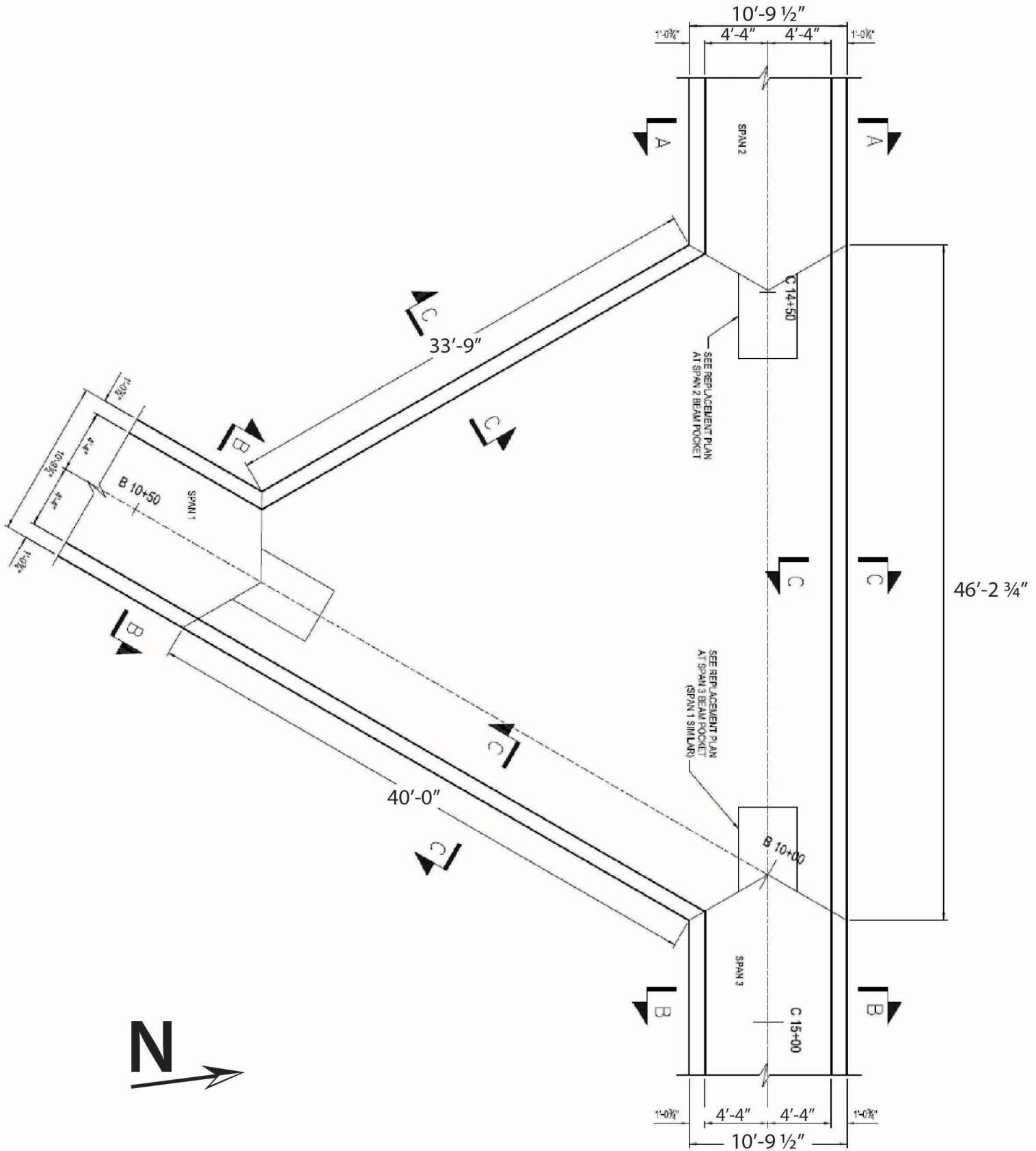

**Q15: Can you provide scaled PDF drawings of the parks on either side of the bridge, specifically the areas that were identified as potential secondary installation locations?**

As noted in the RFQ, the Artwork may also consider secondary locations to the east and west of the bridge, complementary to the focal point installation, as a means to enhance the east/west connectivity. The City will provide drawings to shortlisted Artists for the secondary installation locations, but can provide a bit more context to assist in developing concepts.

To the west, we envisioned possible locations along the State Street connection project. This walkway is now under construction with completion anticipated later in 2024. There are a variety of options along the corridor between State Street and the Sister Cities Bridge. The contract drawings for this project will be available to finalists. A rendering is included on page 17 of the RFQ.

To the east, we envisioned a potential location in Genesee Crossroads Park, which is currently in preliminary design with the start of construction anticipated in 2025 and completion in 2026. A conceptual plan will be released to the public in August, and will be made available to finalists. This location would require a different installation and completion schedule than the primary piece, since installation cannot occur prior to November 1, 2025. The City will help to identify a future location.

**Q16: What type of artwork does the project require - sculpture, statue, painting, mural, etc?**

The project requires a unique, prominent, iconic, and durable interpretation of Rochester's City Mark. The focal point of the installation will be in the center of the Sister Cities Bridge. The Artist can utilize any medium that would allow for a durable, stable, prominent installation.

We had envisioned something sculptural that would be anchored into the bridge structure, and are looking for a permanent physical artwork. As noted in the RFQ, the artwork must be designed for a publicly visible and accessible area; must be durable with respect to theft, vandalism, and the environment; and should not create an attractive nuisance, be climbable, or involve the use of water. The artwork should be permanent, to last a minimum of 30 years, outdoors, in local weather conditions and able to withstand interaction with the general public.

**CONTRACT REQUIREMENTS**

**Q17: Can you please provide more details on what is required by the Workers' Compensation Law of the State of New York and who that requirement is applicable to?**

No paperwork regarding workers' compensation is required at this time, and will only be needed if selected as a finalist. If the Artist is an individual with no employees or subcontractors, they are likely exempt and will need to submit the NYS CE-200 exemption form. If the Artist is using subcontractors to perform a portion of the project in NY (e.g., the installer of the artwork, other Artists) those subcontractors are required to have workers compensation/disability benefits coverage. If more information is needed, please contact [ellen.soffa@cityofrochester.gov](mailto:ellen.soffa@cityofrochester.gov) with specific details about your proposed team to coordinate a conversation with an attorney in the City's Law Department.

**Q18: In the Artist Stipend PSA Template, Section 11 notes the prohibition of subcontracting. Will finalist Artists be permitted to subcontract an engineer and/or project partners for consultation on the proposal?**

With respect to Section 11 of the Artist Stipend PSA Template, the note about subcontractors being prohibited is an error that will be revised in the final PSA to allow subcontracting.

**Q19: Will you require union labor for the installation?**

The City will not require union labor. Work performed off-site on the artwork or other materials fabricated off-site will not be subject to NYS prevailing wage. Work performed on-site is likely to be subject to prevailing wage. This determination will be made once more is known about the proposed artwork and the manner of installation. If more information is needed, please contact [ellen.soffa@cityofrochester.gov](mailto:ellen.soffa@cityofrochester.gov) with specific details about your proposed artwork to coordinate a conversation with a contract administrator in the City's Finance Office.

**Q20: Do Artists have to participate in the permitting process?**

Yes, but the City will partner with the Artist to navigate any permitting requirements and assist throughout the permitting process.

#### **SUBMISSION AND SELECTION PROCESS**

**Q21: The required submission materials for round 1 lists work samples twice: Item E "List of work samples, which shall include a brief description, location, and budget for each work (limit three pages total)" and item G "Work samples: up to ten (10) images of your recent projects, labeled as artist and work title". Are the ten (10) images allowed in item G in addition to the three pages allowed in item E?**

Yes, the ten images can be provided in addition to the three pages allowed in Item E.

**Q22: List of work samples, which shall include a brief description, location, and budget for each work (limit three pages total)." Is this request relative to request G: "Work samples: up to ten (10) images of your recent projects, labeled as Artist and work title" as an image inventory or is this more of a separate portfolio spread? The way it is presented, it seems like a portfolio doc request but, as there is no image inventory request, I am wondering if the request was just stated in an odd way.**

The City would like to receive written information (description, location, and budget) as well as visual information (images) regarding your previous work. If you prefer combining the written and visual information into portfolio pages/spreads, please limit the combined pages for both sections to 13 pages total (3 from Item E and 10 from Item G).

**Q23: Please confirm the submission information for Round 1 is to be mailed hard-copy courier or USPS, and not also emailed to your email address.**

Yes, proposals are to be submitted via hard copy, not by email. In the envelope with the hard copy, please provide a flash drive with a digital copy of all materials.

**Q24: Are finalist interviews to be facilitated virtually or in person?**

Finalist interviews will be in-person in Rochester, NY in early October 2024. Shortlisted Artists are required to be available in early October 2024 (tentatively October 10-11 and 15-16, 2024).

**MORE INFORMATION**

**Q25: Can you publish high resolution photos of the location?**

Yes, some high resolution photos have been posted to the City Mark page of the City of Rochester website, and can be found here:

<https://www.cityofrochester.gov/departments/department-environmental-services/rfq-city-mark-capital-art-project>

**Q26: Can you publish the link to the info session video? Where can applicants find the zoom information session recording?**

Yes, the link to the info session has been posted to the City Mark page of the City of Rochester website, and can be found here: <https://www.cityofrochester.gov/departments/department-environmental-services/rfq-city-mark-capital-art-project>

**Q27: Where can applicants find the site visit schedule? If no upcoming site visits are currently scheduled, how can I schedule a site visit?**

There is no official site visit schedule. The project manager is organizing site visits upon request by interested Artists. The project site is now officially open, so scheduling a site visit is not required. If interested in scheduling a site visit, please contact project manager Ellen Micoli Soffa at [ellen.soffa@cityofrochester.gov](mailto:ellen.soffa@cityofrochester.gov).