



(Oct 2024)

SELF-SERVE PERMITTING INSTRUCTIONS

RESIDENTIAL GARAGES AND CARPORTS

HELPFUL INFORMATION:

- Your request is subject to compliance with both the NY State Building Code and the City Zoning Code, and each code may regulate your request differently.
- A residential garage is an accessory structure for the parking of vehicles.
- Detached garages and carports must be located in rear yard and cannot have a footprint larger than the house.
- Attached and detached garages have various setbacks for all yards. It is best call Zoning at (585) 428-7043 for this information.
- The overall height of a garage cannot exceed 15'.
- Garages and carports cannot be used for commercial purposes.

MINIMUM SUBMISSION REQUIREMENTS:

- ✓ Complete permit application (attached)
- ✓ Instrument Survey Map showing proposed location (example attached)
- ✓ Framing, floor, and elevation plans (examples attached)
- ✓ Workers' Comp or waiver if applicable (see attached)
- ✓ Fee based on labor and materials (fee schedule attached; checks, money order with checks payable to "City Treasurer")

HOW TO SUBMIT: Your completed permit application package can be submitted by:

- Email: zoning@cityofrochester.gov
- In person Monday, Wednesday, Friday 9am - 4pm only
- **Closed to walk-ins Tuesdays and Thursdays**
- Drop box provided at City Hall A Building lobby
- Mail: The Bureau of Zoning & Permitting
30 Church Street, Room 121B
Rochester, NY 14614

If you have questions, email: zoning@cityofrochester.gov or call (585) 428-7043 for additional instructions. **Incomplete application submissions will be returned.**
Thank you.





BUILDING PERMIT APPLICATION and ZONING COMPLIANCE REQUEST

PROPERTY ADDRESS: _____

USE: RESIDENTIAL (1 or 2 Family) COMMERCIAL MIXED USE

APPLICANT INFORMATION:

YOUR NAME: _____ YOUR PHONE NUMBER: _____
(not a company name)

YOUR EMAIL ADDRESS: _____

YOUR MAILING ADDRESS: _____

PROPERTY OWNER:

Check if same as applicant above

Name: _____

Address: _____
(Cannot be a PO Box) (include City or Town)

Zip: _____ Phone: _____

Email: _____

CONTRACTOR: (check if same as:)

Owner Applicant (check both if applicable)

Name: _____

Address: _____
(Cannot be a PO Box) (include City or Town)

Zip: _____ Phone: _____

Email: _____

ARCHITECT: _____
OR ENGINEER

PERMIT REQUEST:

DESCRIPTION: _____

- ADDITION/NEW CONSTRUCTION INTERIOR RENOVATIONS EXTERIOR RENOVATIONS
- CHANGE/ESTABLISH USE DECK POOL/HOT TUB SHED/GARAGE/CARPORT
- HVAC/MECHANICAL/ELECTRICAL SYSTEMS OTHER: _____

PROJECT COST ESTIMATE: (excluding plumbing & electrical) \$ _____

YOUR SIGNATURE: _____

DATE: _____

Residential Garage and Carport Permits

(assumed to be detached from principal structure /house)

Drawings/Framing plans

Buying a Pre-Made Garage or Carport -Or- Garage or Carport Kit with Parts from a Store

Please provide the following information:

1. Brochure or Plans from manufacturer of garage or carport Specifications

Constructing A Garage or Carport

(without pre-made parts)

1. Construction drawings: should include the following and be drawn to scale (1/4" per foot preferred) - Plan view (overhead), Elevations of all sides and Cross section/vertical slice (side view) with dimensions and notes of all materials:
 - a. Include title block with project location (address) & contact phone # on plan
 - b. Foundation/ Footings / Slab On Grade – as applicable
 - c. Wall Framing size & on center spacing
 - d. Header size over all openings (window & door)
 - e. Rafters size & on center spacing
 - f. Wall ties on center spacing
 - g. Footer/Foundation details & dimensions
 - h. Width, length & roof pitch and midpoint height

Garage or Carport Code Requirements:

- Building Permit – new or replacement detached garages or carports - two sets of building plans are required as part of the building permit application
- Garage or Carport Location & Distance:
 - Setback Distance: Garage or carport must be located in the rear yard
 - Setback Definition: setback measurements shall be minimum horizontal distance measured from garage or carport structure or any projections, whichever is greater, to the closest point of rear and side properties lines
 - Rear and side Lot Lines: Garage or carport must be at least 5 feet from rear and side lot lines (interior lot lines shared by adjoining properties) for zero rated wall construction (*IRC Section R302.1 & Table R302.1(1)*)
 - Distance closer than 5 feet to lot lines: exterior walls shall be protected from fire spread with a minimum fire-resistance rating of 1 hour – tested in accordance with ASTM E119 or UL 263 with exposure from both sides (*IRC Section R302.1 & Table R302.1(1)*)
 - Floor surface: garage floor surfaces shall be of approved noncombustible material (asphalt not permitted). The area of floor used for parking of automobiles or other

vehicles shall be sloped to facilitate the movement of liquids to a drain or toward the main vehicle entry doorway. *(IRC Section R309.1)*

- o Carports shall be open on not less than two sides. Carports not open on two or more sides shall be considered to be a garage and shall comply with the provisions for garages.

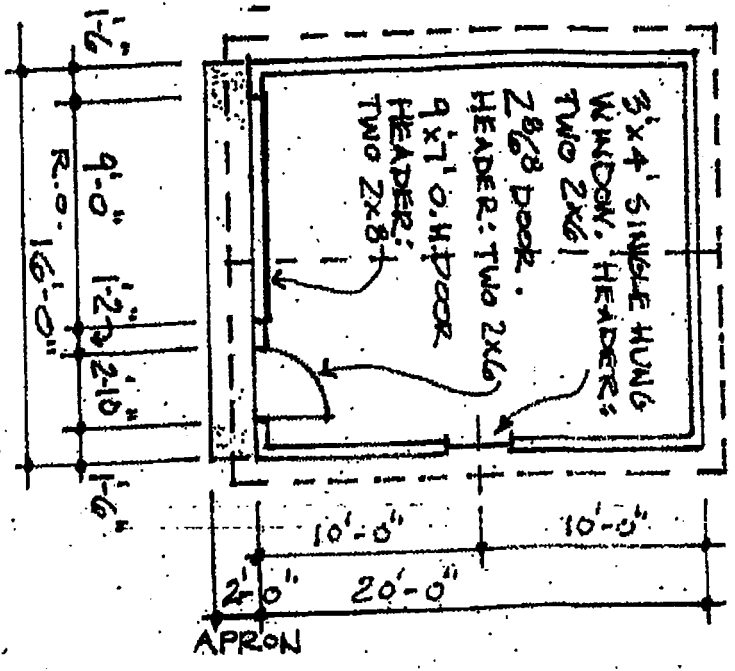

FLOOR PLAN
1/8" = 1'-0"

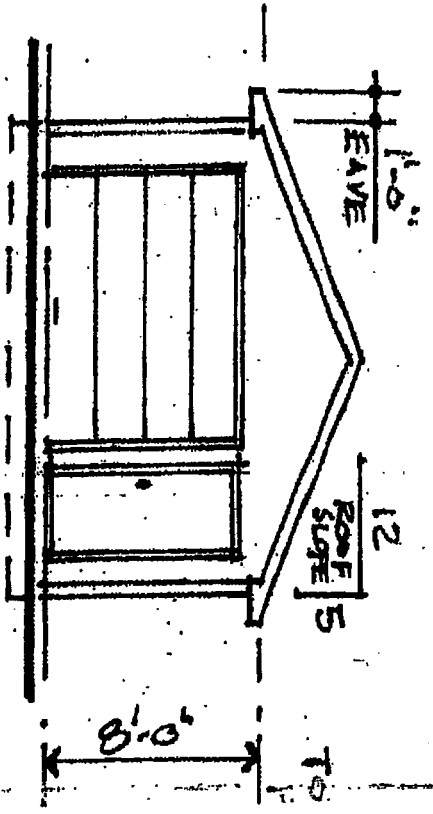

FRONT ELEVATION

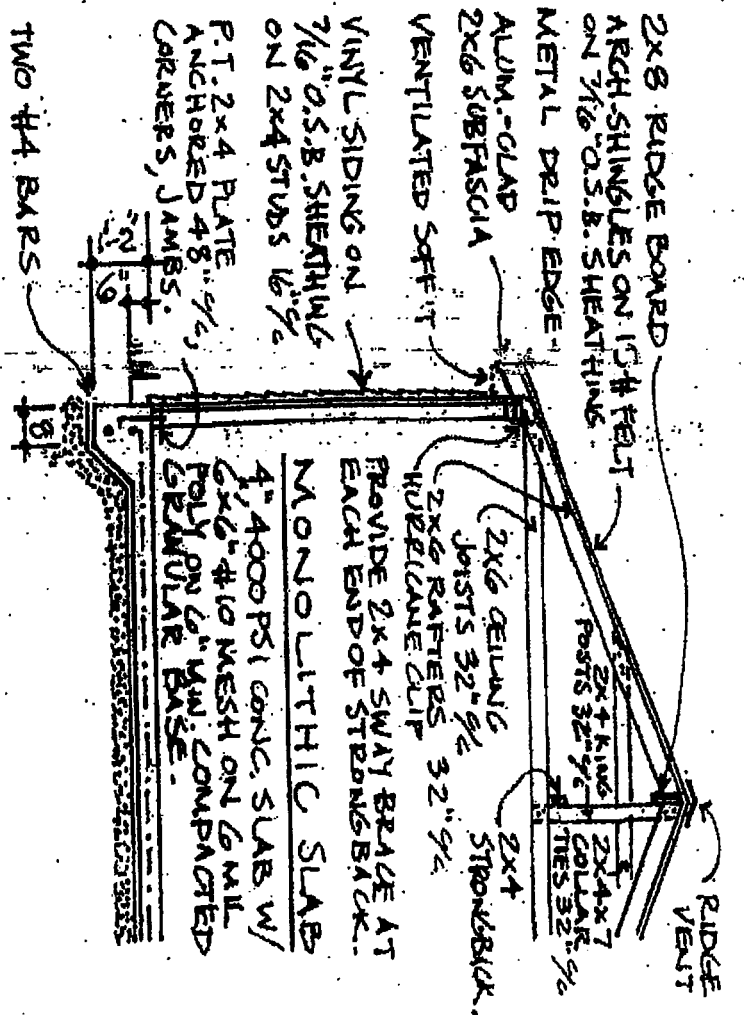

SECTION
1/4" = 1'-0"

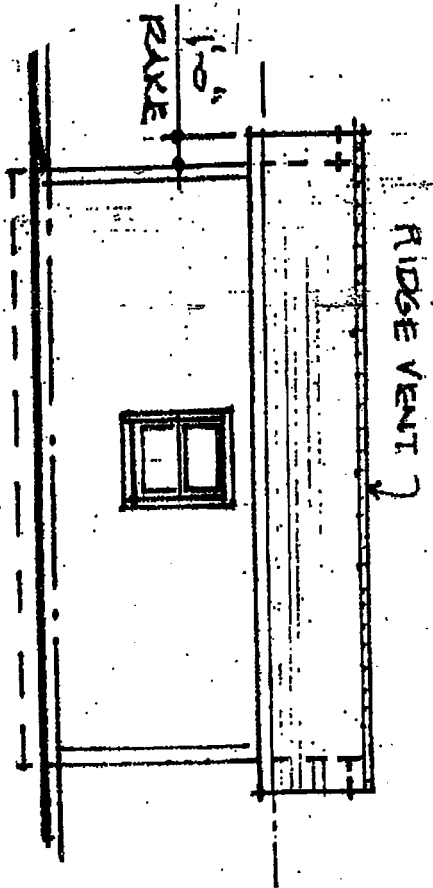

RIGHT ELEVATION

Slab-on-Ground Construction: Floating Slab Foundation

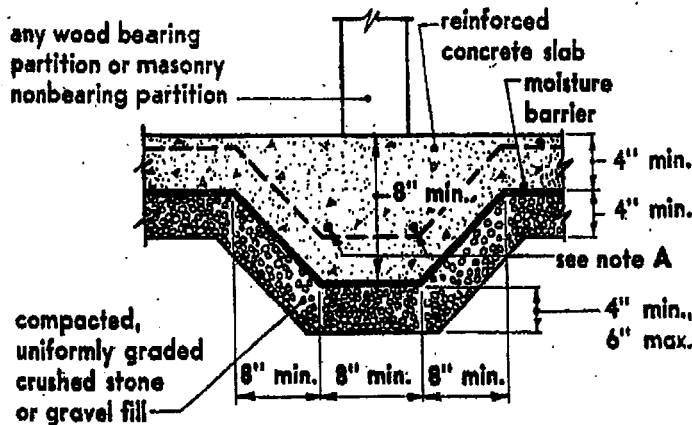
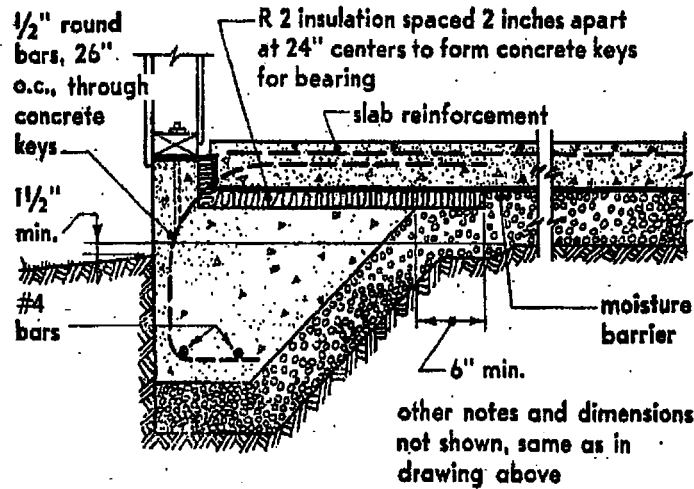
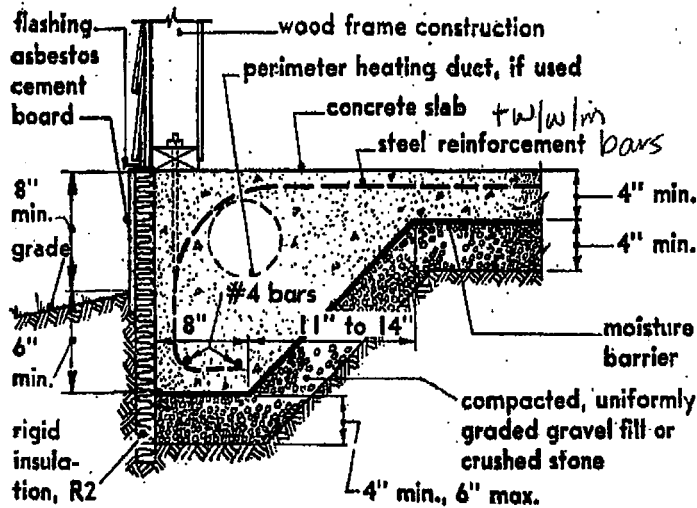

Constructions illustrated are for wood frame buildings with heights of 12-foot maximum from floor to eave and 20-foot maximum from floor to gable peak.

For concrete and concrete reinforcement requirements, see text entitled, "Concrete," part 3, page 16, and "Reinforced Concrete," part 3, page 39.

For anchorage of wood sill to foundation, see illustration entitled, "Anchors and Nailing for Exterior Stud Walls," part 3, page 71.

Protection Against Frost Action—The adjoining ground is to slope away from the foundation in all directions, and the underlying soil should preferably be sand or gravel to reduce to a minimum heaving due to frost action. Silty sand or clay soil should be avoided. For perimeter wall foundation, bottom of footing is to be below frost line. If necessary, footing drains or other means that would reduce height of water table below the slab may be installed. For footing drains see illustration entitled, "Foundation Dampproofing and Waterproofing," part 3, page 11.

Note A: two #4 bars for wood bearing partition if one story; two #5 bars for wood bearing partition if two stories and for masonry nonbearing partitions; masonry bearing partitions are to be supported on separate foundations.

For additional requirements, see text entitled, "Concrete Slabs on Soil," part 3, page 10.

SAMPLE INSTRUMENT SURVEY MAP

NOTE:

- This is a sample of an Instrument Survey Map.
- The property owner should have received a copy at their closing.
- If you do not have one, you can check with your mortgage company or the attorney who handled your closing.
- The City does not keep copies of Instrument Survey maps.
- If you need to have a new one made, you need to call a Land Surveyor.

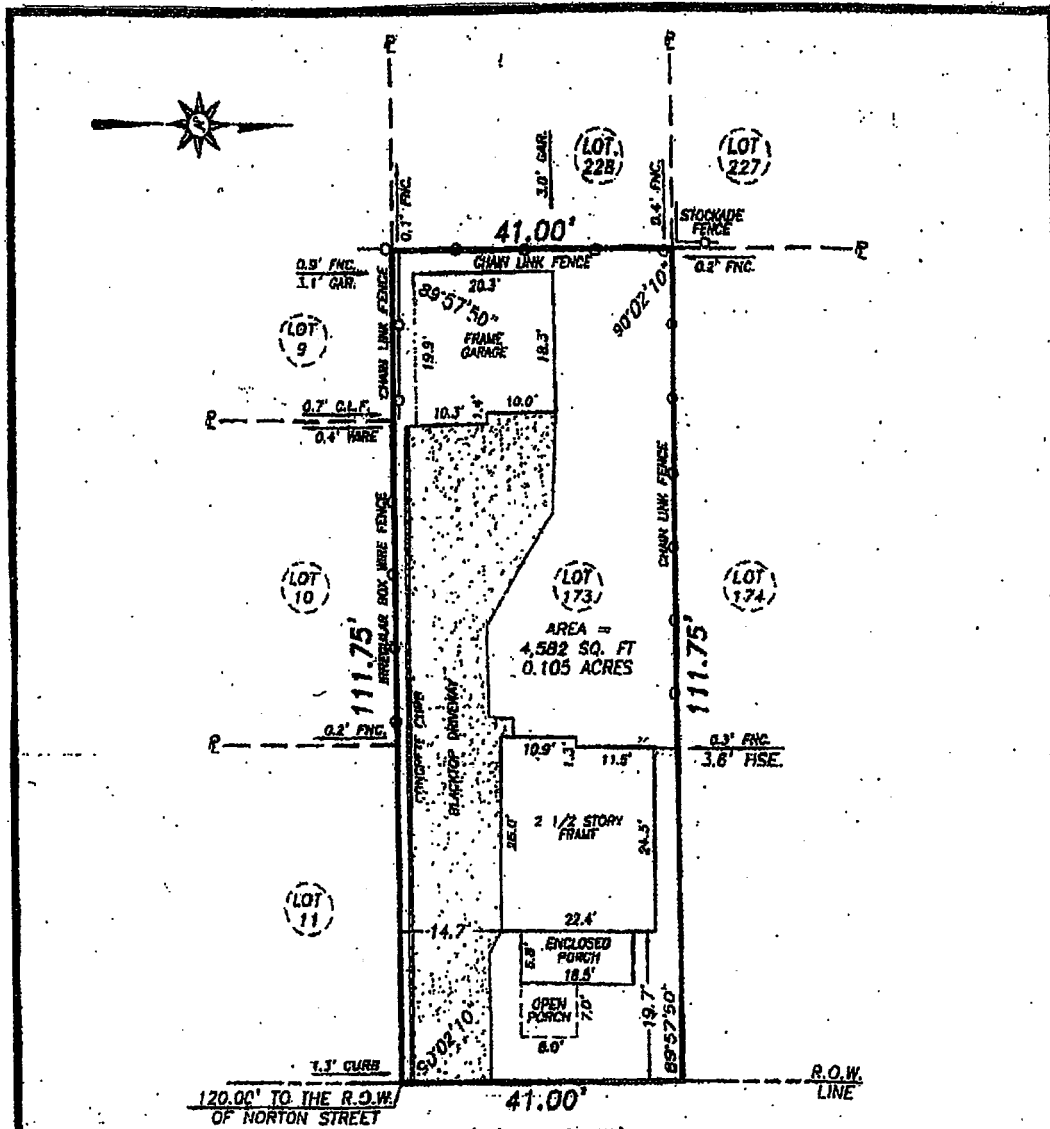

CERTIFICATION:

I, DAVID A. STAUB, HEREBY CERTIFY TO:
 -DESISPEE RODRIGUEZ-MENDEZ
 -HARVEY S. BUNIS, ESQ.
 -THE BANK OF CASTLE, ITS SUCCESSORS AND/OR ASSIGNS
 -UNDERBERG & KESSLER, LLP
 -THE TITLE INSURANCE COMPANY INSURING THE MORTGAGE

THAT THIS MAP WAS MADE OCTOBER 19, 2017
 FROM NOTES OF AN INSTRUMENT SURVEY
 COMPLETED OCTOBER 3, 2017
 AND REFERENCES LISTED HEREON.

REFERENCES:

- 1.) LIBER 39 OF MAPS, PAGE 5.
- 2.) LIBER 11058 OF DEEDS, PAGE 59.
- 3.) ABSTRACT OF TITLE No. 412329 (FIRST AMERICAN).

NOTES: 1.) PREMISES SUBJECT TO ALL EASEMENTS, RESTRICTIONS & COVENANTS OF RECORD NOT REFERENCED IN ABSTRACT OF TITLE.
 2.) THE USE OF THIS MAP IN CONJUNCTION WITH AN AFFIDAVIT OF NO CHANGES, RELEASES THE SURVEYOR OF ALL RESPONSIBILITY.

N.Y.S.L.S. No. 50791 DATE

TITLE: INSTRUMENT SURVEY MAP

BEING LOT No.
 OF THE RALEIGH SUBDIVISION,
 CITY OF ROCHESTER, COUNTY OF MONROE, STATE OF NEW YORK

This instrument is a copy of a survey map bearing a licensed land surveyor's seal and is a violation of Section 7208, sub-section 2, of the New York State Education Law.

*Only copies from the original of this survey received with an original of the land surveyor's seal and shall be considered to be valid true copies.

*Certification is required herein, stating that this survey was prepared in accordance with the existing Code of Practice for Land Surveying adopted by the New York State Association of Professional Land Surveyors. Said certification shall not only be the basis for whom the survey is prepared, but also shall be the basis for the title insurance, professional liability and liability insurance, and shall be the basis for the land surveyor's certification. Certifications are not required in additional jurisdictions or subsequent work.

*An electronic file of Triple Point Land Surveying, LLC. was sent to the property owner, Triple Point Land Surveying, LLC. Said electronic file may not be admitted at any time by either party for any purpose whatsoever.

TRIPLE POINT LAND SURVEYING, LLC.
 16 EAST MAIN STREET SUITE 320
 ROCHESTER, NEW YORK 14614
 PHONE (585) 263-9950
 FAX (585) 263-3581
 TRIPLEPOINTSURVEYING@YAHOO.COM

SCALE: 1" = 20' TAX ACCOUNT: 0164-1-12 JOB NO: 1429-17 DATE: OCT 19 2017

WORKERS' COMPENSATION INSURANCE

The State of New York requires that, prior to issuing any permits, the City of Rochester be provided with proof of Workers' Compensation Insurance coverage or provide proof of exemption from such coverage.

One of the following certificates must be provided by the applicant with each permit request:

- C105.2 or U-26.2 – Workers' Compensation Insurance (private carrier)
(contractor with employees)
- CE-200 – Exemption Certificate
(contractor with no employees)
- BP-1 – Affidavit of Exemption
(owner occupied 1-4 family & owner is performing work)
- SI12 or GSI-105.2 – Self Insurance coverage

Helpful Hints:

- To obtain a CE 200 Exemption
 - <https://www.businessexpress.ny.gov/>
 - Worker's Compensation Board location at 130 W. Main Street (verify if open by calling 1-877-632-4996)
- Certificates for building permits are job-specific and a separate certificate will be required for each building permit.
- NYS does NOT accept "ACORD" Certificates nor will they accept faxed copies.

CITY OF ROCHESTER
BUILDING PERMIT FEES
AS OF JULY 1ST, 2018

PROJECT COST		FEE		PROJECT COST		FEE
\$0	\$ 2,000	\$50		\$30,000	\$32,000	\$350
2,001	4,000	70		32,001	34,000	370
4,001	6,000	90		34,001	36,000	390
6,001	8,000	110		36,001	38,000	410
8,001	10,000	130		38,001	40,000	430
10,001	12,000	150		40,001	42,000	450
12,001	14,000	170		42,001	44,000	470
14,001	16,000	190		44,001	46,000	490
16,001	18,000	210		46,001	48,000	510
18,001	20,000	230		48,001	50,000	530
20,001	22,000	250		50,001	52,000	550
22,001	24,000	270		52,001	54,000	570
24,001	26,000	290		54,001	56,000	590
26,001	28,000	310		56,001	58,000	610
28,001	30,000	330		58,001	60,000	630

FORMULAS	
\$ 60,000 to 100,000	$.009 \times \text{Cost} + 150 = \text{Fee}$
\$ 100,001 to 500,000	$.007 \times \text{Cost} + 375 = \text{Fee}$
\$ 500,001 to 1,000,000	$.005 \times \text{Cost} + 1,475 = \text{Fee}$
\$ 1,000,001 and over	$.003 \times \text{Cost} + 3,675 = \text{Fee}$