

PLAN

SAW CUT PAVEMENT FULL DEPTH
DO NOT OVER CUT CORNERS
SEAL EDGES WITH NYS DOT
705-02 HIGHWAY JOINT SEALANT
(SEE NOTE 6)

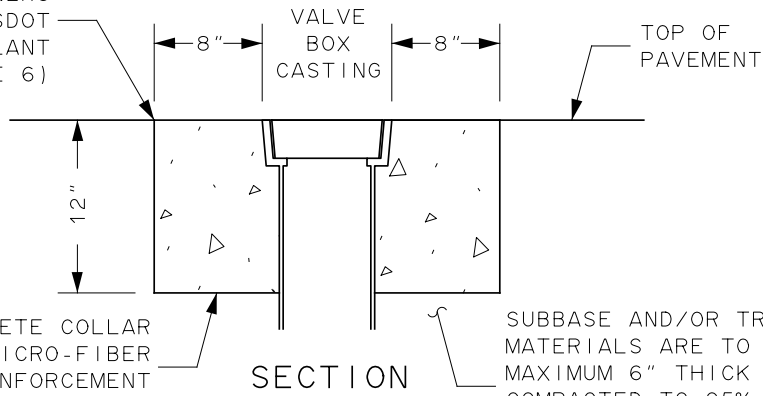

SECTION

SUBBASE AND/OR TRENCH BACKFILL
MATERIALS ARE TO BE PLACED IN
MAXIMUM 6" THICK LAYERS AND
COMPACTED TO 95% OF MODIFIED
PROCTOR MAXIMUM DRY DENSITY TEST
IN ACCORDANCE WITH ASTM D1557

NOTES:

1. CASTING AND TOP OF CONCRETE ARE TO BE IN SAME HORIZONTAL PLANE AS SURROUNDING SURFACE, TRUE TO LINE AND GRADE, WITH COVER HAVING FULL CONTINUOUS AND UNIFORM BEARING CONTACT WITH FRAME.
2. TOP OF COVER IS TO BE LEVEL WITH TOP OF FRAME, STABLE AND IMMOVABLE WHEN IN PLACE AND WHEN UNDER INFLUENCE OF TRAFFIC OR ANY OTHER TYPE OF LOAD BEARING STRESS.
3. IF CASTING IS BELOW/ABOVE TOP OF SURROUNDING SURFACE GREATER THAN 1/4 INCH, IT IS DEFICIENT CONDITION THAT MUST BE MITIGATED PER DETAIL S100-01 OF "RULES AND REGULATIONS FOR WORK IN THE RIGHT-OF-WAY".
4. HIGH EARLY STRENGTH CONCRETE IS TO BE USED FOR PLACEMENTS REQUIRED TO SATISFY OPEN TO TRAFFIC TIME REQUIREMENTS.
5. DURING AND AFTER DEPOSITION OF CONCRETE PERFORM MODERATE VIBRATION AND COMPACTION TO EXPUL LARGE BUBBLES AND EXCESS OF ENTRAPPED AIR FROM FRESHLY PLACED CONCRETE IN ACCORDANCE WITH NYS DOT SECTION 555-3.04 HANDLING AND PLACING CONCRETE.
6. SEALANT IS TO BE HOT-APPLIED ASPHALT PRODUCT SUCH AS CRAFTCO ROADSaver 201, CRAFTCO ROADSaver 231, OR APPROVED EQUIVALENT.
7. IF PAVEMENT IS CUT AND CORE LEFT IN PLACE FOR REMOVAL AT LATER TIME VOIDS ARE TO BE FILLED-IN WITH ASPHALT COLD PATCH OR MILLINGS. VOIDS ARE NOT TO BE LEFT OPEN OVERNIGHT.
8. SQUARE OR ROUND SHAPED COLLAR MAY BE USED AT NO ADDITIONAL COST TO CITY - SEE DETAIL S909-4. SAME SHAPE MUST BE USED ON ENTIRE PROJECT EXCEPT IN CASES OF SPECIAL CIRCUMSTANCES WHERE DIFFERENT SHAPE MAY BE NECESSARY DUE TO PHYSICAL CONSTRAINTS AND AS APPROVED BY PROJECT MANAGER.

CITY OF ROCHESTER		
<p>SQUARE CONCRETE COLLAR FOR VALVE BOX WITHIN ROADWAY</p>		
ISSUED	6-24-19	NON-STANDARD DWG.NO.S909-3
REVISED	12-10-21	