



INNER LOOP EAST TRANSFORMATION PROJECT

REMOVE • RESTORE • RECONNECT • REVITALIZE

FINAL DESIGN REPORT – Volume 1

PIN 4940.T7

MARCH 2014



City of Rochester, Department of Environmental Services



New York State Department of Transportation



Federal Highway Administration



Stantec



PROJECT APPROVAL SHEET

(Pursuant to SAFETEA-LU Matrix)

A. IPP Approval: The project is ready to be added to the Regional Capital Program and scoping can begin.
The IPP was approved by:
Charles Moynihan 9-7-2001
Regional Director, NYSDOT Region 4

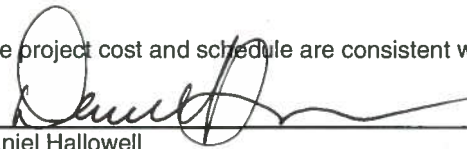
B. Scoping Approval: The project cost and schedule are consistent with the Regional Capital Program.
The Scope was approved by:
James R. McIntosh, P.E., 9-2013
City Engineer

C. Recommendation for Design Approval: The project cost and schedule are consistent with the Regional Capital Program.

Daniel Hallowell 3/19/14
Regional Program and Planning Manager – NYSDOT Region 4

D. Recommendation for Design and Nonstandard Feature Approval: All requirements requisite to these actions and approvals have been met, the required independent quality control reviews separate from the functional group reviews have been accomplished, and the work is consistent with established standards, policies, regulations and procedures, except as otherwise noted and explained.

James R. McIntosh, P.E., 3/19/14
City Engineer

for Kevin Bush, P.E., 3/19/14
Regional Director – NYSDOT Region 4

E. Nonstandard Feature Approval: The nonstandard features have been adequately justified and it is not prudent to eliminate them as part of this project.
Refer to Appendix O for Approval Letter 3/19/14
Hans Anker, P.E.,
Area Engineer - FHWA

F. Design Approval: The required environmental determinations have been made and the preferred alternative for this project is ready for final design.
Refer to Appendix O for Approval Letter 3/19/14
Hans Anker, P.E.,
Area Engineer - FHWA

LIST OF PREPARERS

Group Director Responsible for Production of the Design Approval Document:

James R. Hofmann, Jr., P.E., Principal, Stantec Consulting Services Inc.

Description of Work Performed: Directed the preparation of the Design Approval Document in accordance with established standards, policies, regulations and procedures, except as otherwise explained in this document.



Note: It is a violation of law for any person, unless they are acting under the direction of a licensed professional engineer, architect, landscape architect, or land surveyor, to alter an item in any way. If an item bearing the stamp of a licensed professional is altered, the altering engineer, architect, landscape architect, or land surveyor shall stamp the document and include the notation "altered by" followed by their signature, the date of such alteration, and a specific description of the alteration.

TABLE OF CONTENTS

COVER..... i

PROJECT APPROVAL SHEETiii

LIST OF PREPARERSiv

TABLE OF CONTENTS v

CHAPTER 1 - EXECUTIVE SUMMARY 1-1

1.1. Introduction 1-1

1.2. Purpose and Need 1-1

 1.2.1. *Where is the Project Located?* 1-1

 1.2.2. *Why is the Project Needed?* 1-5

 1.2.3. *What are the Objectives/Purposes of the Project?* 1-5

1.3. What Alternative(s) Are Being Considered? 1-6

1.4 How will the Alternative(s) Affect the Environment? 1-8

1.5. What Are The Costs & Schedules? 1-9

1.6. Which Alternative is Preferred? 1-9

1.7. What are the Opportunities for Public Involvement? 1-10

CHAPTER 2 - PROJECT CONTEXT: HISTORY, TRANSPORTATION PLANS, CONDITIONS AND NEEDS 2-1

2.1. Project History 2-1

2.2. Transportation Plans and Land Use 2-2

 2.2.1. *Local Plans for the Project Area* 2-2

 2.2.2. *Transportation Corridor* 2-3

2.3. Transportation Conditions, Deficiencies and Engineering Considerations 2-5

 2.3.1. *Operations (Traffic and Safety) & Maintenance* 2-5

 2.3.2. *Multimodal* 2-13

 2.3.3. *Infrastructure* 2-15

 2.3.4. *Potential Enhancement Opportunities* 2-24

 2.3.5. *Miscellaneous* 2-25

CHAPTER 3 – ALTERNATIVES 3-1

3.1. Alternatives Considered and Eliminated from Further Study 3-1

3.2. Feasible Build Alternatives 3-1

 3.2.1. *Description of Feasible Alternatives* 3-1

 3.2.2. *Preferred Alternative* 3-2

 3.2.3. *Design Criteria for Feasible Alternative(s)* 3-3

3.3. Engineering Considerations 3-9

 3.3.1. *Operations (Traffic and Safety) & Maintenance* 3-9

 3.3.2. *Multimodal* 3-16

 3.3.3. *Infrastructure* 3-16

 3.3.4. *Landscape and Environmental Enhancements* 3-21

 3.3.5. *Miscellaneous* 3-21

CHAPTER 4 - SOCIAL, ECONOMIC AND ENVIRONMENTAL CONDITIONS AND CONSEQUENCES4-1

4.1 Introduction 4-1

 4.1.1 *Environmental Classification* 4-1

 4.1.2 *Coordination with Agencies* 4-1

4.2 Social 4-1

 4.2.1 *Land Use* 4-2

 4.2.2 *Neighborhoods and Community Cohesion* 4-3

 4.2.3 *Social Groups Benefited or Harmed* 4-3

 4.2.4 *School Districts, Recreational Areas, and Places of Worship* 4-5

4.3 Economic 4-6

 4.3.1 *Regional and Local Economies* 4-6

4.3.2 Business Districts 4-7

4.3.3 Specific Business Impacts..... 4-7

4.4 Environmental 4-8

4.4.1 Wetlands..... 4-8

4.4.2 Surface Waterbodies and Watercourses..... 4-8

4.4.3 Wild, Scenic, and Recreational Rivers 4-9

4.4.4 Navigable Waters 4-9

4.4.5 Floodplains 4-10

4.4.6 Coastal Resources 4-10

4.4.7 Groundwater Resources, Aquifers, and Reservoirs..... 4-11

4.4.8 Stormwater Management 4-11

4.4.9 General Ecology and Wildlife Resources 4-11

4.4.10 Critical Environmental Areas 4-12

4.4.11 Historic and Cultural Resources..... 4-13

4.4.12 Parks and Recreational Resources..... 4-15

4.4.13 Visual Resources..... 4-16

4.4.14 Farmlands..... 4-17

4.4.15 Air Quality..... 4-17

4.4.16 Energy and Greenhouse Gas..... 4-18

4.4.17 Noise..... 4-18

4.4.18 Asbestos 4-19

4.4.19 Hazardous Waste and Contaminated Materials..... 4-22

4.5 Construction Effects 4-23

4.5.1 Construction Impacts..... 4-23

4.5.2 Mitigation Measures 4-23

4.6 Indirect and Secondary Effects 4-24

4.7 Cumulative Effects 4-24

4.8 Irreversible and Irrecoverable Commitments of Resources..... 4-24

4.9 Adverse Environmental Impacts that cannot be Avoided or Adequately Mitigated 4-24

CHAPTER 5 – PUBLIC HEARING COMMENTS AND RESPONSES 5-1

5.1 Oral Comments Received at the February 4, 2014 Public Hearing 5-1

5.1.1 Michael Knight, Buena Place 5-1

5.1.2 Steven Venturino, South Union Street 5-1

5.1.3 Dawn Williams-Fuller, Ambassador Union Street, LLC..... 5-1

5.1.4 Joey Lanzone, staff writer for Roc Insomniac 5-1

5.1.5 Jack Darcy, property owner within project area 5-2

5.1.6 Chris McCamic, Buena Place..... 5-2

5.1.7 Edward Steinberg, Lafayette Park..... 5-2

5.2 Written Comments Received at the February 4, 2014 Public Hearing 5-3

5.3 Written Comments Received via E-Mail Following the Public Hearing..... 5-3

5.3.1 Anthony Mittiga..... 5-3

5.3.2 Colleen McCarthy, Lock 66 Neighborhood Association..... 5-3

5.3.3 Allan Richards, Wadsworth Square Neighborhood Association 5-4

5.4 Written Comments Received via Mail Following the Public Hearing 5-5

5.4.1 John Glassman..... 5-5

5.4.2 James Cerniglia..... 5-6

5.4.3 Roger Brown, Rochester Regional Community Design Center 5-6

5.4.4 RRDCD Inner Loop Design Alternatives 5-7

5.4.5 Jeff Speck, Speck & Associates, LLC 5-9

5.4.6 Dawn Williams-Fuller, Ambassador Union Street, LLC..... 5-12

Appendices	
VOLUME 1	
A.	Maps, Plans, Profiles & Typical Sections
B.	Project Costs
C.	NEPA Checklist
D.	SEQR Documentation
E.	Non-Standard Feature Justification Forms
VOLUME 2	
F.	Go / No Go Analysis
G.	Traffic Analysis
H.	Accident Analysis
VOLUME 3	
I.	Visual Impact Assessment
J.	Hazardous Waste / Contaminated Material Screening
K.	Air Analysis
L.	Noise Analysis
M.	Smart Growth Screening Tool
VOLUME 4	
N.	Public Involvement
O.	Correspondence
P.	Memorandum of Agreement (Historic Resources)

CHAPTER 1 - EXECUTIVE SUMMARY

1.1. Introduction

This report was prepared in accordance with the NYSDOT Project Development Manual, 17 NYCRR (New York Codes, Rules and Regulations) Part 15, and 23 CFR (Code of Federal Regulations) 771. Project needs have been identified (section 1.2.2), objectives established (1.2.3) to address the needs, and cost-effective alternatives developed (1.3). This project is federally funded.

1.2. Purpose and Need

1.2.1. Where is the Project Located?

The project is located along the south eastern portion of the Inner Loop expressway within the City of Rochester, Monroe County, New York. The project limits include the following:

Inner Loop – South Clinton Avenue to East Main Street
Pitkin Street – Chestnut Avenue to East Main Street
Union Street – Monroe Avenue to East Main Street

See Figures 1.2.1.A, 1.2.1.B and 1.2.1.C for specific project location maps.

State Location Map

(See Figure 1.2.1.A)

Monroe County Map

(See Figure 1.2.1.B)

Project Location Map

(See Figure 1.2.1.C)



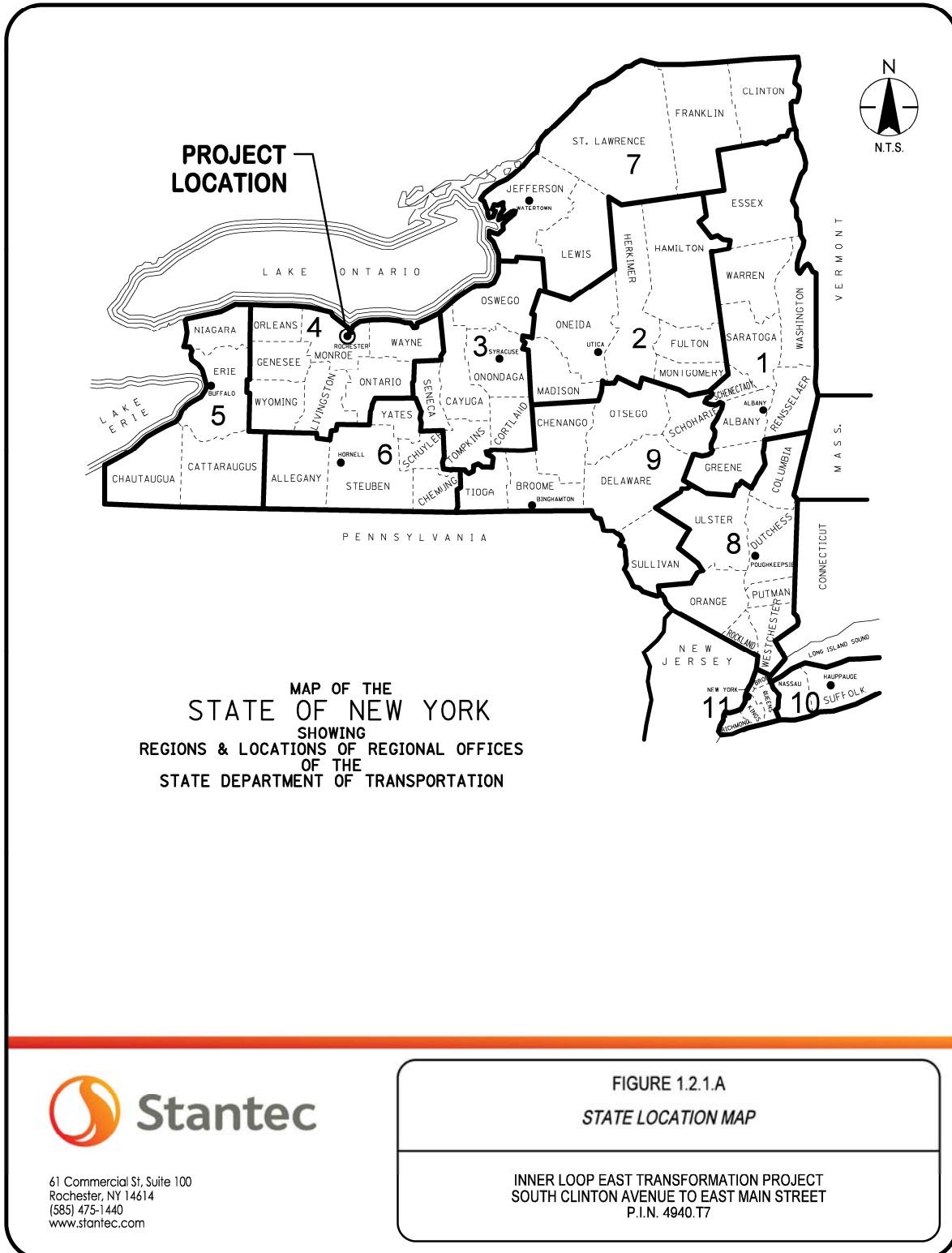

61 Commercial St, Suite 100
Rochester, NY 14614
(585) 475-1440
www.stantec.com

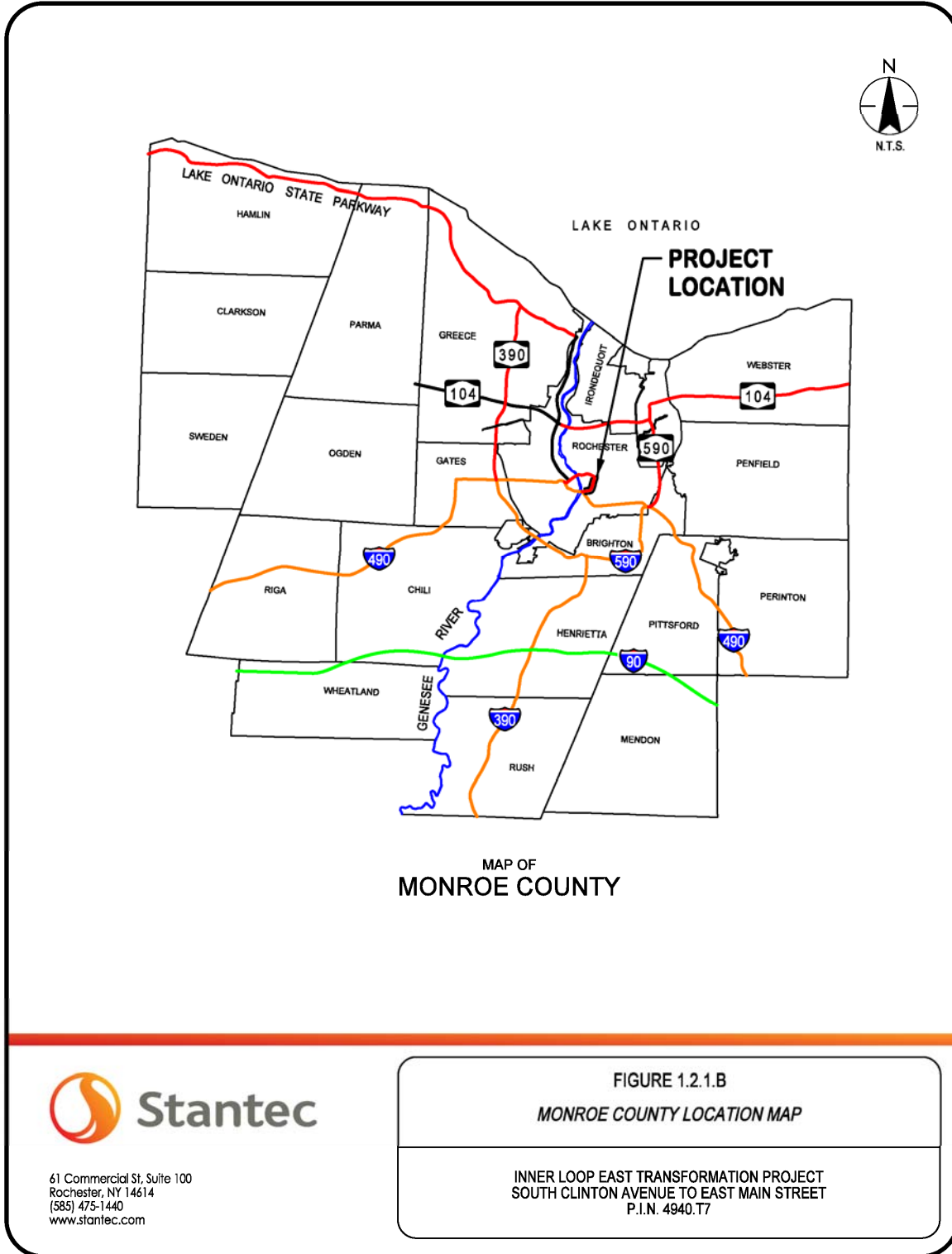

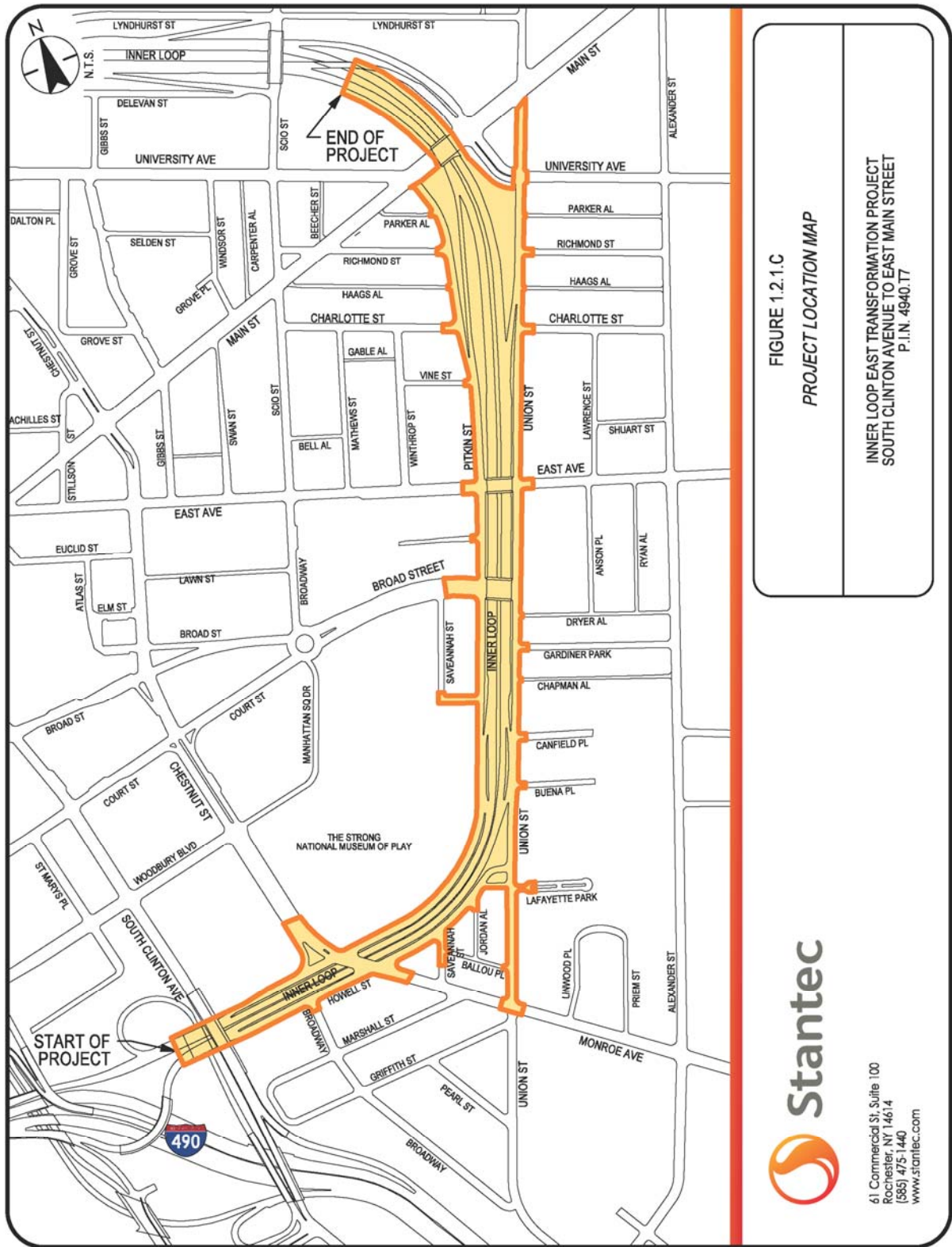

1.2.2. Why is the Project Needed?

Over the last 19 years, the City of Rochester has completed various initiatives focused on rejuvenating the Center City and the surrounding neighborhoods, thus providing for future economic opportunities in order to be able to compete in the global marketplace.

With the existing Inner Loop facility reaching 50 years of service, it is now time to evaluate major rehabilitation/reconstruction options for the future, while considering the facility's context within this important urban setting. To accomplish this, the City has reviewed options to redevelop the corridor, rebuild the neighborhood connections, encourage economic redevelopment in the vacated lands by the expressway, and encourage a more sustainable/ multi-modal transportation system.



Aging features include; bridge railings, light poles, signals, sign structures, guiderail, bridges, and retaining walls.

1.2.3. What are the Objectives/Purposes of the Project?

With the need to address deficiencies and inadequacies associated with this aging 50-year old transportation infrastructure corridor, the project objectives focus on the City's new vision for the southeast segment of the Inner Loop and specifically, the Center City redevelopment efforts, the current/future traffic demand, and community needs. The Inner Loop East Transformation Project is about capturing the opportunity to reconnect neighborhoods, spur economic development and provide an appropriate-scaled complete city street; by eliminating an underutilized grade separated access controlled expressway facility.

Based on the needs identified above, the following project goals and objectives have been established:

(1) Support or Enhance Community Quality of Life

- a. *Enhance local connectivity between Center City and adjacent neighborhoods.*
- b. *Reconnect the street grid system by breaking superblocks.*
- c. *Improve the visual built environment through context sensitive design that contributes to roadside/street ambiance, community character and public safety.*
- d. *Encourage sustainable land use patterns that are consistent with historic districts and community needs.*

(2) Enhance Economic Opportunities

- a. *Maintain or improve economic opportunities by addressing multi modal access.*
- b. *Create opportunity for new and infill development consistent with community plans.*
- c. *Support local community land use plans.*

(3) Enhance the Center City's Transportation Network

- a. *Improve connectivity between Center City and adjacent neighborhoods by reconnecting the street grid system.*
- b. *Promote alternative modes of transportation (Complete Street).*
- c. *Improve geometric design through the application of appropriate design standards to minimize or eliminate non-standard elements and/or geometries.*
- d. *Maintain peak period mobility.*
- e. *Eliminate structural deficiencies using treatment strategies that provide the lowest life cycle maintenance cost or minimize future major investment in reconstruction.*

(4) Preserve or Enhance Environmental Health

- a. *Minimize or maintain air quality and noise impacts on adjacent neighborhoods.*
- b. *Minimize impacts on designated community landmarks and historic resources.*
- c. *Minimize storm water impacts.*
- d. *Support local, regional and state environmental initiatives.*

1.3. What Alternative(s) Are Being Considered?

The feasible options at this time are to either reconstruct/rehabilitate or remove the expressway. The reconstruction alternative will be considered the traditional "no-build" scenario and will primarily include maintenance and rehabilitation of the existing highway, as needed.

No-Build (Null) Alternative: Maintain/Rehabilitate Existing Expressway - Under this alternative, the basic infrastructure would be retained and maintenance and rehabilitation efforts would be performed by primarily the State, along with City forces, to extend the service life of the existing infrastructure per the maintenance responsibilities of each agency.

Alternative 1: Removal of the Inner Loop – This alternative would remove the expressway infrastructure from Clinton Avenue to Richmond Street and fill-in the area to match the existing elevations of the adjoining frontage roads. The frontage road of Pitkin Street would be removed except a portion between East Avenue and Charlotte Street that would be reconstructed as a one-way local street to maintain access to the adjoining parcels. The frontage road of Union Street would be reconstructed as a two-way urban arterial street. The project would eliminate the bridges at Monroe Avenue, Broad Street, and East Avenue as well as the extensive retaining walls along both sides of the Inner Loop.

For a more in-depth discussion of the design criteria and nonstandard features see Section 3.2.1. Description of the Feasible Alternatives.

1.4 How will the Alternative(s) Affect the Environment?

Exhibit 1.4-A Environmental Summary			
NEPA Classification	Class II (Categorical Exclusion with Documentation)	BY	Federal Highway Administration (FHWA)
SEQR Type	Type I	BY	City of Rochester

Exhibit 1.4-B Comparison of Alternatives		
Category	Alternatives	
	Null	1
Wetland impacts	None	None
100 year floodplain impact	None	None
Archeological Sites Impacted	None	1 Site ⁽¹⁾
Architectural Sites Impacted	None	None
Noise Impacts	None ⁽²⁾	None ⁽²⁾
Air Impacts	None	None ⁽³⁾
Property impacts	None	7 parcels requiring Temporary Easements or Permanent Easements

Notes:

1. The project has an "Adverse Effect" on the Amos Burrows Site. See Section 4.4.11 for further information.
2. A noise Analysis was conducted for the project. Existing noise levels approach or exceed thresholds. Noise Levels for Alternative 1 were within 1 DBA of the null alternative. See Section 4.4.17 for further information.
3. An air Analysis was conducted for the project. Although some pollutants increase they do not exceed regulated thresholds. See Section 4.4.15 for further information.

Refer to Chapter 4 for further information.

Anticipated Permits/Certifications/Coordination:

Permits

NYSDEC

- None required

NYSDOT

- Highway Work Permit (Perm 33)

NYSDOH

- Application for Public Water Supply Improvement (DOH 348)
- Application for Sanitary Facilities (SAN 65) and (SAN 72)

Coordination

- Coordination with Federal Highway Administration (FHWA)
- Coordination with New York State Department of Transportation (NYSDOT)
- Coordination with New York State Historic Preservation Officer (SHPO)
- Coordination with Monroe County Department of Transportation (MCDOT)
- Coordination with Monroe County Division of Pure Waters
- Coordination with Genesee Transportation Council (GTC)
- Coordination with Rochester Genesee Regional Transit Authority (RGRTA)
- Coordination with Rochester City School District (RCSD)
- Coordination with Rochester City Police Department (RPD)
- Coordination with Rochester City Fire Department (RFD)
- Coordination with Public and Private Utilities
- Coordination with Rochester Regional Community Design Center (RRCDC)
- Coordination with Rochester Cycling Alliance (RCA)
- Coordination with Rochester Downtown Development Corporation (RDDC)
- Coordination with Business and Neighborhood Groups

Others

- Local Permits (as Required)

1.5. What Are The Costs & Schedules?

The Inner Loop Transformation Project will be funded through the Transportation Investment Generating Economic Recovery (TIGER) program with a 75% federal share and a 25% local share.

Design Approval is anticipated in March 2014 with construction beginning in October of 2014.

Exhibit 1.5A Project Schedule	
Activity	Date Occurred/Tentative
Design Approval	March 2014
ROW Acquisition	May 2014
Construction Start	October 2014
Construction Complete	November 2017

Exhibit 1.5B Comparison of Alternatives Project Costs (Millions)		
Project Costs	Alternative	
	Null	Alternative 1
Construction	\$0	\$22.085
ROW Costs	\$0	\$0.015
Total Construction Costs	\$0	\$22.100

1.6. Which Alternative is Preferred?

The feasible and prudent alternative that best meets the project objectives is Alternative 1. See Section 3.2.1 for a description of this alternative.

1.7. What are the Opportunities for Public Involvement?

Since 2001, when the City began considering the merits of redesigning the expressway into a properly-scaled urban arterial corridor, the City of Rochester has solicited public input. The following summarizes the City's Public Involvement Program for this project.

Inner Loop Improvement Study (2000 to 2001): This phase included a Technical Advisory Committee (numerous meetings), a Citizens Advisory Committee (numerous meetings), and a series of information meetings (June 22, 2000 and November 13, 2000).

Scoping Phase (2008-2013): Various meetings were held with the Technical Advisory Committee, as listed below. The Technical Advisory Committee included representatives from the City of Rochester, New York State Department of Transportation, Monroe County Department of Transportation, and Genesee Transportation Council. In addition, a public information meeting was also held in order to disseminate project-related information as well as solicit public input and comments. In the fall of 2012, the City also initiated a project web site to enhance the project's communication efforts with the Public.

- Technical Advisory Committee Meeting, October 15, 2008
- Technical Advisory Committee Meeting, January 22, 2009
- Technical Advisory Committee Meeting, March 5, 2009
- Technical Advisory Committee Meeting, December 8, 2009
- Technical Advisory Committee Meeting, August 22, 2013
- Public Information Meeting, August 28, 2013

Preliminary Design Phase (2013 - current): The City continues to engage the public in the overall development phases for this project.

- Public Open House, November 6, 2013
- Public Information / Hearing, February 4, 2014

Questions should be directed to (please include the six digit Project Identification Number_(PIN) 4940.T7):

Paul Way, P.E., Project Manager

Email: Paul.Way@CityofRochester.gov
Telephone: (585) 428-7383

Mailing Address
City of Rochester
DES/Architecture & Engineering
City Hall, 30 Church Street, Room 300B
Rochester, New York 14614-1279

You can visit the Project's website: <http://www.cityofrochester.gov/InnerLoopEast/>

The remainder of this report is a detailed technical evaluation of the existing conditions, the proposed alternatives, the impacts of the alternatives, copies of technical reports and plans, and other supporting information.

CHAPTER 2 - PROJECT CONTEXT: HISTORY, TRANSPORTATION PLANS, CONDITIONS AND NEEDS

This chapter addresses the history and existing context of the project site, including the existing conditions, deficiencies, and needs for this part of the Rochester Inner Loop corridor.

2.1. Project History

With the vehicle population explosion in and around the City of Rochester in the 1930's and 1940's, the New York State Department of Transportation and the City of Rochester developed plans in the late 1940's for a network of boulevards and expressways designed to reduce traffic congestion on the local city streets and improve access around the center city. The idea for a beltway around Rochester was conceived in the 1950s. At that time, the population of Rochester was roughly 332,000, which translated into poor traffic conditions within downtown. Construction on the highway therefore began in the early 1950s. Many structures were razed to make way for the route, which was constructed through densely populated neighborhoods that surrounded downtown. In 1965, the Inner Loop expressway was officially opened to traffic.

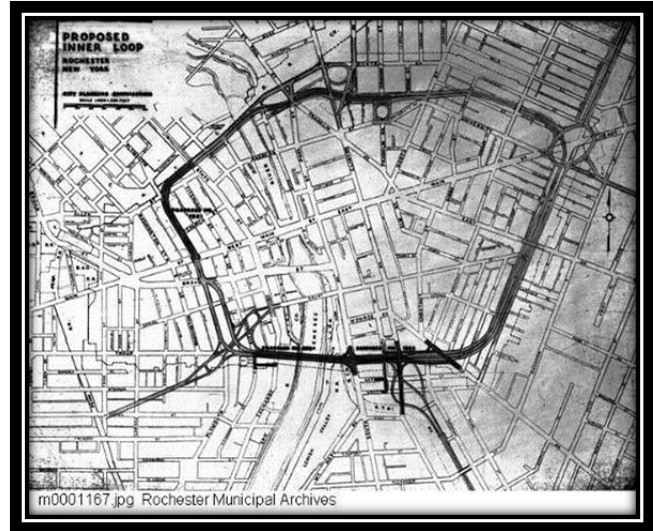

Historical Plan of the Inner Loop

In the time since the Loop's construction, the population of Rochester has dropped to 210,565, as of the 2010 census, a reduction of more than one-third. Over the past decade, traffic volume has remained constant on the roadway in some areas; however, overall usage from its completion to today has declined as jobs and residents continue to migrate away from the inner city. The original Inner Loop has accomplished its purpose.

More recently, the southeast section of the Inner Loop between Monroe Avenue and East Main Street has been identified as a viable candidate for removal. The southeast section of the Inner Loop is a four to six lane divided expressway with parallel two to three lane one-way frontage roads (Union and Pitkin Streets). The frontage roads and the Inner Loop are connected with entrance and exit slip ramps located at service points in the system. This results in a facility that in some places has as many as twelve travel lanes and occupies a width ranging from 182 feet to 355 feet (frontage road outside curb to frontage road outside curb). This section serves approximately 6,990 vehicles per day. Those volumes could be served by a lesser facility such as a community-scale urban arterial, which is more in context with the neighborhood and prior plans that call for the "right-sizing" of city streets.

Over the last 19 years, the City of Rochester has completed various initiatives focused on revitalizing the Center City and the surrounding neighborhoods in order to rejuvenate districts, thus providing for future economic opportunities in order to be able to compete in the global marketplace. These City initiatives have included:

- *The Vision 2000 Plan*
- *The Neighbors Building Neighborhoods Program*
- *City of Rochester's Inner Loop Improvement Study, 2001*
- *Center City Master Plan, 2003*

- *Rochester Regional Community Design Center – Charrette – A Community Based Vision Plan for Downtown Rochester, 2007*
- *The Renaissance 2010 Comprehensive Plan*
- *GTC Long Range Transportation Plan*
- *Project Scoping Report, 2013*

The 2001 Rochester Inner Loop Improvement Study assessed the existing configuration of the Inner Loop and ultimately made recommendations for modifications. The 2001 Inner Loop study looked at a broader study area that included the eastern section, from the I-490 interchange on the south, to the North Clinton Avenue interchange on the north side of the Central Business District. The 2001 Inner Loop initial study area was broken into three segments covering the northeast section from East Main Street to North Clinton Avenue, the southeast section from Monroe Avenue/Chestnut Street to East Main Street, and the I-490/Inner Loop interchange. Numerous conceptual alternatives were developed at that time along with an implementation program that recommended that the Inner Loop from Monroe Avenue to East Main Street be eliminated as the first phase.

Since then, the 2003 Center City Master Plan and the 2007 Downtown Charrette Report evaluated the challenges and opportunities associated with the possible removal or transformation of the Inner Loop in the southeast quadrant. Both studies focused on creating a plan for the downtown area including the evaluation of needs for each of the neighborhood districts. The 2007 Downtown Charrette Report identifies the need to connect distinctive districts and neighborhoods in Downtown. The Southeast Loop area occupies some of the most valuable real estate in Center City. Within the southeast area, connecting the East End (west side of Inner Loop from Main Street to Broad Street), Upper East End (east side of Inner Loop from University to north of Howell) and the Manhattan Square (west side of Inner Loop from Broad Street to Monroe Ave) districts is essential, and removing the southeast section of the Inner Loop will make it possible.

In each of these efforts, there was a reoccurring theme that identified the Inner Loop as one of the focus areas for the City of Rochester. The energy and momentum surrounding the City's revitalization and the desire to reconnect various districts and neighboring communities provided the catalyst for this Inner Loop study. Therefore, the transformation of the Inner Loop project is consistent with the local master plan goals and objectives for this area.

2.2. Transportation Plans and Land Use

2.2.1. Local Plans for the Project Area

2.2.1.1. Local Comprehensive Plans (“Master Plan”) -

The Long Range Transportation Plan for the Genesee-Finger Lakes Region 2035 identifies the direction for the region's transportation system and serves as the framework for future investment in highways, bridges, public transportation, bicycle and pedestrian paths and trails, and transportation-related air quality improvement projects. One of the illustrative projects (*Projects that represent actions above and beyond those that can reasonably be expected to be accomplished given limited federal resources*) in the plan calls for the reconstruction of the southeast portion of the Inner Loop as an at-grade boulevard based on a strong interest in continuing the revitalization of Downtown Rochester. As envisioned, the reconstruction would reclaim land for private, taxable development, and improve connections between Downtown Rochester and surrounding neighborhoods. The reconstructed facility would allow for bicycling and walking, and ultimately improve the overall neighborhood cohesion.

The Regional Planning Group has reviewed the local comprehensive plan prepared for the Genesee-Finger Lakes Region that includes the City of Rochester. This project is consistent with the local comprehensive plan.

2.2.1.2. Local Private Development Plans –

There are various public developments planned near the project area that will impact travel patterns and operations. Below is a listing of projects that will require coordination during final design:

- Center City Two-Way Conversion Project (2016)
- Inner Loop Bridge over the Genesee River (2014)
- Bridge Painting I-490 (2014)

2.2.2. Transportation Corridor

2.2.2.1. Importance of the Project Route Segment -

The Inner Loop was originally planned, designed and constructed as part of a network of boulevards and expressways designed to reduce traffic congestion on the local city streets and improve access around the center city. The existing corridor (South Clinton Avenue to East Main Street) is underutilized for the infrastructure present (10 to 12 travel lanes). In the project study area, the frontage roads of Pitkin and Union Street combined carry a similar volume of traffic as the Inner Loop.

2.2.2.2. Alternate Routes –

The frontage roads of Pitkin and Union Street would be suitable as a permanent replacement for the southeast section of the Inner Loop. A regional traffic model was developed and evaluated by GTC, NYSDOT, MCDOT and the City of Rochester to determine the impacts the removal of the expressway system would have on area traffic. The results concluded that although traffic volumes would increase on Union Street, the remaining expressway network (Inner Loop, I-490, I-390 and I-590) and surrounding arterial network would not be impacted. A copy of the results is included in Appendix F.

2.2.2.3. Corridor Deficiencies and Needs -

The following provides an overview of the project needs. These are a summary of the information contained within this document, which assesses the existing and future conditions.

Community Cohesion: Past public input, through various City community initiatives, has identified significant challenges surrounding the southeast section of the Inner Loop expressway, primarily related to livability and accessibility. These challenges include: overcoming the barrier effect, right-sizing the streets, breaking up the superblocks, and maximizing development potential. A seamless connection to the greater downtown and the southeast neighborhoods centered on Monroe, East and University Avenues is desired. Creating gateways to these districts, creating civic space and new/infill development to reconnect various neighborhoods has been identified. Streets need to be 'right-sized' and reconceived as a complete environment for pedestrians, bicyclists, and transit users as well as private vehicles.

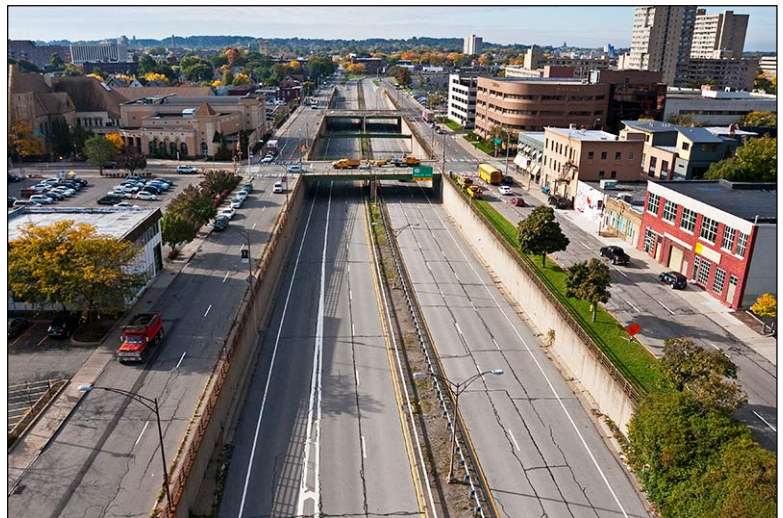

The vastly underutilized Inner Loop expressway is a significant barrier for motorists, pedestrians, bicyclists and community cohesion.

Economic Redevelopment: The southeast loop area occupies some of the most valuable real estate in Center City and optimal use needs to be considered. The city has completed various initiatives focused on revitalizing the Center City and the surrounding neighborhoods (East End, Upper East End, and Manhattan Square). The City is committed to rejuvenating the City by providing future economic development opportunities that will allow the region to compete in the global marketplace.

Capacity: The overall expressway system is operating significantly under capacity with traffic volumes better reflecting arterial levels. There is similar traffic on the combined adjacent service roads (Union and Pitkin Streets) as the southeast section of the Inner Loop.

Highway Design: When the Inner Loop was constructed in the 1960s, highway design standards were different from today. The primary study corridor geometrics represent areas where deficiencies (non-standard and non-conforming features) are evident between past and present design standards. Inner Loop non-standard design features include: horizontal curvature, super elevation, sight distance and road widths (shoulders, medians and clearances). Non-conforming features include the layout of the existing slip ramps, which provide ingress and egress to the Inner Loop.

Structural Issues: There are four major bridges (Monroe Avenue, Broad Street, East Avenue, and East Main Street) within the project limits. The Monroe Avenue, East Avenue, Broad Street and East Main Street bridges will require future investment to repair current deficiencies.

Safety: The southeast section of the Inner Loop expressway is not shown to have safety concerns due to limited traffic volumes. Accident rates are below the statewide average for similar interstate systems. There are safety concern areas on the local system such as along the Union Street corridor (e.g. East Avenue and Broad Street intersections), with safety concerns attributable to sight distance restrictions from adjacent buildings and bridge railings over the Inner Loop.

2.2.2.4. Transportation Plans -

This project is on the region's Transportation Improvement Program (TIP) as project number H01-05-MN1, the Statewide Transportation Improvement Program (STIP) as PIN 4940.T7, and on the Genesee Transportation Council's Long Range Transportation 2035 plan as one of just five illustrative projects. Funding sources have been allocated to complete the preliminary and final engineering. Federal FY2013 TIGER Discretionary Grant funds to finance the construction phase have been identified and secured.

2.2.2.5. Abutting Highway Segments and Future Plans for Abutting Highway Segments -

The abutting highway segments include South Union Street and Pitkin Street. South Union Street is a three lane, one-way northbound street on the east side of the Inner Loop with on-street parking. South Union Street functions as a frontage road to the Inner Loop with various on-off ramps. Pitkin Street is a 2-3 lane southbound one-way city street along the west side of the Inner Loop with on-street parking. Pitkin Street also functions as a frontage road to the Inner Loop with various on-off ramps. Both abutting road segments provide access to other city streets and properties. No current plans exist for either of these streets at this time.

There are no plans to reconstruct or widen highway segments within the project corridor, or the adjoining segments, within the next 20 years.

2.3. Transportation Conditions, Deficiencies and Engineering Considerations

2.3.1. Operations (Traffic and Safety) & Maintenance

2.3.1.1. Functional Classification and National Highway System (NHS) –

Figure 2.3.1.1 shows the Functional Classification and National Highway System classifications for the Inner Loop expressway and surrounding roadway network. The Inner Loop is classified as a Principal Arterial Expressway on the National Highway System. I-490 is classified as an Interstate expressway. All other adjacent roadways included in the study area are classified as Minor Arterials; with the exception of Pitkin Street which is classified as a local city street.

Figure 2.3.1.1 - Functional Classification

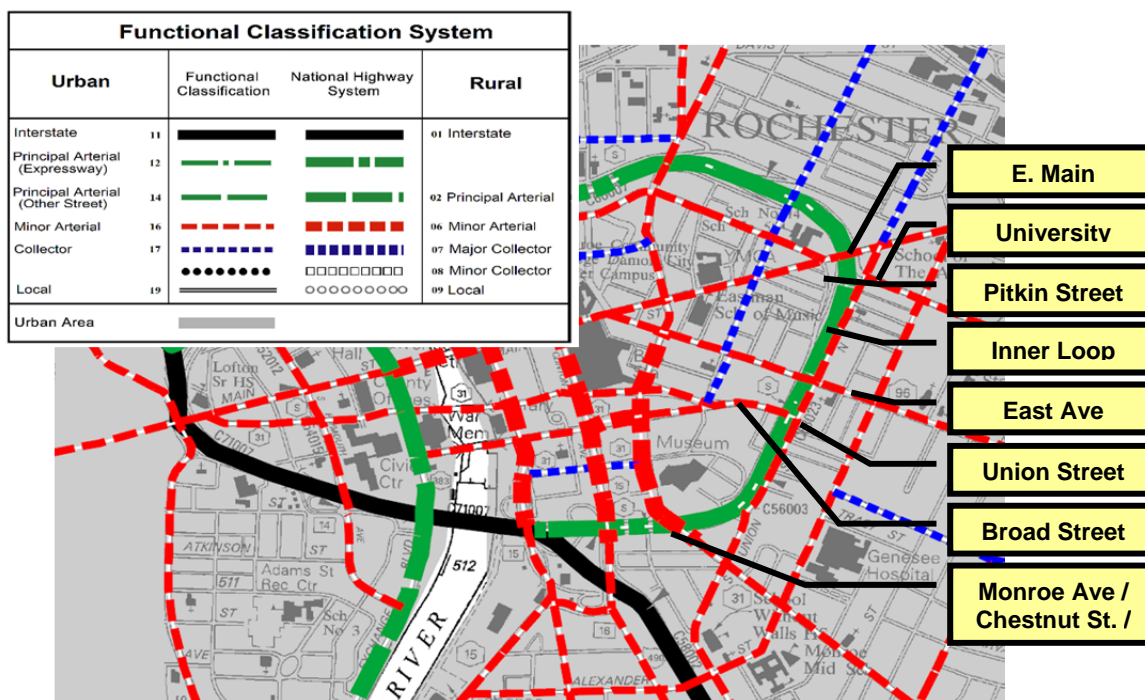

Source: NYSDOT, Region 4, 2000 Urban Functional Classification Map, Rochester Urban

Exhibit - 2.3.1.1 Classification Data			
Route(s)	Inner Loop (NY 940T)	Union Street	Pitkin Street
Functional Classification	Urban Principal Arterial Expressway	Urban Minor Arterial	Urban Local
National Highway System (NHS)	Yes	No	No
Designated Truck Access Route	Yes	No	No
Qualifying Highway	Yes	No	No
Within 1 mile of a Qualifying Highway	NA	Yes	Yes
Within the 16' vertical clearance network	No	No	No

National Network of Qualifying Highways – I-490 & NY 940T
 Qualifying and Access highways – I-490 & NY 940 T

2.3.1.2. Control of Access -

Access is fully controlled on the Inner Loop expressway, with slip ramps from both frontage roads (Union and Pitkin Streets) providing points of ingress/egress for motorists. Access is uncontrolled on Union and Pitkin Streets, as well as the intersecting roadways such as East Main Street, University Avenue, East Avenue, Broad Street and Monroe Avenue.

2.3.1.3. Traffic Control Devices –

The Inner Loop is a free-flowing urban expressway with no traffic signals; stop sign control devices or ramp metering. The following adjacent intersections are controlled by traffic signals:

Intersection	Signalization	Comments
E. Main/University/Pitkin	diamond interchange with an extra road in the middle (Inner Loop/University connector).	
E. Main/Inner Loop/University		
E. Main/Union		
Union/University	One Controller	
East Avenue/Pitkin	One controller, uses standard diamond interchange operation.	
East Avenue/Union		
Broad Street/Pitkin	One controller, uses standard diamond interchange operation.	
Broad Street/Union		
Monroe/Pitkin	One controller, uses standard diamond interchange operation.	Street name changes to Chestnut Street on the north leg of the interchange.
Monroe/Howell		
Monroe/Union	One Controller	

Other entrances/exits to/from the Inner Loop are yield/stop controlled.

Most of the traffic control devices, such as sign structures, signals and traffic signs are nearing the end of their design life and are in need of replacement.

2.3.1.4. Intelligent Transportation Systems (ITS) –

MCDOT Operates traffic cameras at the following intersections that offer views of the project corridor:

- E. Main Street @ University / Pitkin
- Monroe Ave. @ S. Union Street
- East Ave. @ Alexander Ave. (outside project limits)
- Broad Street @ Chestnut (outside project limit)

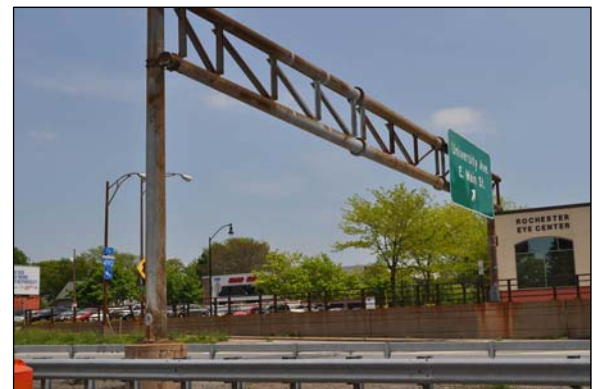

Aging Sign Structures and Traffic Signs in need of replacement

NYS DOT Operates traffic cameras at the following locations that offer views of the project corridor:

- I-490 Bridge over the Genesee River

To provide coverage of the corridor, MCDOT has requested that additional cameras be installed at the following locations:

- S. Union Street @ Broad Street or S. Union Street @ East Ave
- Monroe Ave. / Chestnut @ Howell Street

2.3.1.5. Speeds and Delay –

A speed and delay study was not conducted specifically for this project; however a “Travel Time Data Collection Program” report was conducted by the Genesee Transportation Council in October 2008. Speed and travel time data was collected for the entire length of the Inner Loop from I-490 to I-490 during the morning, mid-day and evening peak hours. The average speeds and travel times are summarized in the table below. There is no delay, associated with traffic congestion within the corridor, in the morning, mid-day or evening peak hours.

Exhibit - 2.3.1.5 (A) Speed Data		
Route	Inner Loop	All City Streets
Existing Speed Limit	45 MPH	30 MPH

Exhibit - 2.3.1.5 (B) Speed Data – Operating Speed per Data Collection Program							
Inner Loop Direction	Distance	Mid-Day (Free Flow)		Morning Peak Hour		Evening Peak Hour	
		Speed (MPH)	Travel Time (min)	Speed (MPH)	Travel Time (min)	Speed (MPH)	Travel Time (min)
NB	2.6 miles	50.2	3.1	50.8	3.1	46.6	3.4
SB	2.8 miles	48.4	3.6	49.1	3.6	47.1	3.4

2.3.1.6. Traffic Volumes –

In 2008 traffic turning movement counts were obtained during the weekday morning and evening peak travel hours along the project section of the Inner Loop and adjacent intersections. Heavy vehicle (truck and bus) data was also obtained at each of the intersections and reflected in the analysis.

The Genesee Transportation Council’s Regional Travel Demand Model for the years 2005 to 2014 reflects all the planned land use changes in and around the Rochester Central Business District (CBD). While change in traffic between 2005 and 2014 varies depending on what roadway section was reviewed, at most it shows a maximum increase of 10% over that period. Traffic growth along most roadway sections however is less than 5% (or 0.625% per year) during the forecasted 8 year period. Thus, to determine Inner Loop traffic at ETC+20 or for 2035, the following steps were taken:

- **2008 Existing Traffic** – current counts were used.
- **2015 (ETC)** – the MCDOT’s future (2015) Synchro traffic files that reflect land use changes (i.e., Midtown, Chestnut/Broad Street projects and other residential /commercial) proposed in the CBD were used.
- **2035 (ETC+20) No-Build Traffic** - 2015 forecasted traffic was increased by 0.625% per year using a straight line percent increase.

This method of forecasting future travel for the project was presented, reviewed and accepted by NYSDOT, MCDOT, GTC and the City of Rochester.

2.3.1.6. (1) Existing traffic volumes –

Refer to Exhibits 2.3.1.6-1 for a summary of the traffic data. A discussion of the traffic count methodology, peak hour, and turning movement volumes for intersections with identified accident problems, all major intersections, & major traffic generator driveways/entrances are included in Appendix G.

Exhibit - 2.3.1.6-1 Existing and Forecast Traffic Volumes												
Route	Inner Loop Expressway				Union Street				Pitkin Street			
	Monroe Ave. To Broad St.		East Main St. to Scio St.		Monroe Ave. to Howell St.		East Ave. to University Ave.		Monroe Ave. to Broad Street		Charlotte St. to East Main St.	
Year	ADT	DHV	ADT	DHV	ADT	DHV	ADT	DHV	ADT	DHV	ADT	DHV
Existing (2008)	6,990	600	10,560	690	4,400	440	5,250	525	2,400	240	2,050	205
ETC (2015)	6,990	600	10,560	710	4,400	440	5,600	560	2,400	240	2,050	205
ETC+20 (2035)	7,920	680	11,935	800	4,900	490	6,350	635	2,700	270	2,300	235

Note: ETC is the Estimated Time of Completion

2.3.1.6. (2) Future no-build design year traffic volume forecasts –

The Estimated Time of Completion (ETC) +20 design year was selected per PDM Appendix 5. An ETC+30 year projection was not completed as the project is not near a bridge or large culvert. Peak hour turning movement volumes for intersections with identified accident problems, all major intersections, & major traffic generator driveways/entrances are included for the design year(s) in Appendix G.

2.3.1.7. Level of Service and Mobility -

2.3.1.7. (1) Existing level of service and capacity analysis –

The Highway Capacity Manual (HCM 2000) and the Synchro7 software were used to determine Level of Service (LOS) for current operating conditions. The analysis found that the Level of Service on all roadway segments of the Inner Loop and adjacent intersections are operating well; all with Level of Service (LOS) of “C” or better with no individual turning movements below LOS “D”.

2.3.1.7. (2) Future no-build design year level of service –

Future conditions at the estimated time of completion (ETC) and at ETC+20 for the null or no-build year will continue to deteriorate. Capacity analysis indicates that overall intersections will remain at good levels, Level “C” or better; however, various movements at certain intersections will start to degrade to Level “E” or below. Taking a closer look at these locations, higher volume to capacity ratios and queuing are also noted. These lower levels of operation are primarily concentrated at the Juncture of East Main Street/ University/ Union Street/ Inner Loop ramp area. Exhibit 2.3.1.7-1 provides a summary of the Level of Service results for Existing Conditions, ETC and ETC+20.

Exhibit - 2.3.1.7-1 Intersection Level of Service (Null Alternative)							
Intersection	Approach & Movement	Existing Conditions (2008)		Estimated Time of Completion (ETC) (2015)		ETC+20 (2035)	
		AM	PM	AM	PM	AM	PM
Monroe Avenue & Inner Loop EB Ramps	NB THRU/RT	A	A	B	B	B	B
	SB LT/THRU	A	A	A	A	A	A
	EB THRU/LT	D	D	D	D	D	D
	EB RT	B	B	A	B	A	B
	OVERALL	B	A	B	A	B	A
Monroe Avenue & Inner Loop WB Ramps	NB LT	A	A	A	A	A	A
	NB THRU/RT	B	A	B	A	B	B
	SB THRU	B	A	B	A	B	A
	WB THRU/RT	C	D	C	D	C	D
	OVERALL	B	A	B	A	B	A
Monroe Avenue & South Union Street	NE LT	B	D	B	D	C	D
	NE THRU	B	D	B	D	C	D
	SE LT	A	A	A	A	A	A
	SE THRU	B	A	B	A	B	A
	NW THRU	A	A	B	A	B	A
	NW RT	A	A	A	A	A	A
	OVERALL	B	B	B	B	B	B
South Union Street & Broad Street	NB LT	D	D	D	D	D	D
	NB THRU	C	C	C	C	C	C
	EB LT	A	A	A	A	A	A
	OVERALL	C	C	C	B	C	B
Pitkin Street & Broad Street	SB LT/THRU	B	D	B	C	B	C
	EB THRU	A	A	A	A	A	A
	EB RT	A	A	A	A	A	A
	WB LT/THRU	A	A	A	A	A	A
	OVERALL	A	B	A	B	A	B
South Union Street & East Avenue	NB THRU/LT	C	D	C	D	C	D
	NB RT	B	B	B	B	B	B
	EB THRU	A	A	A	A	A	A
	WB THRU	A	C	A	C	A	C
	OVERALL	A	B	A	B	A	B

Exhibit - 2.3.1.7-1 Intersection Level of Service (Null Alternative)							
Intersection	Approach & Movement	Existing Conditions (2008)		Estimated Time of Completion (ETC) (2015)		ETC+20 (2035)	
		AM	PM	AM	PM	AM	PM
Pitkin Street & East Avenue Pitkin Street & East Avenue (Continued)	SB LT	D	D	D	D	D	D
	SB THRU	D	C	D	C	D	C
	EB THRU	B	B	B	B	B	B
	EB RT	A	A	A	A	A	A
	WB THRU	A	A	A	A	A	A
	OVERALL	C	B	B	B	B	B
University Avenue & South Union Street	NB LT	C	C	C	C	C	C
	NB THRU/RT	B	C	B	C	B	C
	EB THRU	A	A	A	A	A	B
	WB LT/TH/RT	A	A	A	A	A	B
	OVERALL	A	B	A	B	A	B
East Main Street & Union Street	NB LT	D	D	D	D	D	D
	NB THRU/RT	C	C	C	C	C	D
	SB LT/RT	B	B	B	B	B	D
	EB LT	A	A	A	A	A	A
	EB THRU	A	A	A	A	A	A
	WB THRU	C	D	C	D	C	F
	OVERALL	B	C	B	C	B	D
East Main Street & Inner Loop Ramps	NB LT	D	D	D	D	D	D
	NB THRU	C	D	C	D	C	D
	SB LT	D	D	D	D	E	D
	SB THRU/RT	D	D	D	D	D	D
	EB LT	C	B	C	B	C	B
	EB THRU	C	B	C	B	C	C
	EB RT	A	A	A	A	A	A
	WB THRU	A	B	A	B	B	B
	WB RT	A	A	A	A	B	A
OVERALL	C	C	C	C	C	C	
East Main Street & University Avenue / Pitkin Street	SB LT	D	C	D	C	D	C
	SB THRU/RT	D	B	D	B	D	C
	EB LT	B	C	C	C	C	C
	EB THRU	C	C	C	C	C	C
	WB LT	A	A	A	A	A	A
	WB THRU	A	A	A	A	A	A
	WB RT	A	A	A	A	A	A
	OVERALL	B	B	B	B	B	B

2.3.1.8. Safety Considerations, Accident History and Analysis –

Accident information (39-month period between January 1, 2005 and March 7, 2008) was obtained for the section of the Inner Loop expressway from the Rt. 490 interchange to north of the East Main Street interchange. The accident history identified a total of 49 accidents occurred along the Inner Loop (mainline) in this area. The reportable accidents accounted for 30 (61%) of the total accidents and the non-reportable accidents accounted for 19 (39%) of the total accidents. The following list summarizes the types and number of reportable accidents. The rest of the assessment (analysis, rates and potential corrective action) will be related to the reportable accidents only that occurred in the corridor. Exhibit 2.3.1.8.A shows predominant accident types.

Exhibit - 2.3.1.8.A Collision Summary Inner Loop Expressway, From I-490 to East Main Street		
Type of Collision	Number	Percentage
Fixed Object	17	57
Sideswipe	5	17
Rear End	4	13
Right Angle	1	3
Head-On	1	3
Unknown/Other	2	7

The accident severity included 13 injuries (43%) and 17 (57%) property damage only. Fifty three percent of all accidents occurred during evening hours with 55% occurring on dry pavement conditions. Seventy percent of the vehicles involved were traveling in a westerly direction. As indicated above, 57% of the accidents involved collision with fixed objects (guide rail, curbing, abutment, debris). Only four of the 30 accidents occurred at a merge/diverge ramp location, with the majority of accidents occurring on the mainline along the horizontal curve between East Main Street and East Avenue. The accident rate for the corridor was calculated and compared to statewide accident rates for Principal Arterial expressways. The current accident rate is 2.48 accidents per million vehicle miles (acc/mvm), which is below the statewide average of 2.72 acc/mvm. Collision diagrams, detailed accident history, and rate calculations are provided in Appendix H.

An extended study area was also reviewed that included the following at grade adjacent corridors: East Main Street, Monroe Avenue/Chestnut, Pitkin Street, Union Street, and a portion of Interstate 490. Exhibit 2.3.1.8.B summarizes the number of reportable accidents and the calculated accident rates for the corridor and intersections for each of these adjacent roadways. Locations experiencing above state or county wide accident rates are in bold.

Appendix H includes a full detailed summary of the entire accident history within the extended study area.

Exhibit - 2.3.1.8.B – Accident Rates			
Intersection	Number of Accidents	State / County Rate	Actual Rate (ACC/MEV)
E. Main @ University/Pitkin	7	0.26 / 0.46	0.33
E. Main @ University/Inner Loop	40	0.26 / 0.46	0.96
E. Main @ N. Union Street	23	0.26 / 0.46	0.83
Pitkin @ East Ave.	8	0.34 / 0.22	0.44
Pitkin @ Broad	4	0.34 / 0.22	0.66
N. Union @ University	14	0.34 / 0.22	0.65

Exhibit - 2.3.1.8.B – Accident Rates			
Intersection	Number of Accidents	State / County Rate	Actual Rate (ACC/MEV)
Union @ East Ave.	17	0.34 / 0.22	1.13
S. Union @ Broad	3	0.19 / 0.22	0.71
Monroe @ Inner Loop / Pitkin	7	0.34 / 0.22	0.26
Monroe @ Inner Loop / Howell	5	0.34 / 0.22	0.34
Monroe @ S Union	20	0.34 / 0.22	1.12
Link Rate			
Inner Loop – I-490 to E Main	30	2.72	2.48

Pitkin Street corridor – 12 accidents occurred over a 32-month period. There were 5 (42%) rear-end accidents, 3 (25%) right angle, 1 (8%) right turn, 1 (8%) overtaking, 1 (8%), pedestrian, 1 (8%) unknown accident. One or 8% of the reportable accidents involved a personal injury, while the remainder of the accidents involved property damage only.

Union Street corridor – 61 accidents occurred over a 39-month period. There were 21 (34%) right angle, 12 (20%) rear-end, 10 (16%) left turn, 4 (6%) backing up, 3 (5%) sideswipe, 3 (5%) fixed object, 3 (5%) right turn, 3 (5%) unknown, 1 driveway and 1 overtaking accident. Ten accidents (16%) of the 61 reportable accidents involved personal injuries; the remainder were property damage only.

In summary, the Inner Loop expressway does not have safety concerns as there is relatively little traffic, although the rate of severe (personal injury type) is a relatively high percentage of the overall accidents reported. The expressway accident rate is below the statewide average for similar interstate systems. There are however some isolated safety concern areas on the local system such as along the Union Street corridor (e.g. East Avenue and Broad Street intersections) with safety concerns attributable to sight distance restrictions. The other intersections are also exhibiting rates over average rates, but the patterns are consistent with high volume low speed urban intersections.

An accident analysis was performed in accordance with the Highway Design Manual Chapter 5 in 2008. Although the accident analysis was performed in 2008, the Regional Traffic Engineer has concurred that the older data is still representative of current condition. The accident analysis included an accident summary (TE-213) and collision diagrams (TE-56).

2.3.1.9. Existing Police, Fire Protection and Ambulance Access -

No emergency service facilities are located within the project limits however; emergency vehicles routinely use the Inner Loop expressway and adjacent roadway system.

2.3.1.10. Parking Regulations and Parking Related Conditions –

Parking on Interstate highways is restricted by law within the project limits.

There are areas regulated by parking restrictions along the adjacent frontage roads including Pitkin Street and South Union Street. The area of South Union Street between Monroe Avenue and East Avenue experiences an extremely high demand for parking at all times of the day. This is attributed to several adjoining dead end streets and the predominately multi-family dwellings within this area. Parking within the area of East Avenue is also limited on Sundays due to the large congregation (3000+) of the Bethel Church.

2.3.1.11. Lighting –

There is street lighting along the Inner Loop expressway and adjacent city streets. The lighting systems are original to the Inner Loop installation and are in need of replacement. It is anticipated that street lighting will be replaced in conformance with the City of Rochester’s street lighting requirements.

2.3.1.12. Ownership and Maintenance Jurisdiction –

The original construction of the Inner loop was built with Federal Highway Administration funding. The property acquisition for the construction was equally funded by the City of Rochester and the New York State Department of Transportation.

In summary, the Inner Loop Expressway and I-490 are owned and maintained by the NYSDOT; the frontage roads and other local streets are owned and maintained by the City of Rochester. The bridges crossing the Inner Loop are shared by the NYSDOT and City of Rochester; with NYSDOT being responsible for the superstructure and substructure, and the City is responsible for the pavement, sidewalks and curbs. The lighting along the Inner Loop is currently a mix of County and City lighting (in general, it is County lighting on the mainline and ramps, and City lighting on the frontage roads). It should also be noted that Monroe County Department of Transportation maintains and operates all the traffic signals, regardless of ownership.



Deteriorated light poles are throughout the project corridor

2.3.2. Multimodal

2.3.2.1. Pedestrians –

Overall, the Inner Loop configuration (depressed highway) presents a significant east west barrier to pedestrian mobility within the study area.

Pedestrian access across the Inner Loop is limited from South Clinton Avenue to East Main Street (one mile). Suitable options for crossing the Inner Loop exist at the four roadway bridge crossings at Monroe Avenue, Broad Street, East Avenue and East Main Street. A major gap exists from Monroe Avenue to Broad Street (1/3 mile or 1,700 feet). Pedestrians have been frequently observed illegally crossing within this mid-segment.

Also, pedestrians are prohibited from using the Inner Loop by state law, since it is a limited access highway.



Pedestrians frequently cross the Inner Loop due to the barriers created by the expressway

Pedestrians are accommodated in the study area on the city streets, arterials, and the frontage roads.

2.3.2.2. Bicyclists –

The general configuration of the Inner Loop (depressed highway), the adjacent one-way frontage roads, and the limited east west connections, make bicycle mobility difficult within the study area.

Bicycles are strictly prohibited along the Inner Loop as a limited access highway by State Law, and therefore, there are no plans for a bicycle route within the Inner Loop expressway.

Also, there are no separate provisions for bicycles within the project limits. Bicycles are accommodated in the travel lane or on the shoulder area of adjacent streets.

The Genesee Transportation Council has recently published the 2009 Bike Map for the region. Major adjoining roads in the project area are classified as good or fair riding conditions. The map below shows Current bike ratings for the roadway network surrounding the project limits.

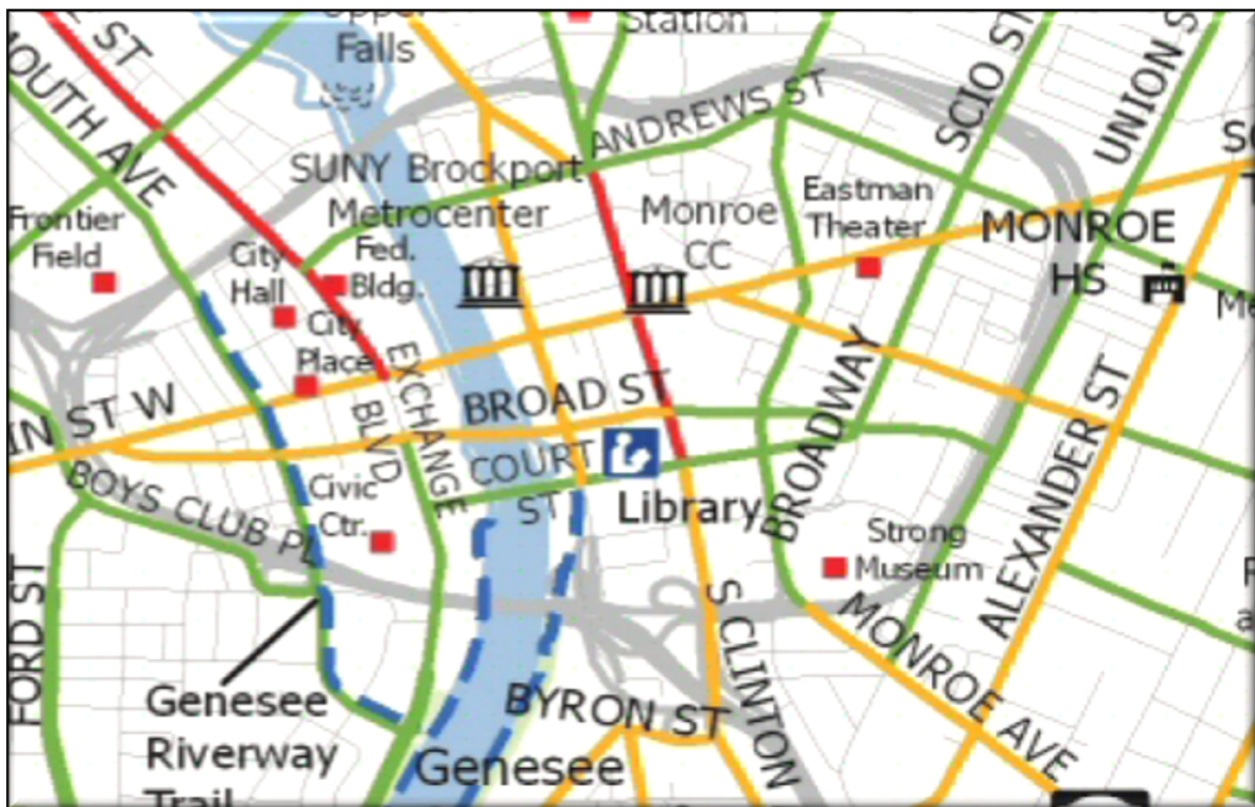

Source: Genesee Transportation Council 2009 Bike Map

2.3.2.3. Transit –

The Rochester Genesee Regional Transportation Authority (RGRTA) provides and operates transit services for the greater Monroe County area.

RGRTA's headquarters and bus garage are located along East Main Street east of the study area. Due to their proximity to the study area, a notable amount of bus traffic traverses the study roads on a daily basis; in addition there are various RTS routes that serve the immediate area.

RGRTA provides bus service to ten (10) City of Rochester High Schools. Each high school has on average 15 school routes that ultimately traverse the study area. Bus traffic serving the west and north side of the City traverse the study area as well.

2.3.2.4. Airports, Railroad Stations, and Ports –

There are no airports, railroad stations or port entrances within or in the vicinity of the project limits.

2.3.2.5. Access to Recreation Areas (Parks, Trails, Waterways, State Lands) –

There are no entrances to recreation areas within the immediate project limits. Wadsworth Park utilizes on-street parking along Broadway and Marshall Street for access to this public open space.

2.3.3. Infrastructure

2.3.3.1. Existing Highway Section –

The Inner Loop expressway within the study limits is a four to six lane divided expressway with parallel two to three lane frontage roads (Pitkin Street and South Union Street) on each side. Most of the expressway within the project limits is depressed via retaining walls 15-20ft below the adjacent frontage roads. The frontage roads and the Inner Loop are connected with entrance and exit ramps located at service points along the system. The combination of the Inner Loop and frontage road system results in a facility that in some places has as many as twelve travel lanes and occupies a width of 180 feet to 350 feet (frontage road outside curb to frontage road outside curb). The Inner Loop expressway has interchanges at Monroe Avenue/Chestnut Street, and University Avenue/East Main Street, via a series of slip ramps from the frontage roads, which also provide access to Broad Street and East Avenue.

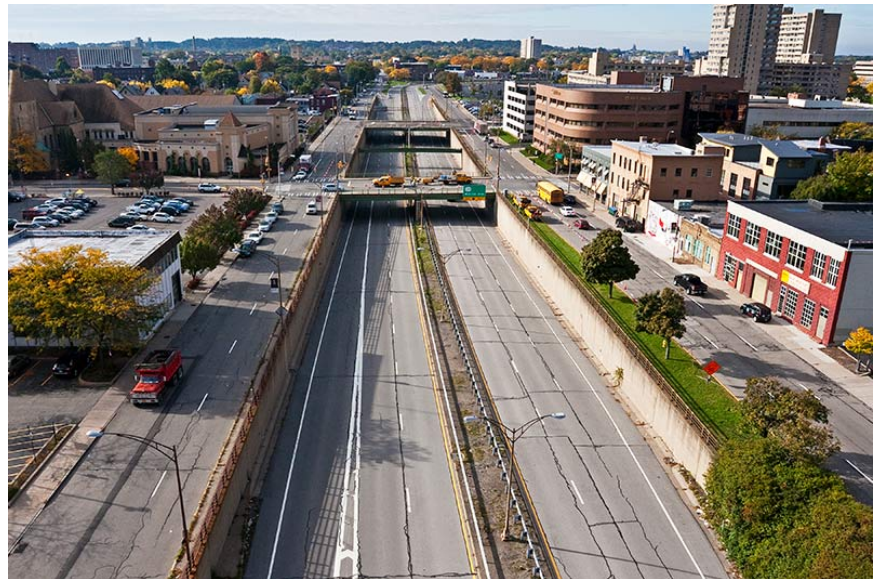

2.3.3.2. Geometric Design Elements Not Meeting Minimum Standards –

2.3.3.2.(1) Critical Design Elements –

Based on the existing estimated 85th percentile speed of 50mph, the existing Inner Loop expressway has a number of non-standard highway features (listed below).

Non-Standard Features for Inner Loop Expressway		
Element	Standard	Existing Condition
Mainline		
Design Speed	50 mph (Minimum) HDM Section 2.7.1.2 A	50 mph (1)
Shoulder Width	Right Side: 10 ft. (Minimum), 12 ft. (Desirable) Left Side: 4 ft. (Minimum), 6 ft. (Desirable with Barrier) HDM Sections 2.7.1.2 C, Exhibit 2-2	2 ft. – 4 ft. 1 ft.
Maximum Grade	4% HDM Section 2.7.1.2 E, Exhibit 2-2	(Between Monroe and Broad) 4.15%. (SB) 4.12%. (NB)
Horizontal Curvature	833 ft. @ e=6.0% HDM Section 2.7.1.2 F	(Between Monroe and Broad) 714 ft. (SB) 719.5 ft. (NB)
Superelevation Rate	6.0% Maximum HDM Section 2.7.1.2 G	(Between Monroe and Broad) 2.0 % (6% Required)(SB & NB)
Stopping Sight Distance	425 ft. HDM Section 2.7.1.2 H, Exhibit 2-2	200 ft. (NB & SB – Under Monroe) 300 ft. (NB & SB – Under Broad) 280 ft. (SB – Under Main)
Ramps		
Design Speed	30 mph (Minimum) HDM Section 2.7.5.2 A	30 mph (1)
Horizontal Curvature	231 ft. @ e=6.0% HDM Section 2.7.5.2 F, Exhibit 2-13	187 ft. (NB Exit to union Near Buena) 175 ft. (SB Ent. to union Near Buena) 200 ft. (SB Ent. to union Near Buena)

1) The Regional Traffic Engineer has concurred that the use of a Design Speed of 50 mph is consistent with the anticipated off-peak 85th percentile speed within the range of functional class speeds for the terrain and volume. (Refer to Section 2.3.1.5 Speeds and Delays for additional information on speed data).

In the review of the adjacent frontage roads, the following non-standard highway features were found based on the existing estimated 85th percentile speed of 30mph,

Non-Standard Features for Other Roads		
Element	Standard	Existing Condition
Howell Street		
Design Speed	30 mph (Minimum) HDM Section 2.7.4.2 A	30 mph (1)
Horizontal Curvature	250 ft. @ e _{max} = 4% HDM Section 2.7.2.2 F	60 ft. (Near Union Street)
Superelevation Rate	4.0% Maximum HDM Section 2.7.2.2 G, Exhibit 2-11	NC (4% Required) (Near Union St.)
Pitkin Street		
Design Speed	30 mph (Minimum) HDM Section 2.7.4.2 A	30 mph (1)
Horizontal Curvature	250 ft. @ e _{max} = 4% HDM Section 2.7.4.2 F	200 ft. (Between East & Charlotte)
Superelevation Rate	4.0% Maximum HDM Section 2.7.4.2 G, Exhibit 2-11	NC (4% Required) (Between East & Charlotte)

1) The Regional Traffic Engineer has concurred that the use of a Design Speed of 30 mph is consistent with the anticipated off-peak 85th percentile speed within the range of functional class speeds for the terrain and volume. (Refer to Section 2.3.1.5 Speeds and Delays for additional information on speed data).

2.3.3.2. (2) Other Design Parameters -

The following non-conforming features were identified:

- Ramp Spacing – All of the Inner Loop access ramps have non-conforming ramp spacing. This inadequate spacing results in several weaving concerns throughout the corridor.
- Ramp Acceleration/Deceleration
- Retaining Walls Safety Railing- The original steel bridge railings along the top of the walls does not meet current standards.
- Fixed Objects – Several fixed objects (light poles, sign structures, etc.) are not properly protected or designed with breakaway features.

2.3.3.3. Pavement and Shoulder -

The Inner Loop mainline pavement section consists of concrete with asphalt overlays and was most recently overlaid in 2005-2006. The pavement condition of the Inner Loop was given a 6 rating (out of 10) by NYSDOT in 2010. This rating equates to “fair condition”. Longitudinal cracks along the pavements seams and some transverse cracks along the underlying concrete joints are prevalent throughout the corridor. There are a few patched areas or areas with local surface breakdown.



The Pitkin Street and Union Street frontage roads are in fair to poor condition. There is a significant amount of both longitudinal and transverse cracking. There is also a fair amount of patch work pavement in areas along the frontage roads.



2.3.3.4. Drainage Systems -

Drainage along the project corridor consists of a closed drainage system with drainage inlets along the medians and shoulders. The drainage system has various sizes and types of drainage conduit. The corridor contains curbing with the exception of the depressed Inner Loop mainline segments that utilizes concrete gutters adjacent to the retaining walls to convey surface flows to the drainage inlets.

The closed drainage system along the Inner Loop mainline drains to a storm sewer line that is in the center median of the Inner Loop. The storm sewer then discharges to the combined sewer system at both the north and south ends. The Union Street stormwater runoff generally flows north and continues along the Main Street corridor to the northeast. The Pitkin Street stormwater runoff drains into a storm sewer along Pitkin Street that outfall’s into the combined sewer system as well. The Howell Street stormwater runoff flows toward Monroe Avenue and continues southeast along Monroe Avenue.

All of the existing stormwater drainage systems within the project limits connect to the combined sewer system before eventually discharging to the overflow tunnel system and then to a sewage treatment facility.

The existing drainage system is generally in fair working condition. There are areas however where the existing drainage structures are deteriorated due to wear and tear and therefore should be addressed, while other isolated areas on the pavement surface frequently pond during rain events due to imperfections in the pavement surface and/or inadequately positioned drainage structures.



2.3.3.5. Geotechnical –

A visual inspection of the depressed Inner Loop Corridor has identified areas of exposed rock near East Main Street. Assuming the project will not include the construction of new roadway bridges or similar structures, an in-depth geotechnical evaluation is not needed. Soil borings will be taken during the Final Design Phase to identify rock elevations.

There are no special geotechnical concerns with the soils or rock slopes within the project area.

2.3.3.6. Structure –

There are eight bridges within close proximity to the project, with four (Monroe Avenue, Broad Street, Utility Bridge, and East Avenue) located within the main project limits. The structures are listed below in Exhibit 2.3.3.6 in order from southwest to northeast. Structures listed below that will be affected by the proposed project are shaded in red.

Exhibit - 2.3.3.6 Existing Structures			
BIN	Feature Carried/Crossed	Structure Type	Year Built
1093880	Ramp LE over I-490	Pre-Stressed Concrete	1974
1050139	Inner Loop over Ramp LB	Single-Span Steel Multi-Girder	1974
1077590	South Clinton Avenue over Inner Loop	Three-Span Steel Multi-Girder	1971 ¹
1021630	Monroe Avenue over Inner Loop	Single-Span Steel Multi-Girder	1957 ²
1050149	Broad Street over Inner Loop	Two-Span Steel Multi-Girder	1965
1050150	Steam Pipe Bridge over Inner Loop	Single-Span Steel Two-Girder	1966
1035240	East Avenue over Inner Loop	Two-Span Steel Multi-Girder	1965
1050160	East Main Street over Inner Loop	Two-Span Steel Multi-Girder	1965

Note:

1. South Clinton Avenue over Inner Loop was rehabilitated in 2001.
2. Monroe Avenue bridge deck was replaced and abutments rehabilitated in 2000.

Also, between South Clinton Avenue and East Main Street, the Inner Loop is lined with concrete retaining walls in two areas. The first retaining wall system begins approximately 150 feet east of South Clinton Street Bridge and ends approximately 650 feet northeast of Monroe Avenue Bridge. The second retaining wall system begins approximately 475 feet south of Broad Street Bridge and ends approximately 650 feet north of East Avenue Bridge.

These walls line both sides of the Inner Loop and they accommodate the grade difference between the adjacent frontage road level and the lower alignment of the Inner Loop. The bridge abutments at Monroe Avenue, Broad Street, the Steam Pipe Bridge, and East Avenue are supported on top of the retaining walls. The total retaining wall surface area is approximately 70,000 square feet.

The first section of retaining walls takes the Inner Loop under Monroe Avenue (built in 1957), and the second section of retaining walls that takes the Inner Loop under Broad Street and East Avenue (constructed in 1963). Considering their age, the majority of the existing walls are in relatively good structural condition. There are isolated areas of minor deterioration, mostly concentrated below the existing bridges due to bridge joint leakage and deicing salt. The original steel bridge railings along the top of the walls do not meet current standards.

2.3.3.6. (1) Description:

Ramp LE over I-490

- (a) BIN - 10938880
- (b) Feature carried and crossed – Ramp LE over I-490
- (c) Type of bridge, number and length of spans, etc. – Pre-Stressed Continuous Concrete, 3 Spans, 87 ft., 117 ft., and 87 ft.
- (d) Width of travel lanes, parking lanes, and shoulders – Left Lane is 12 ft., Right Lane is 14 ft.
- (e) Sidewalks – 8 ft. wide on Right Side
- (f) Utilities carried – None

Inner Loop over Ramp LB

- (a) BIN - 1050139
- (b) Feature carried and crossed – Inner Loop over Ramp LB
- (c) Type of bridge, number and length of spans, etc. – Steel Multi-Girder, 1 Span, 86 ft.
- (d) Width of travel lanes, parking lanes, and shoulders – 12 ft. Lanes, 2 ft. Shoulders, 15 ft. Curbed Median
- (e) Sidewalks – 9.5 ft. wide on both sides
- (f) Utilities carried – Electric and Telephone

South Clinton Avenue over Inner Loop

- (a) BIN - 1077590
- (b) Feature carried and crossed – South Clinton Avenue over Inner Loop
- (c) Type of bridge, number and length of spans, etc. – Steel Multi-Girder, 3 Span, 121 ft., 162 ft., and 120 ft.
- (d) Width of travel lanes, parking lanes, and shoulders – 12 ft. Lanes, 2 ft. Shoulders
- (e) Sidewalks – 9.8 ft. wide on right sides
- (f) Utilities carried – Electric

Monroe Avenue over Inner Loop

- (a) BIN - 102630
- (b) Feature carried and crossed – Monroe Avenue over Inner Loop
- (c) Type of bridge, number and length of spans, etc. – Steel Multi-Girder, 1 Span, 101 ft.
- (d) Width of travel lanes, parking lanes, and shoulders – 12 ft. Lanes, 2 ft. Shoulders
- (e) Sidewalks – 9.5 ft. wide on both sides
- (f) Utilities carried – Electric, Gas, and Telephone

Broad Street over Inner Loop

- (a) BIN – 1050149
- (b) Feature carried and crossed – Broad Street over Inner Loop
- (c) Type of bridge, number and length of spans, etc. – Steel Multi-Girder, 2 Span, 53 ft. and 53 ft.
- (d) Width of travel lanes, parking lanes, and shoulders – 12 ft. Lanes, 2 ft. Shoulders, 4 ft. Curbed Median
- (e) Sidewalks – 7.8 ft. wide on both sides
- (f) Utilities carried – Electric and Telephone

Steam Pipe Bridge over Inner Loop

- (a) BIN - 1050150
- (b) Feature carried and crossed – Steam Pipe over Inner Loop
- (c) Type of bridge, number and length of spans, etc. – Steel Two-Girder, 1 Span, 106 ft.
- (d) Width of travel lanes, parking lanes, and shoulders – none
- (e) Sidewalks – none
- (f) Utilities carried – Steam, Electric, and Gas

East Avenue over Inner Loop

- (a) BIN - 1035240
- (b) Feature carried and crossed – East Avenue over Inner Loop
- (c) Type of bridge, number and length of spans, etc. – Steel Multi-Girder, 2 Span, 53 ft. and 53 ft.
- (d) Width of travel lanes, parking lanes, and shoulders – 10 ft. Lanes, 4 ft. Shoulders
- (e) Sidewalks – 8.0 ft. wide on both sides
- (f) Utilities carried – Electric, Telephone, and Unknown Utility

East Main Street over Inner Loop

- (a) BIN - 1050160
- (b) Feature carried and crossed – East Main Street over Inner Loop
- (c) Type of bridge, number and length of spans, etc. – Steel Multi-Girder, 2 Span, 45 ft. and 42 ft.
- (d) Width of travel lanes, parking lanes, and shoulders – 12 ft. Lanes, 2 ft. Shoulders
- (e) Sidewalks – 8.0 ft. wide on both sides
- (f) Utilities carried – Electric and Telephone

2.3.3.6. (2) Clearances (Horizontal/Vertical) –

The clearances are listed below in Exhibit 2.3.3.6(2).

Exhibit - 2.3.3.6.(2) Horizontal and Vertical Clearances			
BIN	Feature Carried/Crossed	Horizontal	Vertical
1093880	Ramp LE over I-490	30'-6"	14'-5"
1050139	Inner Loop over Ramp LB	48'-0"	14'-4"
1077590	South Clinton Avenue over Inner Loop	54'-2"	14'-1"
1021630	Monroe Avenue over Inner Loop	54'-0"	14'-3"
1050149	Broad Street over Inner Loop	36'-0"	14'-5"
1050150	Steam Pipe Bridge over Inner Loop	N/A	14'-2"
1035240	East Avenue over Inner Loop	48'-0"	14'-3"
1050160	East Main Street over Inner Loop	76'-0"	14'-9"

2.3.3.6. (3) History & Deficiencies –

The history and deficiencies are listed below in Exhibit 2.3.3.6(3).

Exhibit - 2.3.3.6.(3) History & Deficiencies				
BIN	Feature Carried/Crossed	Year Built	Year Rehab.	Structural Flags
1093880	Ramp LE over I-490	1974	None	None
1050139	Inner Loop over Ramp LB	1974	2013	None
1077590	South Clinton Avenue over Inner Loop	1971	2001	None
1021630	Monroe Avenue over Inner Loop	1957	2000	Safety
1050149	Broad Street over Inner Loop	1965	None	Red and Safety
1050150	Steam Pipe Bridge over Inner Loop	1966	None	None
1035240	East Avenue over Inner Loop	1965	None	Red and Safety
1050160	East Main Street over Inner Loop	1965	None	Safety

2.3.3.6.(4) Inspection -

The inspections for the bridges are listed below in Exhibit 2.3.3.6(4).

Exhibit - 2.3.3.6.(4) Inspection					
BIN	Feature Carried/Crossed	Last Inspection Date	Federal Sufficiency Rating	NYSDOT Condition Rating	NYSDOT General Rec.
1093880	Ramp LE over I-490	10/28/2011 Biennial	75.4	5.339	6
1050139	Inner Loop over Ramp LB	8/21/2012 Biennial	79.5	5.047	5
1077590	South Clinton Avenue over Inner Loop	8/26/2011 Biennial	73.4	5.986	6

Exhibit - 2.3.3.6.(4) Inspection					
BIN	Feature Carried/Crossed	Last Inspection Date	Federal Sufficiency Rating	NYSDOT Condition Rating	NYSDOT General Rec.
1021630	Monroe Avenue over Inner Loop	6/26/2012 Biennial	77.3	5.983	6
1050149	Broad Street over Inner Loop	9/6/2012 Interim	41.5	4.264	4
1050150	Steam Pipe Bridge over Inner Loop	N/A	N/A	N/A	N/A
1035240	East Avenue over Inner Loop	11/28/2011 Biennial	65.1	4.792	5
1050160	East Main Street over Inner Loop	6/26/2012 Biennial	65.2	4.361	4

2.3.3.6. (5) Restrictions –

The restrictions for the bridges are listed below in Exhibit 2.3.3.6(5).

Exhibit - 2.3.3.6.(5) Restrictions				
BIN	Feature Carried/Crossed	Closed	Posted Weight Limit	Vertical
1093880	Ramp LE over I-490	No	None	Not Posted
1050139	Inner Loop over Ramp LB	No	None	Not Posted
1077590	South Clinton Avenue over Inner Loop	No	None	Not Posted
1021630	Monroe Avenue over Inner Loop	No	None	Not Posted
1050149	Broad Street over Inner Loop	No	None	Not Posted
1050150	Steam Pipe Bridge over Inner Loop	Utility	None	Not Posted
1035240	East Avenue over Inner Loop	No	R-Permit	Not Posted
1050160	East Main Street over Inner Loop	No	None	Not Posted

2.3.3.6. (6) Future Conditions –

In general, all of the bridges in the project area will continue to deteriorate. If any of the bridges are deemed unsafe for normal traffic, the bridges could possibly be posted or posted with a further reduced loading, and eventually closed to all traffic.

2.3.3.6. (7) Waterway –

A Coast Guard Checklist is not required.

2.3.3.7. Hydraulics of Bridges and Culverts –

There are no bridges or culverts over waterways within the project limits.

2.3.3.8. Guide Railing, Median Barriers and Impact Attenuators –

There are several different types of railing and barriers within the project limits that protect the traveling public from fixed roadside objects, non-traversable slopes, and crossing over to opposing lanes of traffic on the Inner Loop.

Along the median for the Inner Loop, there is a mix of Heavy Post W-Beam Median Barrier, Heavy Post W-Beam Guide Railing and Box Beam Guide Railing from South Clinton Street to East Main Street. In general, the existing condition of the barrier and railing is in good condition.

Along the existing retaining walls and bridges, there is bridge railing. The bridge railing for the Monroe Avenue Bridge is in good condition and meets current standards. The bridge railing along the top of both retaining wall systems and along the bridges at Broad Street, East Avenue, and East Main Street are the original steel bridge railings that were installed in the 1950's and 60's when the Inner Loop was originally constructed. This original steel railing is in fair to poor condition and does not meet current standards, including the lack of proper end treatments.

2.3.3.9. Utilities –

A majority of the utilities within the project area is underground. There are a few areas where some of the utilities are above ground. In general, the conditions of the existing private utility facilities are unknown. The condition of the public utility facilities are generally in good condition.

The underground and overhead electric and the underground gas systems are owned by Rochester Gas and Electric.

The underground steam system is owned by the Rochester District Heating Cooperative.

The underground and overhead telephone systems are owned by Frontier Telephone.

The underground and overhead cable television systems are owned by Time Warner Communications.

The water distribution and fire protection system are owned by the City of Rochester.

The street lighting system is owned by the City of Rochester.

The existing traffic signal and inner connect system is owned by Monroe County Department of Transportation with one exception, the signal at Monroe / Chestnut intersections is owned by NYSDOT.

2.3.3.10. Railroad Facilities –

There are no railroads within the project limits and no at-grade crossings within 0.5 miles that could impact traffic conditions.

2.3.4. Potential Enhancement Opportunities

This section focuses on the existing areas to identify potential enhancement opportunities related to the project and to help avoid and minimize impacts. Chapter 4 focuses on the impacts, enhancements, and mitigation.

2.3.4.1. Landscape -

The existing Inner Loop corridor has limited areas of landscaping. A majority of the landscaping is along the surface streets on either side of the Inner Loop. Where there is landscaping, it is generally gentle slopes with a grass surface, tree lawn with some mature trees.

2.3.4.1. (1) Terrain -

The terrain along the Inner Loop is classified as flat terrain.

2.3.4.1. (2) Unusual Weather Conditions-

There are no unusual weather conditions within the project area.

2.3.4.1. (3) Visual Resources -

The portion of Inner Loop being studied splits the eastern edge of downtown from the residential east side of the city. Downtown Rochester is along the north and west sides and the residential homes are along the south and east sides of the Inner Loop in this area. A visual Impact Assessment has been completed and describes existing visual resources within the project limits.

See Appendix I for further information.

2.3.4.2. Opportunities for Environmental Enhancements –

There are a few areas that will have practical opportunities for possible environmental enhancements in the project limits. These enhancements could include but not be limited to a mix of pocket parks, infilling the existing tree lawns with new street trees and planting rain gardens in appropriate places.

2.3.5. Miscellaneous

There are no miscellaneous topics of discussions.

CHAPTER 3 – ALTERNATIVES

This chapter discusses the alternatives considered and examines the engineering aspects for all feasible alternatives to address project objectives listed in Chapter 1 of this report.

This project concentrates on the 1-mile long segment of the Inner Loop from East Main Street at the north end of the corridor to South Clinton Avenue at the south end. Two (2) options were considered for this segment. The first option would be to retain the expressway and continue maintaining the facility for the foreseeable future. The second Option (Alternative 1) that was considered was to remove the depressed expressway altogether and replace it with an urban arterial city street that combines the user demand from both Union and Pitkin Streets.

3.1. Alternatives Considered and Eliminated from Further Study

The following alternatives were considered and are recommended for elimination from further study based on a review of the project needs and objectives.

Null Alternative

Under this alternative, the basic infrastructure would be retained and maintenance and rehabilitation efforts would be performed by the State, along with City forces, to extend the service life of the existing pavement, structures and adjoining service roads and intersections. The original facility was built in 1965 and eventually will need significant investment.

Overall the existing expressway system and frontage road layout will require on-going and long term investment to maintain:

- 1) The excessive underutilized expressway and frontage road system (four/six lane expressway plus two/three lane frontage roads)
- 2) Retaining walls
- 3) Bridges at East Avenue, Broad Street and Monroe Avenue.

This option also would not address non-standard or non-conforming design features.

Maintaining the existing transportation network as is also does not consider the broader community needs that include providing facilities for non-motorized users; breaking down superblocks that inhibit accessibility to neighborhoods and nearby businesses and civic places; does not allow for optimal use of the available real estate within the Center City; and does not consider the importance of reconnecting the neighborhoods and Center City to ensure long term sustainability. For the aforementioned reasons, this alternative has been eliminated from further consideration.

3.2. Feasible Build Alternatives

3.2.1. Description of Feasible Alternatives

Alternative 1 - Removal of the Inner Loop (Clinton Avenue to Richmond Street)

This alternative considers the complete removal of the Inner Loop and filling in the vacated depressed corridor between Clinton Avenue and Richmond Street such that it matches existing adjoining grades on either side of the expressway. As part of the Inner Loop removal effort, this alternative includes the reconstruction of Union Street, as a two-way facility from Monroe Avenue to East Main Street, on its existing alignment along the east side of the expressway corridor as an urban arterial city street. Pitkin Street from East Avenue to Charlotte Street would be reconstructed as a one-way street with on-street parking. The section of Pitkin Street from Chestnut Street to East Avenue would be eliminated.

The existing Inner Loop expressway at the northern project limit will terminate via exit/entrance ramps that connect to the newly reconstructed Union Street near the Richmond Street intersection. At the south end, the existing I-490 ramps will continue to traverse under Clinton Avenue, but will maintain the adjoining existing topography to create an at-grade intersection with Monroe Avenue / Chestnut Street intersection. The newly constructed road (Howell Street) will then traverse at-grade from the Monroe / Chestnut intersection to South Union Street, thereby creating a 4-way intersection at Lafayette Park.

With the elimination of the depressed expressway corridor, significant quantities of existing reinforced concrete retaining walls will no longer be required and three (3) existing bridges at Monroe Avenue, Broad Street and East Avenue will be removed and replaced with at-grade roadways that will connect directly to the newly reconstructed Union Street. Further addressing the need to reestablish the city grid system and reconnect neighborhoods and business districts, Charlotte Street will be reconnected as it existed prior to the Inner Loop construction.

New and/or upgraded signalization will occur at the following intersections within the project limits:

- East Main Street / North Union Street
- University Avenue / North Union Street
- East Avenue / South Union Street
- Broad Street / South Union Street
- Howell Street / South Union Street
- Monroe Avenue / Chestnut / Howell Street / I-490 Ramps
- Monroe Avenue / South Union Street

On-street parking and streetscape amenities including street lighting enhancements will be included. Pedestrian accommodations will be provided within the project corridor with all features being designed in conformance with ADA standards. The project will incorporate a two-way cycle track for bicyclists along Union / Howell from Monroe Avenue to University Avenue.

The vacant land masses that will be created by the removal of the expressway, retaining walls and bridges along the west side of Union Street will then become available for future residential, business, commercial and/or institutional development.

See Appendix A for plans, profiles and typical sections for Alternative 1.

3.2.2 Preferred Alternative

Alternative 1 is the preferred option, as continuing to maintain the existing facility as is will not meet the project goals and objectives. This alternative will meet the overall project goals and objectives by eliminating the expressway system and creating a community-scale urban arterial city street that can accommodate the projected traffic, allow for economic re-development and enhance community cohesion.

Implementation of Alternative 1 will eliminate the need to maintain, rehabilitate or replace:

- Three (3) multi-span bridges;
- 70,000 square feet of retaining walls;
- Minimum of four (4) lane miles of the Inner Loop expressway system;
- Three (3) miles of highway shoulders, along with guide rail and other highway features.

This recommended Alternative 1, intended to transform the limited access expressway to an urban arterial city street will therefore reduce the life-cycle costs to FHWA, NYSDOT, and the City of Rochester, which all maintain or fund repairs and improvements to this transportation facility.

3.2.3. Design Criteria for Feasible Alternative(s)

3.2.3.1. Design Standards -

3.2.3.2. Critical Design Elements -

Design standards for the various elements of the project are shown in the following Critical Design Elements tables.

Critical Design Elements for Urban Minor Arterials Howell Street (East), Union Street, Monroe Avenue, Chestnut Street, Broad Street, East Avenue					
PIN:		4940.T7	NHS (Y/N):		No / Yes (Chestnut Only)
Route No. & Name:		See Title Above	Functional Class:		Urban Minor Arterial
Project Type:		Reconstruction	Design Class:		Arterial
% Trucks:		Varies (2% - 5%)	Terrain:		Level
ADT:		Varies (5,500 – 21,500)	Truck Access/Qualifying Hwy.		No
Element		Standard		Existing Condition	Proposed Condition
1	Design Speed	30 mph (Minimum) HDM Section 2.7.2.2 A		30 mph	30 mph (1)
2	Lane Width	Travel Lane: 11 ft. (minimum) Wide Travel Lane: 12 ft. (minimum); 14 ft. (desirable) Turning Lane: 11 ft. (minimum); 12 ft. (desirable) Two-Way Left Turn Lane: 11 ft. (min); 16 ft. (des.) Parking Lane: 8 ft. (minimum); 12 ft. (desirable) HDM Sections 2.7.2.2 B, Exhibit 2-4 Bike Lane: 5 ft. HDM Section 17.4.7, Exhibit 17-3, 17-4		11 ft. 12 ft. 11 ft. 11 ft. 8 ft. None	11 ft. 12 ft. 11 ft. 11 ft. 8 ft. 5 ft.
3	Shoulder Width (Curbed)	Left Shoulder for divided arterials: 0 ft. (min.); 2 ft. (des.) Right Shoulder for Bicycling, Lateral Offset, Etc.: 5 ft. (Min.) Right Shoulder for Breakdowns, Turning Movements: 6 ft. (min.) Wide Travel Lanes: 0 ft. to 4 ft. HDM Sections 2.7.2.2 C, Exhibit 2-4		0 ft. NA NA 0 ft.	0 ft. NA NA 0 ft.
4	Bridge Roadway Width	Full width of planned roadway. If on the NHS, HDM Chapter 2 roadway widths shall be met. Bridge Manual, Section 2.3		NA	NA
5	Maximum Grade	8% HDM Section 2.7.2.2 E, Exhibit 2-4		1.25%	2.0%
6	Horizontal Curvature	250 ft. @ $e_{max} = 4\%$ HDM Section 2.7.2.2 F		60 ft. (Howell)	250 ft.
7	Superelevation Rate	4.0% Maximum HDM Section 2.7.2.2 G, Exhibit 2-11		NC* (Howell)	NC* (Howell)
8	Stopping Sight Distance	200 ft. HDM Section 2.7.2.2 H, Exhibit 2-4		200 ft.	215 ft.
9	Horizontal Clearance	0 ft. w/ barrier; 1.5 ft. w/o barrier, 3 ft. at intersections HDM Section 2.7.2.2 I		0 ft. w/ barrier; 1.5 ft. w/o barrier, 3 ft. at intersections	0 ft. w/ barrier; 1.5 ft. w/o barrier, 3 ft. at intersections
10	Vertical Clearance	14'-0" (minimum); 14'-6" (desirable) Bridge Manual, Section 2.4		NA	NA
11	Pavement Cross Slope	Travel Lanes - 1.5% Min. to 2% Max. Parking Lanes - 1.5% Min. to 5% Max. HDM Section 2.7.2.2 K		2.0% 2.0%	2.0% 2.0%
12	Rollover	4.0% between lanes; 8% at edge of traveled way HDM Section 2.7.2.2 L		4.0%	4.0%

Critical Design Elements for Urban Minor Arterials Howell Street (East), Union Street, Monroe Avenue, Chestnut Street, Broad Street, East Avenue			
PIN:	4940.T7	NHS (Y/N):	No / Yes (Chestnut Only)
Route No. & Name:	See Title Above	Functional Class:	Urban Minor Arterial
Project Type:	Reconstruction	Design Class:	Arterial
% Trucks:	Varies (2% - 5%)	Terrain:	Level
ADT:	Varies (5,500 – 21,500)	Truck Access/Qualifying Hwy.	No
Element	Standard	Existing Condition	Proposed Condition
13 Structural Capacity	New/Replacement: AASHTO HL-93 live load and the NYSDOT Design Permit Vehicle Rehabilitation: HS 20 Live Load Bridge Manual, Section 2.6	NA	NA
14 Level of Service	NA	NA	NA
15 Control of Access	NA	NA	NA
16 Pedestrian Accommodation	5' Sidewalk Complies with HDM Chapter 18 and ADAAG	5 ft. (min.)	5 ft. (min.)
17 Median Width	NA	NA	NA

- 1) The Regional Traffic Engineer has concurred that the use of a Design Speed of 30 mph is consistent with the anticipated off-peak 85th percentile speed within the range of functional class speeds for the terrain and volume. (Refer to Section 2.3.1.5 Speeds and Delays for additional information on speed data).
- 2) An * denotes a non-standard feature. See Section 3.3.3.2 and Appendix E for further information.

Critical Design Elements for Urban Local Streets Charlotte St, Howell St (West), Pitkin St, Savannah St			
PIN:	4940.T7	NHS (Y/N):	No
Route No. & Name:	See Title Above	Functional Class:	Urban Local
Project Type:	Reconstruction	Design Class:	Local
% Trucks:	2%	Terrain:	Level
ADT:	Varies (500 – 1,700)	Truck Access/Qualifying Hwy.	No
Element	Standard	Existing Condition	Proposed Condition
1 Design Speed	30 mph HDM Section 2.7.4.2 A	30 mph	30 mph (1)
2 Lane Width (With Curbing)	Travel Lane: 10 ft. (minimum); 11 ft. (desirable) Wide Travel Lane: 12 ft. (minimum); 14 ft. (desirable) Parking Lane: 7 ft. (minimum); 8 ft. (desirable) HDM Sections 2.7.4.2 B, Exhibit 2-8 Bike Lane: 5 ft. HDM Section 17.4.7, Exhibit 17-3, 17-4	11 ft. 12 ft. 8 ft.	11 ft. 12 ft. 8 ft.
3 Shoulder Width (Curbed)	Left Shoulder for divided arterials: 0 ft. (min.); 2 ft. (des.) Right Shoulder for Bicycling, Lateral Offset, Etc.: 5 ft. (Min.) Right Shoulder for Breakdowns, Turning Movements: 6 ft. (min.) Wide Travel Lanes: 0 ft. to 4 ft. HDM Sections 2.7.4.2 C, Exhibit 2-8	NA NA NA 0 ft.	NA NA NA 0 ft.
4 Bridge Roadway Width	Full approach roadway width, but never less than Table R of Appendix 2A or greater than Table N of Appendix 2A.; Bridge Manual, Section 2.3	NA	NA
5 Maximum Grade	8% (Commercial/Industrial); 15% (Residential) HDM Section 2.7.4.2 E, Exhibit 2-8	1.5%	2.5%
6 Horizontal Curvature	250 ft. @ e _{max} = 4% HDM Section 2.7.4.2 F, Exhibit 2-8	200 ft. * (Pitkin)	275 ft.
7 Superelevation Rate	4.0% Maximum HDM Section 2.7.4.2 G, Exhibit 2-11	NC	2%

Critical Design Elements for Urban Local Streets Charlotte St, Howell St (West), Pitkin St, Savannah St				
PIN:		4940.T7	NHS (Y/N): No	
Route No. & Name:		See Title Above	Functional Class: Urban Local	
Project Type:		Reconstruction	Design Class: Local	
% Trucks:		2%	Terrain: Level	
ADT:		Varies (500 – 1,700)	Truck Access/Qualifying Hwy. No	
Element		Standard	Existing Condition	Proposed Condition
8	Stopping Sight Distance	200 ft. HDM Section 2.7.4.2 H, Exhibit 2-8	250 ft.	250 ft.
9	Horizontal Clearance	0 ft. w/ barrier; 1.5 ft. w/o barrier, 3 ft. at intersections HDM Section 2.7.2.2 I	0 ft. w/ barrier; 1.5 ft. w/o barrier, 3 ft. at intersections	0 ft. w/ barrier; 1.5 ft. w/o barrier, 3 ft. at intersections
10	Vertical Clearance	14'-0" (minimum); 14'-6" (desirable) Bridge Manual, Section 2.4	NA	NA
11	Pavement Cross Slope	Travel Lanes - 1.5% Min. to 2% Max. Parking Lanes - 1.5% Min. to 5% Max. HDM Section 2.7.2.2 K	2.0% 2.0%	2.0% 2.0%
12	Rollover	4.0% between lanes; 8% at edge of traveled way HDM Section 2.7.4.2 L	4.0%	4.0%
13	Structural Capacity	New/Replacement: AASHTO HL-93 live load and the NYSDOT Design Permit Vehicle Rehabilitation: HS 20 Live Load Bridge Manual, Section 2.6	NA	NA
14	Level of Service	NA	NA	NA
15	Control of Access	NA	NA	NA
16	Pedestrian Accommodation	5' Sidewalk Complies with HDM Chapter 18 and ADAAG	5 ft. (min.)	5 ft. (min.)
17	Median Width	NA	NA	NA

1) The Regional Traffic Engineer has concurred that the use of a Design Speed of 30 mph is consistent with the anticipated off-peak 85th percentile speed within the range of functional class speeds for the terrain and volume. (Refer to Section 2.3.1.5 Speeds and Delays for additional information on speed data).

2) An * denotes a non-standard feature. See Section 3.3.3.2 and Appendix E for further information.

Critical Design Elements for Single Lane Ramps (Inner Loop and I-490)				
PIN:		4940.T7	NHS (Y/N): Yes	
Route No. & Name:		Inner Loop On / Off & I-490 Off	Functional Class: Other Roadways	
Project Type:		Reconstruction	Design Class: Non-Interstate Ramps	
% Trucks:		5%	Terrain: Level	
ADT:		Varies (4,000 – 6,500)	Truck Access/Qualifying Hwy. Qualifying Highway	
Element		Standard	Existing Condition	Proposed Condition
1	Design Speed	30 mph (minimum) Semi-Direct Connection Ramps HDM Section 2.7.5.2 A	NA	30 mph (1)
2	Lane Width	Travel Lane: 14 ft. (Minimum)(Varies by Radii) Traveled Way Width: 21ft. (Minimum)(Varies by Radii) HDM Sections 2.7.5.4 B, Exhibit 2-9b – Case II, Condition C	NA NA	14 ft. – 17 ft. 23 ft. - 26 ft.

Critical Design Elements for Single Lane Ramps (Inner Loop and I-490)				
PIN:		4940.T7	NHS (Y/N):	Yes
Route No. & Name:		Inner Loop On / Off & I-490 Off	Functional Class:	Other Roadways
Project Type:		Reconstruction	Design Class:	Non-Interstate Ramps
% Trucks:		5%	Terrain:	Level
ADT:		Varies (4,000 – 6,500)	Truck Access/Qualifying Hwy.	Qualifying Highway
Element	Standard	Existing Condition	Proposed Condition	
3	Shoulder Width	<p>With Curb 0 ft. (Minimum), 2' Desirable</p> <p>With-out Curb Left Side: 3 ft. (minimum) Right Side: 6 ft. (minimum) HDM Sections 2.7.5.4 B, Exhibit 2-10</p>	<p>NA</p> <p>NA NA</p>	<p>NA</p> <p>3 ft. 6 ft.</p>
4	Bridge Roadway Width	The lane and shoulder widths are to be carried across all ramp structures.	NA	38'
5	Maximum Grade	7% HDM Section 2.7.5.2 E, Exhibit 2-10	NA	4.25%
6	Horizontal Curvature	231 ft. @ e _{max} = 6% HDM Section 2.7.5.2 F, Exhibit 2-10	NA	485 ft. / 150 ft. (3)
7	Superelevation Rate	6.0% Maximum HDM Section 2.7.5.2 G, Exhibit 2-13	NA	6% / 4% (3)
8	Stopping Sight Distance	200 ft. HDM Section 2.7.5.2 H, Exhibit 2-10	NA	202 ft.
9	Horizontal Clearance	Right: Greater of Shoulder Width or 6 ft.; Left: 3 ft.; when ramps pass under structures, there should be an additional 4 ft. clearance beyond outside of shoulders to bridge piers or abutments HDM Section 2.7.5.2 I	NA	0 ft. w/ barrier; 1.5 ft. w/o barrier, 3 ft. at intersections
10	Vertical Clearance	14'-0" (minimum); 14'-6" (desirable) Bridge Manual, Section 2.4	14.09'	14.15'
11	Pavement Cross Slope	1.5% Min. to 2% Max. HDM Section 2.7.5.2 K	NA	2.0%
12	Rollover	4.0% between lanes; 8% at edge of traveled way HDM Section 2.7.5.2 L	NA	0%
13	Structural Capacity	New/Replacement: AASHTO HL-93 live load and the NYSDOT Design Permit Vehicle Rehabilitation: HS 20 Live Load Bridge Manual, Section 2.6	NA	NA
14	Level of Service	NA	NA	NA
15	Control of Access	Fully Controlled, Control should extend beyond ramp terminal at least 100 ft. in Urban areas HDM Section 2.7.5.2 O	NA	NA
16	Pedestrian Accommodation	5' Sidewalk at Ramp Terminals Complies with HDM Chapter 18 and ADAAG	5 ft. (min.)	5 ft. (min.)
17	Median Width	NA	NA	NA

- 1) The Regional Traffic Engineer has concurred that the use of a Design Speed of 30 mph is consistent with the anticipated off-peak 85th percentile speed within the range of functional class speeds for the terrain and volume. (Refer to Section 2.3.1.5 Speeds and Delays for additional information on speed data).
- 2) An * denotes a non-standard feature. See Section 3.3.3.2 and Appendix E for further information.
- 3) Proposed values for ramp terminals. Design speed does not apply to ramp terminals per HDM 2.7.5.2.A.

Critical Design Elements for Multi-Lane Ramps (I-490)					
PIN:		4940.T7	NHS (Y/N):		Yes
Route No. & Name:		I-490 On / Off	Functional Class:		Other Roadways
Project Type:		Reconstruction	Design Class:		Non-Interstate Ramps
% Trucks:		5%	Terrain:		Level
ADT:		Varies (6,500 – 20,500)	Truck Access/Qualifying Hwy.		Qualifying Highway
Element		Standard		Existing Condition	Proposed Condition
1	Design Speed	30 mph (minimum) Semi-Direct Connection Ramps HDM Section 2.7.5.2 A		NA	30 mph (1)
2	Lane Width	Travel Lane: 12 ft. (Minimum)(Varies by Radii) Traveled Way Width: 28ft. (Minimum)(Varies by Radii) HDM Sections 2.7.5.4 B, Exhibit 2-9b – Case III, Condition C		NA NA	12 ft. 28 ft.
3	Shoulder Width	<u>With Curb</u> 0 ft. (Minimum), 2' Desirable		NA	2 ft.
		<u>With-out Curb</u> Left Side: 3 ft. (minimum) Right Side: 6 ft. (minimum) HDM Sections 2.7.5.4 B, Exhibit 2-10		NA NA	8 ft.
4	Bridge Roadway Width	The lane and shoulder widths are to be carried across all ramp structures.		48'	48'
5	Maximum Grade	7% HDM Section 2.7.5.2 E, Exhibit 2-10		NA	0.86%
6	Horizontal Curvature	231 ft. @ $e_{max} = 6\%$ HDM Section 2.7.5.2 F, Exhibit 2-10		NA	NA / 1000 ft.(3)
7	Superelevation Rate	6.0% Maximum HDM Section 2.7.5.2 G, Exhibit 2-13		NA	NC / NC (3)
8	Stopping Sight Distance	200 ft. HDM Section 2.7.5.2 H, Exhibit 2-10		NA	305 ft.
9	Horizontal Clearance	Right: Greater of Shoulder Width or 6 ft.; Left: 3 ft.; when ramps pass under structures, there should be an additional 4 ft. clearance beyond outside of shoulders to bridge piers or abutments HDM Section 2.7.5.2 I		NA	0 ft. w/ barrier; 1.5 ft. w/o barrier, 3 ft. at intersections
10	Vertical Clearance	14'-0" (minimum); 14'-6" (desirable) Bridge Manual, Section 2.4		14.48'	14.32'
11	Pavement Cross Slope	1.5% Min. to 2% Max. HDM Section 2.7.5.2 K		NA	2.0%
12	Rollover	4.0% between lanes; 8% at edge of traveled way HDM Section 2.7.5.2 L		NA	4.0%
13	Structural Capacity	New/Replacement: AASHTO HL-93 live load and the NYSDOT Design Permit Vehicle Rehabilitation: HS 20 Live Load Bridge Manual, Section 2.6		NA	NA
14	Level of Service	NA		NA	NA
15	Control of Access	Fully Controlled, Control should extend beyond ramp terminal at least 100 ft. in Urban areas HDM Section 2.7.5.2 O		NA	NA
16	Pedestrian Accommodation	5' Sidewalk at Ramp Terminals Complies with HDM Chapter 18 and ADAAG		5 ft. (min.)	5 ft. (min.)
17	Median Width	NA		NA	NA

- 1) The Regional Traffic Engineer has concurred that the use of a Design Speed of 30 mph is consistent with the anticipated off-peak 85th percentile speed within the range of functional class speeds for the terrain and volume. (Refer to Section 2.3.1.5 Speeds and Delays for additional information on speed data).
- 2) An * denotes a non-standard feature. See Section 3.3.3.2 and Appendix E for further information.
- 3) Proposed values for ramp terminals. Design speed does not apply to ramp terminals per HDM 2.7.5.2.A.

Critical Design Elements for Right Turn Slip Ramp (Chestnut to I-490)					
PIN:		4940.T7	NHS (Y/N):		Yes
Route No. & Name:		Inner Loop / I-490	Functional Class:		Other Roadways
Project Type:		Reconstruction	Design Class:		Non-Interstate Ramps
% Trucks:		5%	Terrain:		Level
ADT:		12,000	Truck Access/Qualifying Hwy.		Qualifying Highway
Element		Standard	Existing Condition	Proposed Condition	
1	Design Speed	10 mph (minimum) Free Flow Turning Roadways HDM Section 2.7.5.4 B	10 mph	20 mph (1)	
2	Lane Width	Travel Lane: 18 ft. (Minimum) Traveled Way Width: 26ft. (Minimum) HDM Sections 2.7.5.4 B, Exhibit 2-9b – Case II, Condition C	12 ft. – 14 ft. 26'	18 ft. 28'	
3	Shoulder Width	<u>With Curb</u> 0 ft. (Minimum), 2' Desirable <u>With-out Curb</u> Left Side: 3 ft. (minimum) Right Side: 6 ft. (minimum) HDM Sections 2.7.5.4 B, Exhibit 2-10	0 ft.	2 ft. (Left side) 8 ft. (Right Side)	
4	Bridge Roadway Width	The lane and shoulder widths are to be carried across all ramp structures.	NA	NA	
5	Maximum Grade	8% HDM Section 2.7.5.4 B, Exhibit 2-10	1.2%	1.2%	
6	Horizontal Curvature	86 ft. @ $e_{max} = 4\%$ HDM Section 2.7.5.2 F, Exhibit 2-10	65 ft.	110 ft.	
7	Superelevation Rate	4.0% Maximum HDM Section 2.7.5.4 B, Exhibit 2-11	NC	NC	
8	Stopping Sight Distance	115 ft. HDM Section 2.7.5.4 B, Exhibit 2-10	235 ft.	237 ft.	
9	Horizontal Clearance	Right: Greater of Shoulder Width or 6 ft.; Left: : Greater of Shoulder Width or 4 ft.; HDM Section 2.7.5.4 B	6 ft.' 4 ft.	6 ft. 4 ft.	
10	Vertical Clearance	14'-0" (minimum); 14'-6" (desirable) Bridge Manual, Section 2.4	NA	NA	
11	Pavement Cross Slope	1.5% Min. to 2% Max. HDM Section 2.7.5.2 K	2.0%	2.0%	
12	Rollover	4.0% between lanes; 8% at edge of traveled way HDM Section 2.7.5.2 L	4.0%	0%	
13	Structural Capacity	New/Replacement: AASHTO HL-93 live load and the NYSDOT Design Permit Vehicle Rehabilitation: HS 20 Live Load Bridge Manual, Section 2.6	NA	NA	
14	Level of Service	NA	NA	NA	
15	Control of Access	Fully Controlled, Control should extend beyond ramp terminal at least 100 ft. in Urban areas HDM Section 2.7.5.2 O	NA	NA	

Critical Design Elements for Right Turn Slip Ramp (Chestnut to I-490)			
PIN:	4940.T7	NHS (Y/N):	Yes
Route No. & Name:	Inner Loop / I-490	Functional Class:	Other Roadways
Project Type:	Reconstruction	Design Class:	Non-Interstate Ramps
% Trucks:	5%	Terrain:	Level
ADT:	12,000	Truck Access/Qualifying Hwy.	Qualifying Highway
Element	Standard	Existing Condition	Proposed Condition
16	Pedestrian Accommodation 5' Sidewalk at Ramp Terminals Complies with HDM Chapter 18 and ADAAG	5 ft. (min.)	5 ft. (min.)
17	Median Width	NA	NA

- 1) The Regional Traffic Engineer has concurred that the use of a Design Speed of 30 mph is consistent with the anticipated off-peak 85th percentile speed within the range of functional class speeds for the terrain and volume. (Refer to Section 2.3.1.5 Speeds and Delays for additional information on speed data).
- 2) An * denotes a non-standard feature. See Section 3.3.3.2 and Appendix E for further information.

3.2.3.3. Other Design Parameters -

Exhibit 3.2.3.3 a Other Design Parameters			
Highway or Feature			
Element	Criteria	Proposed Condition	
1	Level of Service (for non – interstate projects)	D	C
2	Drainage Design Storm	10-year storm event	10-year storm event
3	Street Lighting	Average maintained – 1.2 fc Uniformity – 4:1 Avg. / Min.	

3.3. Engineering Considerations

3.3.1. Operations (Traffic and Safety) & Maintenance

3.3.1.1. Functional Classification and National Highway System -

By removing the Inner Loop, Alternative 1 will result in the elimination of the Principal Arterial Expressway on the National Highway System. Union Street will retain a functional classification of a Minor Urban Arterial and Howell Street, between Monroe Avenue and South Union Street, is anticipated to change from an Urban Local Road to a Minor Urban Arterial. All other roadways will retain their existing functional classification.

3.3.1.2. Control of Access -

The new facility will serve as an urban arterial with adjoining land uses requiring driveway access, and therefore the right-of-way will be with access. The I-490 ramps west of Monroe Avenue will retain its right-of-way without access status. In addition the new Inner Loop ramps near the intersection of Richmond Street will also have a short segment of Right-of-Way along Union Street without access. Control of Access will be finalized as part of the land transfer between the City of Rochester and NYS DOT.

3.3.1.3. Traffic Control Devices -

3.3.1.3. (1) Traffic Signals –

Traffic signals are proposed at the following intersections:

- I- 490 Ramps @ Monroe Avenue/Chestnut Street
- South Union Street @ Broad Street
- South Union Street @ East Avenue
- South Union Street @ Howell Street

Existing Traffic Signal Modifications are proposed at the following intersections:

- South Union Street @ Monroe Avenue
- North Union Street @ University Avenue
- North Union Street @ East Main Street

All other intersections within the study limits will remain as is.

3.3.1.3. (2) Signs -

Existing signs will be evaluated and replaced as necessary, and new signs will be added where required.

3.3.1.4. Intelligent Transportation Systems (ITS) –

Intelligent Transportation System (ITS) improvements will include the installation of underground conduit in order to accommodate future hard-wire connections between coordinated traffic signals and the Monroe County Regional Traffic Operations Center (RTOC). In addition two traffic cameras will be included in the proposed alternative as discussed in Section 2.3.1.4. These locations are S. Union Street @ Broad Street or S. Union Street @ East Ave. and Monroe Ave. / Chestnut @ Howell Street

3.3.1.5. Speeds and Delay -

3.3.1.5. (1) Proposed Speed Limit –

The posted speed limit for all City Streets will be 30 mph. The ramp speed limits will retain the posted speed limit of their respective expressway, Inner Loop (45 mph) and I-490 (40 mph), with advisory warning signs where required.

3.3.1.5. (2) Travel Time Estimates –

While travel speeds may be lower than on the previous expressway, overall traffic operations will operate at acceptable levels on the arterial network and accessibility for pedestrian and bicycle traffic will be notably improved. Levels of operations at each of the corridor intersection are projected to be LOS D or better, hence no travel time estimates are required.

3.3.1.6. Traffic Volumes –

The projected traffic volumes are not anticipated to change or increase as a direct result of the preferred alternative. Instead, Inner Loop traffic will be rerouted to the new urban arterial city street. Minor redistribution of traffic along the new street grid system will result with the change of ramp locations and conversion of Union Street to two-way traffic from Monroe Avenue to East Main Street. Alternative 1 uses a higher growth rate (0.75% per year) to forecast future traffic. The higher growth rate accommodates the potential traffic from development of vacated land with removal of the Inner Loop. Refer to Appendix G for traffic flow diagrams.

Exhibit 3.3.1.6 a Traffic Volume Summary						
Location	Null			Alternative 1		
	ETC + 20 (2035)			ETC +20 (2035)		
	ADT	DHV	DDHV	ADT	DHV	DDHV
Inner Loop Expressway						
Monroe Avenue to Broad St.	7,920	680	425	-	-	-
East Main Street to Scio St.	11,935	800	540	11,935	800	540
Union Street						
Howell St. to East Ave.	4,900	490	490	14,000	1,590	768
Richmond St. to University Ave.	6,350	635	635	5,600	608	485
Pitkin Street						
Chestnut to East Ave.	2,700	270	270	-	-	-
East Ave. to E. Main St.	2,300	235	235	470	50	50

3.3.1.7. Level of Service and Mobility –

3.3.1.7 (1) At Project Completion & Design Year –

Development of the intersection geometric and traffic control treatments was an iterative process. Capacity analysis was first used to establish minimum requirements to meet capacity design standards. Various options were identified for each intersection through agency and stakeholder involvement. Each major category of options assessed and evaluated is detailed in a memo titled “Inner Loop East – Intersection Alternatives – Capacity Analysis in Appendix G. This memo breaks down various alternatives at each location including traditional T-intersections, 4-way intersections, off-set intersections, roundabouts, stop sign control, and traffic signal control options. Each of these options was presented at the public meeting and reviewed by various neighborhood stakeholders and each of the agencies involved in the project. Alternative 1 considers not just capacity needs, but also addressed and incorporates pedestrian crossing amenities, bicycle intersection accommodations, and cycle track treatments. Exhibit 3.3.1.7a shows the capacity analysis results at each of the corridor intersections.

Alternative 1 results in intersection LOS of C or better in ETC+20 (2035) for all the intersections within the project limits with the exception of the Union / East intersection. This segment of roadway has recently undergone a road diet changing the original 4-lane section into a 3-lane section (one travel lane in each direction with a center median / turn lane) in order to accommodate on-street parking. The 3-lane section will operate at an overall LOS D with a few movements with high volume/capacity ratios. The intersection was reevaluated utilizing the original 4-lane configuration and resulted in overall LOS C. The City of Rochester will monitor the intersection, and if required in the future, reestablish the 4-lane section to accommodate traffic needs. It should be noted that three intersections (Monroe / Chestnut, Union / Broad and Union / East) within the corridor will require special attention due to the cycle track. A detailed analysis of the cycle track - traffic signal operation, is included in Appendix G. Considering this will be the first two-way cycle track in the region, protected left turn phasing is being recommended at this time. Protected phasing will cause lower levels of operations during the peak hours; however, the safety of various multi-modal users through these intersections is important. Alternative traffic signal phasing and timing that show better intersection capacity operations is provided with advantages and disadvantages outlined in the memo.

Exhibit 3.3.1.7 a Level of Service Table (Alternative 1)							
INTERSECTION	LANE GRPOUP	AM PEAK HOUR			PM PEAK HOUR		
		V/C RATIO	DELAY	LOS	V/C RATIO	DELAY	LOS
Inner Loop/Howell Street & Chestnut Street/Monroe Avenue <i>Signalized</i>	EB-L	0.73	50.3	D	0.70	71.5	E
	EB-TR	0.60	19.2	B	0.53	25.1	C
	WB-TR	0.67	45.8	D	0.95	62.1	E
	NB-L	0.51	23.8	C	0.97	74.4	E
	NB-TR	0.63	24.7	C	0.41	18.6	B
	SB-L	0.27	35.2	D	0.11	24.6	C
	SB-T	0.59	39.6	D	0.92	54.5	D
	SB-R	0.20	0.3	A	0.85	6.6	A
Intersection	-	28.1	C	-	33.9	C	
Howell Street & S Union Street <i>Signalized</i>	EB-LTR	0.54	17.6	B	0.76	28.1	C
	WB-LTR	0.02	10.2	B	0.02	13.8	B
	NB-LTR	0.79	21.5	C	0.50	17.6	B
	SB-LTR	0.66	6.3	A	0.93	22.7	C
	Intersection	-	15.2	B	-	22.6	C
S Union Street & Monroe Avenue <i>Signalized</i>	EB-L	0.31	28.2	C	0.35	33.7	C
	EB-T	0.75	40.5	D	0.50	36.3	D
	WB-TR	0.06	6.2	A	0.12	9.0	A
	NB-L	0.67	30.3	C	0.86	39.9	D
	NB-T	0.02	5.3	A	0.02	15.5	B
	NB-R	0.43	6.7	A	0.54	19.5	B
	SB-LTR	0.63	13.7	B	0.64	13.1	B
	Intersection	-	18.9	B	-	21.2	C
S Union Street & E Broad Street <i>Signalized</i>	EB-L	0.37	39.3	D	0.82	50.5	D
	EB-R	0.21	36.3	D	0.58	38.4	D
	NB-L	0.59	35.7	D	0.39	38.0	D
	NB-T	0.49	4.7	A	0.61	12.0	B
	SB-TR	0.91	27.8	C	0.82	20.4	C
	Intersection	-	19.7	B	-	24.5	C
S Union Street & East Avenue <i>Signalized - 3 Lane Section</i>	EB-L	0.13	18.4	B	0.16	15.5	B
	EB-TR	0.56	34.8	C	0.99	65.2	E
	WB-L	0.51	25.2	C	0.50	23.6	C
	WB-TR	0.84	46.1	D	0.72	32.4	C
	NB-L	0.82	76.0	E	0.41	47.7	D
	NB-TR	0.59	22.2	C	0.95	43.2	D
	SB-L	0.58	19.2	B	0.93	60.7	E
	SB-TR	0.89	55.6	E	0.97	69.4	E
	Intersection	-	37.6	D	-	50.5	D

Exhibit 3.3.1.7 a Level of Service Table (Alternative 1)							
INTERSECTION	LANE GRPOUP	AM PEAK HOUR			PM PEAK HOUR		
		V/C RATIO	DELAY	LOS	V/C RATIO	DELAY	LOS
East Avenue & Pitkin Street <i>Unsignalized</i>	EB-T	0.15	0.0	A	0.39	0.0	A
	WB-T	0.32	0.0	A	0.29	0.0	A
	SB-LR	0.11	16.6	C	0.10	17.3	C
	Intersection	-	0.7	A	-	0.5	A
N Union Street & Charlotte Street <i>Unsignalized</i>	EB-LTR	0.15	17.6	C	0.24	20.9	C
	WB-LTR	0.20	17.0	C	0.32	20.8	C
	NB-LTR	0.20	0.6	A	0.28	0.8	A
	SB-LTR	0.02	0.4	A	0.03	0.7	A
	Intersection	-	1.6	A	-	2.4	A
Charlotte Street & Pitkin Street <i>Unsignalized</i>	EB-TR	0.03	0.0	A	0.04	0.0	A
	WB-LT	0.00	0.2	A	0.00	0.2	A
	SB-LTR	0.07	10.0	A	0.07	10.4	B
	Intersection	-	3.1	A	-	2.4	A
N Union Street & Inner Loop/Richmond Street <i>Unsignalized</i>	EB-LR	0.66	18.6	C	0.74	23.3	C
	WB-R	0.03	10.2	B	0.04	11.7	B
	NB-L	0.28	9.0	A	0.35	9.0	A
	NB-T	0.18	0.0	A	0.32	0.0	A
	SB-TR	0.15	0.0	A	0.08	0.0	A
	Intersection	-	8.8	A	-	9.9	A
N Union Street & University Avenue <i>Signalized</i>	EB-LTR	0.30	3.2	A	0.30	3.2	A
	WB-LTR	0.30	7.9	A	0.29	9.8	A
	NB-LTR	0.72	41.9	D	0.72	22.3	C
	SB-LTR	0.64	51.4	D	0.25	45.9	D
	Intersection	-	18.2	B	-	13.4	B
N Union Street & Main Street <i>Signalized</i>	EB-L	0.13	2.3	A	0.01	1.0	A
	EB-TR	0.57	33.8	C	0.71	29.4	C
	WB-L	0.38	14.3	B	0.20	12.3	B
	WB-TR	0.76	33.0	C	0.72	31.3	C
	NB-LT	0.31	47.3	D	0.32	48.3	D
	NB-R	0.31	26.3	C	0.46	19.7	B
	SB-LTR	0.37	14.2	B	0.25	9.0	A
	Intersection	-	30.3	C	-	28.8	C

Exhibit 3.3.1.7 a Level of Service Table (Alternative 1)							
INTERSECTION	LANE GRPOUP	AM PEAK HOUR			PM PEAK HOUR		
		V/C RATIO	DELAY	LOS	V/C RATIO	DELAY	LOS
University Avenue & Main Street <i>Signalized</i>	EB-L	0.17	29.3	C	0.31	27.5	C
	EB-TR	0.39	24.5	C	0.62	21.5	C
	EB-R	0.27	8.4	A	0.35	4.9	A
	WB-TR	0.92	8.3	A	0.70	3.8	A
	NB-L	0.58	36.4	D	0.49	45.7	D
	NB-LTR	0.56	32.1	C	0.48	42.5	D
	SB-L	0.73	41.4	D	0.70	40.6	D
	SB-LTR	0.72	35.9	D	0.70	36.0	D
	Intersection	-	23.5	C	-	22.6	C
University Avenue/Pitkin Street & Main Street <i>Signalized</i>	EB-L	0.09	26.8	C	0.27	36.3	D
	EB-TR	0.30	24.7	C	0.56	28.7	C
	WB-L	0.02	6.8	A	0.03	6.6	A
	WB-T	0.32	6.6	A	0.25	5.5	A
	WB-R	0.31	1.8	A	0.24	1.5	A
	SB-L	0.21	26.1	C	0.26	27.3	C
	SB-TR	0.06	23.2	C	0.06	22.6	C
	Intersection	-	12.9	B	-	17.4	B

3.3.1.7 (2) – Work Zone Safety & Mobility –

A. Work Zone Traffic Control Plan –

It is anticipated that multiple on-site and off-site detours will be required as part of the project. Access along Union Street and Pitkin Street including parking, will be maintained during construction. Routes for emergency vehicles will be maintained and open during construction. The details for the work zone traffic control will be prepared and evaluated during final design.

B. Special Provisions -

The use of time related provisions will be evaluated during final design. The work zone traffic control will need to be coordinated with local officials and residents.

C. Significant Projects (per 23 CFR 630.1010) -

The Region has determined that the subject project is significant per 23 CFR 630.1010.

A Transportation Management Plan (TMP) will be prepared for the project consistent with 23 CFR 630.1012. The TMP will consist of a Temporary Traffic Control (TTC) plan. Transportation Operations (TO) and Public Information (PI) components of a TMP will be considered during final design.

3.3.1.8. Safety Considerations, Accident History and Analysis –

Several safety improvements will be incorporated into the preferred alternative and are listed below.

At several locations throughout the project corridor, curb bump-outs will be provided to serve as a traffic calming features and also provide a shorter crossing distance for pedestrians. In addition these bump-outs will help protect parked vehicles along the corridor.

The project will also include several pavement marking improvements as part of the project. To provide a longer lasting and higher visibility marking for motorists, the existing pavement striping will be replaced with epoxy reflectorized pavement markings. In addition high visibility crosswalks will be incorporated into the final design.

The project will replace several infrastructure elements within the corridor. Traffic signs will be replaced using the new National Manual of Uniform Traffic Control Devices (MUTCD) and the New York State Supplement to the National MUTCD standards. In addition, the existing traffic signals will be replaced as part of the project.

Safety improvements for pedestrians include countdown timers at signalized intersections, new concrete sidewalks and ADA compliant ramps. In addition, new high visibility crosswalk pavement markings and curb bump outs will aid pedestrians in crossing the existing roadways.

Safety improvements for bicyclists include a two way cycle track to separate cyclists from vehicular traffic. In addition, bike boxes and integration with the traffic signal operations will also improve safety for cyclists.

The horizontal clearance criteria within the project corridor will be 1.5', except at intersections where 3' of clearance would be preferred. Typical encroachments consist of traffic signs, light poles and utility poles and trees. Traffic signs will be replaced and placed to meet the horizontal clearance requirement of 1.5'. Utility poles will be evaluated and relocated to also accommodate the 1.5' horizontal clearance requirement. New street light pole and trees will also maintain a minimum of 1.5' of clearance.

The proposed alternative will result in the elimination of all non-standard and non-conforming features identified in Section 2.3.3.2 associated with the removal of the Inner Loop expressway. The non-standard features on the local network will also be eliminated with the exception of the non-standard superelevation on Howell Street.

3.3.1.9. Impacts on Police, Fire Protection and Ambulance Access -

The impact of the preferred alternative on emergency vehicles that routinely use this route will be temporary during the construction phase of the project. With the re-established grid street system, and providing two-way operations along Union Street from Monroe Avenue to East Main Street, improved circulation and access will result.

3.3.1.10. Parking Regulations and Parking Related Issues –

Union Street will include on-street parking amenities, along both sides, which will also serve to support future land development on the vacant parcels created by the removal of the Inner Loop expressway. In addition, parking lanes have been formalized along Howell and Pitkin streets to increase parking within the project corridor. During the final design phase, the City of Rochester will assess and recommend parking regulations for the corridor.

3.3.1.11. Lighting –

The existing lighting system will be replaced to increase the lighting levels within the project limits. Detailed lighting plans will be developed during the final design phase of the project.

3.3.1.12. Ownership and Maintenance Jurisdiction –

The Inner Loop expressway will be removed, thereby absolving the State of most of its ownership and maintenance responsibilities for the facility's upkeep. The I-490 ramps to Monroe Avenue will remain the ownership and maintenance responsibility of the State. In addition, the new Inner Loop ramps near Richmond Street will remain under NYSDOT jurisdiction.

All other impacted roads will continue to be owned and maintained by the City of Rochester.

All other facilities will retain ownership as described in Section 2.3.1.12.

3.3.1.13. Constructability Review -

The City of Rochester's Department of Environmental Services, Construction division, in conjunction with NYSDOT, will review the final plans for constructability related issues.

3.3.2. Multimodal

3.3.2.1. Pedestrians –

As is the case with most City streets, pedestrian facilities will be provided on both sides of the newly constructed roads and will be designed to conform to ADA standards. Intersections will include appropriately designed cross-walks, sidewalk ramps, and pedestrian signal heads and push buttons. The elimination of the Inner Loop expressway, with its restrictions on pedestrian and bicycle traffic, will correspondingly remove this natural barrier between the Center City and the adjoining neighborhoods thereby improving accessibility for all foot traffic.

3.3.2.2. Bicyclists –

Alternative 1 will effectively reconnect the local grid street system and will provide improved accessibility between the Center City and adjacent neighborhoods through new east/west connections. A dedicated two-way cycle track, which will be physically separated from Union Street, is also proposed from Monroe Avenue to University Avenue.

3.3.2.3. Transit –

RGRTA will need to reroute various existing RTS bus routes to the new at-grade arterial if transit service is desired with the reconnected street grid system. Alternative routes and local stops will be identified during the final design phase in cooperation with RGRTA.

3.3.2.4. Airports, Railroad Stations, and Ports –

No changes are proposed; no conflicts are expected.

3.3.2.5. Access to Recreation Areas (Parks, Trails, Waterways, and State Lands) –

Although the Inner Loop expressway will be removed, the City's original grid system will be reestablished, thus no changes are proposed.

3.3.3. Infrastructure

3.3.3.1. Proposed Highway Section –

Alternative 1, which includes an at-grade arterial (Union and Howell Streets), will typically take the form of a three to four lane curbed city street.

Based on the spacing of intersections and adjacent parcel access, center flush medians and left turn lanes will also be provided. The posted speed limit along the new arterial will be 30 MPH.

Refer to Appendix A for typical sections.

3.3.3.1. (1) Right of Way - The table below represents the ROW acquisitions that will be required for this project. The proposed project will also require multiple Grading Releases throughout the corridor.

Exhibit 3.3.3.1 Right-of-Way Acquisitions				
Property Owner	Property Address	Tax Map No.	Type of Acquisition	Estimated Acquisition Area
109 S Union Street LLC	216 Monroe Ave	121.41-2-6	PE	48 sf.
109 S Union Street LLC	111 South Union Street	121.41-2-2	TE/PE	352 sf. / 810 sf.
Richard Winterroth & Carl Zizzo	68-70 North Union Street	106.82-3-30	PE	50 sf.
Christian Bethel Fellowship Church Rochester	321 East Ave	121.33-1-9.3	TE/PE	4,286 sf. / 2,749 sf.
Bethel Full Gospel Church	292 East Ave	121.25-1-42	PE	38 sf.
ESL Federal Credit Union	255 Chestnut St	121.0-21.002	TE	792 sf.
Margaret Woodbury Strong Museum	1 Manhattan Square Drive	121.33-1-5	TE/PE/FEE	22,261 sf. / 4,507 sf. / 1,384 sf.

3.3.3.1. (2) Curb – All new or improved roadways will include vertical face granite curbing per City of Rochester standards.

3.3.3.1. (3) Grades – The proposed grades will follow the existing topography of the corridor. Grades are typically less than 2%. The proposed Inner Loop ramps will require grades of approximately 4.25% to traverse back under the East Main Street Bridge and reconnect to the existing Inner Loop mainline elevations.

3.3.3.1. (4) Intersection Geometry and Conditions – Most of the proposed intersections will be constructed as typical 4-way urban intersections. The adjoining city streets typically intersect the corridor at right angles.

During the preliminary design all of the major intersections were evaluated for alternate intersection geometrics including roundabouts. A full discussion on the various intersections options evaluated can be found in the Intersection Alternative memorandum in Appendix G.

The Project Scoping Report depicted two roundabouts within the project corridor. Several factors during the preliminary design phase have resulted in the removal of these two roundabouts from further consideration as described below:

- The Howell Street / South Union Street roundabout was eliminated from further consideration due to several factors. The roundabout would remove approximately two blocks of parking within a residential section that is already experiencing significant parking deficiencies. These deficiencies are the result of an abundant number of multifamily buildings without off street parking amenities. To further complicate the demand, the adjoining dead end side streets have no alternate overflow parking access except along Union Street. The roundabout location (with medians) would also impact

access for the various dead end side streets and the residential parcels on the east side of Union Street, which are located within the limits of the roundabout and its approaches. For example, one of the driveway's, which provides access to a residential apartment building, would need to be incorporated into the roundabout. Lastly, the large roundabout footprint reduces the amount of developable lands. In summary, the roundabout conflicts with several of the project goals and objects identified in Section 1.2.3 and therefore; it was removed from further consideration.

- The Charlotte Street / Inner Loop Ramps / Union Street roundabout was also eliminated from further consideration. This roundabout originally was intended as a transition section from the local street network to the Inner Loop expressway. The original concept was feasible due to the northern section of North Union Street from Charlotte Street to East Main Street was one-way northbound. This one-way northbound operation allowed for a 4 leg roundabout to exist with the northbound exit splitting to the Inner loop and North Union Street. During the preliminary design phase, this section of one-way on Union Street was converted to two-way to improve area wide mobility. This resulted in the need for a 5 leg roundabout to accommodate all of the approaches. During the intersection evaluation process, alternate reconnection points were evaluated for the Inner Loop ramps. This resulted in the relocation of the ramps just south of the Richmond street intersection. The resulting Charlotte / Union and Inner Loop Ramps / Union intersections would operate without the need for signalization. Therefore the roundabout was eliminated from further consideration.

During the preliminary design phase, several intersection options were evaluated. Below is a summary of the preferred option.

Inner Loop / Monroe / Chestnut Intersection - Due to the removal of the Inner Loop mainline several alignment options were explored. Relocating the alignment to the northern or southern edge of the ROW corridor did not allow improvements to be made to the existing 43 degree skew angle of the intersecting roadways. A hybrid solution was determined to be the most effective where the western approach would favor the southern alignment and the eastern approach would favor the northern alignment. A large reverse curve would be utilized to connect the two alignments and improve the skew angle to 53 degrees. This approach provided several benefits including, providing ample room for the terminus of the cycle track on the NE corner, reduced pedestrian crossings movements and facilitated large vehicle turning movements. In addition this intersection had further complications due to existing property access located on the existing expressway ramp. To accommodate this existing access, a parallel one-way alley was created to separate the driveways and on-street parking from the expressway ramp terminus.

Howell / South Union Street Intersection – The removal of the Inner Loop mainline provided several options for the geometric orientation of this intersection. Several options were presented to the public during the public involvement process (see Appendix N). The option to provide an intersection aligned with Lafayette Park was determined to be the most beneficial. This intersection geometry provides for a single point intersection, facilitates turning movements, provides shorter pedestrian crossing distances, and provides suitable conditions for the cycle track operations.

Inner Loop Ramps / North Union Street Connection – The northern terminus for the Inner Loop will require ramps near the north end of the project. Several options were evaluated during the preliminary design phase. Below is a list of options evaluated:

- T Intersection with Charlotte Street – This option would provide a T-intersection connection with Charlotte Street mid-block between Pitkin Street and North Union Street. This option was deemed infeasible due to the limited segment length (160') that exists between these two streets. This limited space did not provide sufficient stacking distance at the Charlotte / North Union Street intersection and created excessive spatial requirements to accommodate large vehicle turning movements.
- Connection to Pitkin Street – This option would provide the ramp terminus near the Pitkin Street / Richmond Street intersection. This option was deemed not desirable due to the additional infrastructure required along Pitkin Street and Charlotte Street to accommodate the additional traffic and the large vehicle turning movements. The two-way conversion of Pitkin Street was also considered and deemed not desirable due to the requirement of adding additional traffic movements to the University / Pitkin / East Main Street intersection. In addition, this would promote traffic flow down the Pitkin alley (Charlotte to Broad) instead of connecting to the arterial street of Union Street.

- Connection to Union Street – This option would provide the ramp terminus near the North Union Street / Richmond Street intersection. This option was deemed the most desirable due to its connectivity to the arterial street and geometric constraints under the East Main Street Bridge. The intersection location is also desirable due to the traffic operations at this location would not require signalization.

3.3.3.1. (5) Roadside Elements:

- (a) Snow Storage, Sidewalks, Utility Strips, Bikeways, Bus Stops - there are no proposed changes other than replacement.
- (b) Driveways - the driveway aprons will be modified to comply with the City of Rochester current standards for design.
- (c) Clear Zone - The clear zone will be approximately 1.5 ft. wide and will be refined during final design.

3.3.3.2. Special Geometric Design Elements -

3.3.3.2. (1) Non-Standard Features –

A non-standard super elevation rate is proposed to be retained along Howell Street near the Union Street intersection. The existing non-standard curve (radius – 60 ft.) has been improved to meet the minimum design criteria (Radius – 250'). This curve is part of a speed transition area on a T-Intersection approach where reduced speeds will occur. Due to the limited curve length and close proximity to the intersection, inadequate room is available for super elevation transitions to occur to reach the standard value (4%). The retainage of the existing normal crown super elevation rate meets a 25 MPH design speed, which will be above the estimated operating speeds for this section of roadway.

Non-standard feature justification forms can be found in Appendix E.

3.3.3.2. (2) Non-Conforming Features –

The following non-conforming features have been identified:

The Inner Loop ramp termini require a radius (150ft.) and superelevation rate (4%), which are below the design speed standards, 231 ft., and 6% respectively. Per the Highway Design Manual Section 2.7.5.2.A, *“The ramp design speed does not apply to the ramp terminals”*. These two terminus curves occur in a speed transition area to a stop controlled intersection where reduced speeds will occur and provide a beneficial traffic calming effect between the expressway and local city street network. Due to the limited space available a larger radius cannot be achieved without creating a skewed intersection that is not desirable due to the pedestrian and bicycle facilities at the terminus intersection. Due to the close proximity to the intersection, inadequate room is available for super elevation transitions to occur to fully reach the standard value. The proposed section, meets a 15 MPH design speed that will be at the anticipated operating speeds for this section of intersection approach.

In addition, I-490 ramp termini require a superelevation rate (Normal Crown), which is below the design speed standard of 3.5%. Per the Highway Design Manual Section 2.7.5.2.A, *“The ramp design speed does not apply to the ramp terminals”*. These two terminus curves (radius = 1000') occur in a speed transition area to a signalized intersection where reduced speeds will occur and provide a beneficial traffic calming effect between the expressway and local city street network. Due to the limitations of the existing topography, buildings, sidewalks, intersecting street profiles, and close proximity to the intersection, there is inadequate length for super elevation transitions to occur in order to reach the standard value (3.5%). The proposed Normal Crown superelevation meets a 15 MPH design speed that will be at the anticipated operating speeds for this section of intersection approach.

It is anticipated that all remaining proposed improvements will be designed to meet current design standards. No additional Non-Conforming features are anticipated at this time.

3.3.3.3. Pavement and Shoulder –

A new full depth asphalt pavement section will be used throughout the project limits. The new asphalt concrete pavement structure consisting of 9.5" of new bituminous asphalt concrete will be placed on 12" of new subbase material. A geotextile fabric will be placed to inhibit the movement of fine soils into the subbase material. New underdrain will be placed along the new granite curbs to improve subsurface drainage.

3.3.3.4. Drainage Systems –

The existing drainage system improvements will be limited to catch basin replacements, and supplemental catch basin installations where needed, to provide adequate roadway drainage throughout the corridor. The existing Inner Loop drainage system will be abandoned and a section of the existing combined sewer along the Inner Loop from Broad Street to East Avenue will be relocated. In addition a 6" underdrain system with curb will be installed along the proposed curb line to enhance subsurface pavement drainage. Manhole frames and covers will also be replaced.

3.3.3.5. Geotechnical –

No special techniques or considerations are needed.

At this time, it is anticipated that rock will be encountered during the construction of this project. Soil Borings will be conducted during subsequent phases to determine existing bedrock elevations.

3.3.3.6. Structures –

Alternative 1 includes the removal of the depressed Inner Loop expressway. The corridor will then be raised to an elevation that matches the adjacent terrain, thereby eliminating the need to retain and maintain the existing roadway bridges at Monroe Avenue, Broad Street and East Avenue, as well as the steam pipe bridge. As part of the removal the upper 8 feet of the existing substructures will be removed, and the remainder will be abandoned below grade.

Alternative 1 also eliminates the need to retain and maintain the existing retaining walls that run along both sides of the Inner Loop expressway. It is assumed that the top portion of the retaining walls would be demolished and the remainder of the walls would be abandoned in place below grade.

There are no proposed bridges within the project limits.

3.3.3.7. Hydraulics of Bridges and Culverts –

There are no bridges over waterways or culverts within the project limits.

3.3.3.8. Guide Railing, Median Barriers and Impact Attenuators –

Alternative 1 eliminates the need for most of the existing guide rail and appurtenances that are present today. All guiderail that will be retained within the project limits, including bridge railing, will be evaluated during final design for conformance to design standards and replaced or repaired, if necessary.

3.3.3.9. Utilities –

Existing private utilities; electric, gas and cable TV will be impacted throughout the project corridor due to proposed roadway improvements. In order to facilitate their necessary relocations, coordination with those private utilities will continue during the Detailed Design Phase.

Public utilities; traffic signal communications, water and street lighting will be impacted throughout the project corridor due to the proposed roadway improvements.

In addition, all utilities within the project limits will be further evaluated during final design for conformance to design standards and replaced or repaired, if necessary.

3.3.3.10. Railroad Facilities –

There are no railroad facilities in the project limits.

3.3.4. Landscape and Environmental Enhancements –

Significant opportunity exists with the preferred alternative to enhance and increase the green space and landscaping as a part of the overall enhancement and aesthetic improvement efforts for this project. Detailed landscaping/streetscape plan will be developed during detailed design.

Refer to Chapter 4 for complete discussion.

3.3.4.1. Landscape Development and Other Aesthetics Improvements –

The landscaping will be provided for or replaced as a part of the overall enhancement and aesthetic improvement efforts for this project. Refer to Chapter 4 for a more detailed discussion.

3.3.4.2. Environmental Enhancements –

The project will incorporate “green infrastructure” wherever possible. Traditional concrete or asphalt features such as the cycle track and adjoining buffer strips have the potential to utilize pervious pavements or porous pavers. These treatments will be evaluated during the detailed design phase.

3.3.5. Miscellaneous

NYS Smart Growth Public Infrastructure Policy Act (SGPIPA)

Pursuant to ECL Article 6, this project is compliant with the New York State Smart Growth Public Infrastructure Policy Act (SGPIPA). The project is an improvement to an existing infrastructure. It is located in a municipal center and in an area designated for concentrated infill development consistent with an approved comprehensive land use plan. Environmental impacts are expected to be negligible, and resource preservation and/or protection of such features as air quality, surface and groundwater and historic and archeological resources are included. The project will also foster mix land uses on the lands freed-up by the removal of the Inner Loop expressway and will improve mobility for all users including motorists, pedestrians, bicyclists and transit operations.

To the extent practicable this project has met the relevant criteria as described in ECL § 6-0107. The Smart Growth Screening Tool was used to assess the project’s consistency and alignment with relevant Smart Growth criteria; the tool was completed by the City of Rochester for inclusion in the design approval document and reflects the current project scope. A copy of the Smart Growth form has been included in Appendix M.

CHAPTER 4 - SOCIAL, ECONOMIC and ENVIRONMENTAL CONDITIONS and CONSEQUENCES

4.1 Introduction

The purpose of this chapter is to identify and support the NEPA Class and SEQR Type determination.

4.1.1 Environmental Classification

4.1.1.1 NEPA Classification -

The Scoping Report suggested classifying this project as a Class III EA to start preliminary design. Subsequent environmental evaluations included within this Draft Design Report have concluded this project can be classified as a Class II Categorical Exclusion with documentation. This project therefore; is classified as a Class II action under United States Department of Transportation (USDOT) National Environmental Policy Act (NEPA) Regulations, 23 CFR 771. A NEPA checklist has been prepared and is included in Appendix C.

The lead agency for NEPA is the Federal Highway Administration (FHWA).

4.1.1.2 SEQR Classification -

The project is a SEQR Type I Action in accordance with 17 NYCRR Part 15 - Procedures for Implementation of State Environmental Quality Review Act. The City of Rochester, as the Lead Agency for SEQR, has requested that a Full Environmental Assessment Form be completed for this project to assist with their assessment of project impacts. Upon review, it has been determined that there will be no potential significant environmental impacts identified and a SEQRA Negative Declaration Determination has been filed in accordance with 17 NYCRR 15.10. See Appendix D for further information.

4.1.2 Coordination with Agencies

Project coordination has occurred with the following agencies:

- Federal Highway Administration
- New York State Department of Transportation
- New York State Department of Environmental Conservation
- New York State Historic Preservation Officer (SHPO)
- US Fish and Wildlife Service
- New York Natural Heritage Program
- City of Rochester
- Monroe County

4.2 Social

Executive Order (EO) 12898 Environmental Justice in Minority Populations requires federal agencies, departments, and their contractors to consider any potentially disproportionate human health or environmental risks their activities, policies, or programs may pose to minority or low-income populations. EO 13045 (Protection of Children from Environmental Health Risks and Safety Risks) requires federal agencies to identify and assess health risks and safety risks that may disproportionately affect children. As with EO 12898, HRSA and most federal lead agencies determine impacts to children as part of the NEPA compliance process. Agencies must ensure that its policies, programs, activities, and standards address disproportionate risks to children that results from environmental health risks or safety risks. This section discusses the proposed project's potential impacts to social and economic factors, and, evaluates the socioeconomic effects of the project alternatives.

There are two alternatives being considered. The feasible option involves removing the Inner Loop from South Clinton Avenue to Main Street and reconstructing the original street grid (new at-grade arterials, Howell Street and Union Street), thereby reconnecting the neighborhoods. Under the No Build Alternative, the basic infrastructure would be retained and maintenance and rehabilitation efforts would be performed by primarily the State, along with City forces, to extend the service life of the existing pavement, structures and adjoining service roads and intersections.

4.2.1 Land Use

The project area is located in a highly urbanized, city setting that is composed of a major transportation network surrounded primarily by commercial, governmental and institutional properties to the west and smaller businesses interspersed with residential housing to the east. The majority of the project area and individual land parcels has been developed for over 100 years. Access to the Inner Loop is facilitated through a series of ramps which connect to the adjacent city roadways that cross-cut the adjacent neighborhoods.

During the initial Inner Loop Improvement Study, various land use evaluations were undertaken for the reclaimed land in the corridor that would be created by the implementation of Alternative 1. This land recovery allows for future land use opportunities and the potential to physically and visually connect the Central Business District to the adjacent neighborhoods. The 2001 study identified opportunities for residential neighborhood extensions, commercial development, and open space, in the range of 9.4 acres of new land depending on the at-grade road alignment and width characteristics. Since then, various community initiatives have taken a serious look at desired land uses and densities, resulting in several recommendations surrounding the Southeast Loop area. The 2003 Center City Master Plan and the 2007 Downtown Charrette process helped to formulate a vision on the desired community characteristics that can be considered in this area, including the need to:

- *Create a major gateway at the east end of Main Street,*
- *Create new development sites for civic space, new development and parking,*
- *Create new infill development that complements the historic housing stock along South Union Street,*
- *Reconnect Monroe Avenue to downtown through the addition of continuous building frontages,*
- *Expand and improve Manhattan Square Park and create a major civic space in front of the Strong Museum,*
- *Extend Woodbury Boulevard to improve connections and new opportunities for infill development,*
- *Create new neighborhoods that provide a built-in-constituency for Manhattan Square Park and other downtown destinations.*

4.2.1.1 Demographics and Affected Population -

The proposed project is located within a potential Environmental Justice area in the City of Rochester as mapped by NYSDEC. The project is located within three census tracts: Tract 93.01, Tract 93.02 and Tract 94. The following table is based on U.S. Census Bureau information:

Population in the Census Tracts							
Census Tract	Total Population	White	African American	American Indian and Alaska Native	Asian	Native Hawaiian and Pacific Islander	Other
Tract 93.01	2,491	553	1,458	33	16	5	426
Tract 93.02	1,514	960	415	29	68	4	38
Tract 94	4,530	2,303	1,744	40	275	10	158

*2010 census data

The immediate environment is defined as the proposed project corridor. Land uses in the immediate environment include, residential, commercial retail, and vacant properties. The affected population includes those who reside, work or own property along the proposed project corridor, as well as those using the subject route for commuting, medical care, transporting goods or conducting business.

This project is compatible with the Community's comprehensive plans.

4.2.1.2 Comprehensive Plans and Zoning -

The project (Alternative 1), as proposed, is consistent with the Community's comprehensive plan. Any changing to future zoning requirements will be approved by the City.

4.2.2 Neighborhoods and Community Cohesion

4.2.2.1 Community Cohesion -

Neighborhood cohesion is a comprehensive term that refers to an aggregate quality of a neighborhood. It is a social attribute that indicates a higher-than-average sense of community, shared civic responsibility, social interaction within a limited geographic space and interdependence that serves an assimilating function or a number of other localized social purposes. The current Inner Loop expressway long ago severed connectivity between the Central Business District and adjacent neighborhoods.

Removing the Inner Loop and transforming it to a community-scaled urban boulevard will serve to reconnect these entities by allowing the original street grid system to be rebuilt (e.g. Charlotte Street) as well as conversion of South Union Street (the new at grade arterial) to two-way operation. This will allow significantly improved access to adjacent properties. The combination of improved local access, lower travel speeds, and new development can help to reconnect adjacent neighborhoods to the urban core. The quality of neighborhoods and lifestyles can be positively affected as a result of the elimination the Inner Loop. The new roadway network and elimination of the expressway system will allow for improved accessibility by pedestrian, bicycle and vehicles between neighborhoods, eliminating the isolation of these neighborhoods from the vibrant Center City.

4.2.2.2 Home and Business Relocations -

The proposed Alternative 1 does not require the displacement of residences or businesses and there would be no relocation impacts.

4.2.3 Social Groups Benefited or Harmed

Social groups may be defined in various ways including age, race, wealth, ethnicity, place of residence, occupation, and family status.

4.2.3.1 Elderly and/or Disabled Persons or Groups -

A review of US Census data for Monroe County indicates that there is no significant concentration of elderly or disabled persons in the project area. The existing highway separates the Central Business District from the adjacent neighborhoods. This project proposes to reconnect these neighborhoods and therefore will improve accessibility for all user groups.

4.2.3.2 Transit Dependent, Pedestrians, and Bicyclists -

The changes in the roadway network under Alternative 1 will make it easier for pedestrians and bicyclists to travel across the area as the physical impediment of the recessed expressway will be removed and replaced by an at-grade transportation network and reclaimed green space and area for development. A

dedicated bike path and new separate sidewalk network will be constructed on the western side of Union Street.

4.2.3.3 Low Income, Minority and Ethnic Groups (Environmental Justice) -

Executive Order 12898, Federal Actions to Address Environmental Justice in Minority Populations and Low-Income Populations, was signed by the President on February 11, 1994, and directs Federal agencies to take the appropriate and necessary steps to identify and address disproportionately high and adverse effects of Federal projects on the health or environment of minority and low-income populations to the greatest extent practical and permitted by law. Specific requirements for NEPA related activities associated with federal actions include:

- Programs or activities under an agencies control should not directly or indirectly use criteria, methods, or practices that discriminate on the basis of race, color, or national origin.
- Opportunities for community input must be provided.
- Environmental effects on minority communities and low-income communities must be analyzed and mitigation measures outlined wherever feasible.

The following table provides demographic and economic data for the 2010 census tracts, which comprise the project study area. This information is based on scientific and technical methodologies that do not discriminate either directly or indirectly on the basis or income, race, color, or national origin.

Minority Population in the Census Tracts and the City of Rochester						
Census Tract	Total Population	White	African American	Other	Total Minority	% Minority
Tract 93.01	2,491	553	1,458	480	1,938	77.8%
Tract 93.02	1,514	960	415	139	554	36.6%
Tract 94	4,530	2,303	1,744	483	2,227	49.2%
City of Rochester	210,565	91,951	87,897	30,717	118,614	56.3%

The guidance on evaluating Environmental Justice states that minority populations should be identified where either:

- The minority population of the affected area exceeds 50 percent; or
- The minority population percentage of the affected area is meaningfully greater than the minority population percentage in the general population or other appropriate unit of geographic analysis.

The data indicates that the percentage of the minority population within one census tract (93.01) exceeds the percentage of minority population city-wide. However, this census tract begins at East Main Street and includes the area on the north side of the northern portion of the Inner Loop as opposed to the southern portion of the Inner Loop that is impacted by this project. Therefore this area is located adjacent to but outside the area of construction.

The poverty information collected from the 2010 Census for census tracts 93.01, 93.02 and 94 is found below. In addition, city-wide poverty information is included for comparison purposes.

Low-Income Population in the Census Tracts and the City of Rochester			
Census Tract	Population*	Below Poverty Level	% Total
Tract 93.01	2,491	1,862	74.7%
Tract 93.02	1,514	562	37.1%
Tract 94	4,530	1,383	30.5%
City of Rochester	210,565	65,485	31.1%

*Population for whom poverty status is determined.

The data indicates that the percentage of the low-income population for all census tracts within the project area exceeds the percentage of low-income population city-wide.

Environmental justice issues require consideration to determine if the project would create disproportionately high environmental and health risks to this low-income and minority segment of the population. The project study area is identified as consisting of low-income and minority populations at a higher percentage when compared to the city as a whole.

However, the project is not expected to result in increased health risks to the affected community. Adverse environmental risks would be limited to short-term construction impacts including increased construction traffic, noise, vibration, and fugitive dust emissions. Construction activities would occur for a period of approximately 36 months. Standard measures to minimize adverse effects would be incorporated into the contract specifications. All work would be required to comply with local noise and traffic codes and ordinances. Truck traffic would be restricted from all local residential streets.

There are no identifiable long-term adverse impacts from the project, and it is not expected to increase risks to the affected community, including minority and low-income populations.

To insure proper public information and opportunities for comment by low-income and minority populations, a comprehensive public involvement program is on-going for the project. This program includes public meetings, presentations and adequate media coverage.

The City of Rochester is committed to Title VI of the Civil Rights Act which stipulates that no person in the United States shall on the grounds of race, color, or national origin, be: excluded from participation; denied the benefits of; or be subjected to discrimination under any program or activity receiving federal assistance.

4.2.4 School Districts, Recreational Areas, and Places of Worship

4.2.4.1 School Districts -

There will be no significant impacts to the local school district, except for the temporary disturbances and inconvenience generally associated with construction activities. Only one school facility, located at 200 University Avenue, is adjacent to the project corridor. This facility houses World of Inquiry School 58, serving grades K-7. Communication with the City of Rochester School District during construction will help to mitigate potential construction impacts.

4.2.4.2 Recreational Areas -

No negative impact to recreation areas are expected as a result of the project. Although there are a number of parks located within the City of Rochester, there is only one park in the immediate project corridor, Wadsworth Park. In the vicinity of Wadsworth Park, it appears that the project will actually be creating the opportunity for additional green space on the north side of the park with the removal of the Inner Loop. These improvements will be refined during the final design phase. Opportunities for additional green space are expected as part of the streetscape improvements associated with project improvements. Access for pedestrian traffic is expected to be improved with the implementation of this project.

Rochester's Strong Museum of Play is located adjacent to the corridor on the west side between Monroe Avenue and Broad Street at One Manhattan Square. This internationally acclaimed museum encompasses several acres of property and approximately 300,000 sq. ft. of buildings. This project will have no negative impacts to this parcel. This project will include improved streetscape features, additional green space at the intersection of Monroe-Chestnut and Howell, and introduce new property that will be reclaimed for re-development or establishment opposite from the Strong Museum main parking lot.

4.2.4.3 Places of Worship -

No negative impact to places of worship is expected as a result of the project. There are three (3) places of worship located along the corridor. These include:

- Bethel Christian Fellowship, 321 East Avenue
- New Hope Free Methodist Church, 62 North Union Street
- Word of the Cross, 76 North Union Street

4.3 Economic

The proposed project is located in the City of Rochester, New York which is a federally-designated Economically Distressed Area. This project (Alternative 1) will have a net positive impact on the long-term efficiency, reliability and cost competitiveness of the United States with respect to the movement of workers or goods. Removal of the Inner Loop Expressway will improve local accessibility in the heart of a major Central Business District that is home to 50,000 employees and hosts millions of visitors annually. The expressway is used for commuting purposes and its removal will not result in significant negative impacts to travel times.

The initial transportation investment will create an estimated 319 job years. However, unlike average transportation investments, this project will leverage significant private redevelopment that will create many more long term jobs in an economically-distressed inner city. The project will make improvements to the roadway infrastructure and circulation on the east side of Rochester's Central Business District, thus allowing for significant expansion, hiring, and growth of private sector businesses. Based on the Inner Loop East Reconstruction Market Analysis, dated July 2013, raising this portion of the Inner Loop will create development parcels that can accommodate between 428,000 and 795,000 square feet of mixed-use real estate development. The new development could support a total land value of all parcels between \$8.0 million and \$11.5 million. Over the long term, this transportation investment will generate considerable local employment growth through the redevelopment of acres of land freed up by removing this section of the Inner Loop.

Mixed use infill development containing retail, office, and residential space will lead to long-term economic gain in an inner city with above-average concentrations of minority and low-income populations. Economic competitiveness is demonstrated by the project's ability to increase the efficiency and effectiveness of the transportation system through integration or better use of all existing transportation infrastructure. The elimination of the expressway section allows for the reconnection of a grid roadway system that will improve overall connectivity and circulation in the area. This increased mobility includes not only vehicular traffic but also improved pedestrian and bicycle access and transit-supportive features. The project includes extending pedestrian links along all newly reconnected cross streets in addition to the new pedestrian systems along the new arterial/boulevard. Bicycle facilities, pedestrian amenities, and transit-supportive appurtenances will be provided where possible.

4.3.1 Regional and Local Economies

The project (Alternative 1) is intended to promote positive local economic impacts. These positive impacts include those that will result from the connectivity established between the surrounding neighborhoods which are now isolated from the Center City area. This project is consistent with the City of Rochester's Center City Master Plan, which recognizes the importance of economic development associated with this proposed boulevard style roadway to replace the below-grade roadway system.

Economic competitiveness is demonstrated by the project's ability to address the four major challenges being faced in the southeast Inner Loop area, they are:

- Overcome the barrier created by the underutilized Inner Loop;
- "Right-Size" wide streets that discourage pedestrian activity;
- Break up "superblocks" that impede pedestrian and vehicular connections; and
- Maximize development potential of vacant and underutilized land.

Removal of the expressway section under Alternative 1 allows for reconnecting the street grid system. This provides for the integration of livability in the transportation system. Some of the livability principles¹ that directly relate to this project include:

- *Provide more transportation choices.* Develop safe, reliable, and economical transportation choices to decrease household transportation costs, reduce dependence on foreign oil, improve air quality, reduce greenhouse gas emissions, and promote public health.
- *Enhance economic competitiveness.* Improve economic competitiveness through reliable and timely access to employment centers, educational opportunities, services, and other basic needs by workers, as well as expanded business access to markets.
- *Support existing communities.* Target Federal funding toward existing communities—through strategies like transit oriented, mixed-use development, and land recycling—to increase community revitalization and the efficiency of public works investments and safeguard rural landscapes.
- *Value communities and neighborhoods.* Enhance the unique characteristics of all communities by investing in healthy, safe, and walkable neighborhoods—rural, urban, or suburban.

4.3.2 Business Districts

4.3.2.1 Established Business Districts –

Because the Inner Loop is a limited access highway, there is essentially no established business district associated with the southeast section of the Inner Loop. Within the southeast area, connecting the East End District (west side of Inner Loop from Main Street to Broad Street), Upper East End District (east side of Inner Loop from University to north of Howell) and the Manhattan Square District (west side of Inner Loop from Broad Street to Monroe Ave) is essential, and removing the southeast section of the Inner Loop will make it possible. The Center City central business district and the business districts associated with East Main Street, Park Avenue, and Monroe Avenue areas are in close proximity to the project corridor. These districts consist of a mix of dense commercial, retail and service businesses.

4.3.2.2 Effects on Business Districts –

A positive impact to these business districts is expected due to the improved connectivity between the Center City area and these business districts, as well as the land use changes resulting from this project.

4.3.3 Specific Business Impacts

4.3.3.1 Established Businesses –

As the Inner Loop is a limited access highway, there are essentially no existing highway related businesses along the southeast section of the Inner Loop.

4.3.3.2 Effects Assessment -

Businesses in the surrounding blocks along South Union and Pitkin Street may experience positive effects under Alternative 1 as a result of:

- Improved local circulation and access with the conversion of one-way to two-way streets;
- Improved local circulation with the reconnection of the street grid system;
- Direct connection to adjacent residential neighborhoods;
- New developments will increase population density in the area needing more services;
- Increased pedestrian, bicycle and vehicular traffic along the new accessible urban boulevard; and,
- Opportunity for revitalization of existing building frontages and space.

Minor and temporary inconveniences may be experienced during the construction phase of the project, but no notable permanent impact to highway related businesses is expected as a result of this project.

4.4 Environmental

4.4.1 Wetlands

4.4.1.1 State Freshwater Wetlands -

There are no NYSDEC regulated freshwater wetlands or regulated adjacent areas (100ft) within the project area, as per the NYSDEC Freshwater Wetlands Maps for Monroe County. A site visit was performed to verify this. No further investigation is required and Environmental Conservation Law, Article 24 is satisfied.

4.4.1.2 State Tidal Wetlands -

A review of the NYSDEC GIS wetland data files indicates that there are no NYSDEC jurisdictional tidal wetlands or regulated adjacent areas within or near the project limits, and ECL Article 25 does not apply.

4.4.1.3 Federal Jurisdiction Wetlands -

The project site has been reviewed for wetlands in accordance with the criteria defined in the 1987 US Army Corps of Engineers Wetland Delineation Manual. It has been determined the project will not impact areas that meet this criteria.

A Section 401 Water Quality Certification is not required for the proposed project, since it does not involve work within the waters of the United States, including wetlands (Section 10 or Section 404).

4.4.1.4 Executive Order 11990 -

Based on a site visit, there are no wetlands located within the project's area of potential effect. Executive Order 11990 does not apply to this project.

4.4.1.5 Mitigation Summary -

No wetland mitigation/monitoring plan is required for this project, since no wetlands will be impacted.

4.4.2 Surface Waterbodies and Watercourses

4.4.2.1 Surface Waters -

The project activities do not involve excavation in or the discharge of dredged or fill material into Waters of the U.S. No permits under this Section are anticipated.

4.4.2.2 Surface Water Classification and Standards -

Based upon a review of the NYSDEC GIS data maps for regulated streams, there are no surface waterways within the proposed project limits. The Genesee River is the major surface water body situated in the project vicinity but is located approximately 800 feet west of the project area but will not be impacted by the proposed project. The NYSDEC stream classification for the Genesee River in the project vicinity, as contained in 6 NYCRR, Chapter X, is Class B Fresh Surface Waters and the water quality standard for the river is B. The best use of Class B waters are primary and secondary recreation contact and fishing. The waters are also suitable for fish propagation and survival.

4.4.2.3 Stream Bed and Bank Protection -

Based upon a review of the NYSDEC GIS database, and as verified by a site visit, there are no protected streams, nor 50-foot regulated stream banks (on either side of a regulated stream) in the project area.

4.4.2.4 Airport and Airway Improvement -

There are no airports near the project corridor. As such, there will be no involvement with either airports or airways associated with this project.

4.4.2.5 Mitigation Summary -

Neither the Null alternative nor Alternative 1 will result in impacts that warrant mitigation.

4.4.3 Wild, Scenic, and Recreational Rivers

4.4.3.1 State Wild, Scenic and Recreational Rivers -

There are no NYSDEC Designated, Study or Inventory State Wild, Scenic or Recreational Rivers within or adjacent to the proposed project site. No further review is required.

4.4.3.2 National Wild and Scenic Rivers -

The project does not involve a National Wild and Scenic River as shown by the Nationwide Rivers Inventory List of National Wild and Scenic Rivers. No further review is required.

4.4.3.3 Wildlife/Waterfowl Refuge Section 4(f) Involvement -

The proposed project does not involve work within or adjacent to a wildlife or waterfowl refuge. No further Section 4(f) consideration is required.

4.4.3.4 Mitigation Summary -

Neither the Null alternative nor Alternative 1 will result in impacts that warrant mitigation.

4.4.4 Navigable Waters

4.4.4.1 State Regulated Waters -

There are no state regulated navigable waters located within the project area.

4.4.4.2 Office of General Services Lands and Navigable Waters -

There are no OGS underwater holdings located within the project area, nor are there any navigable waters present.

4.4.4.3 Rivers and Harbors Act – Section 9 -

Since the project does not involve the construction or modification of any bridge, dam, dike, or causeway over any navigable water of the United States, Section 9 is not applicable.

4.4.4.4 Rivers and Harbors Act – Section 10 -

Since the project does not involve the creation of any obstruction to the navigable capacity of any of the waters of the United States, or in any manner alter or modify the course, location, condition, or capacity of any navigable water of the United States, Section 10 is not applicable.

4.4.5 Floodplains

As shown of the GIS database for the 100 year floodplains, there are no floodplains mapped in the project area as identified by a review of FEMA Firm Panel 0213G, number 360431, map number 36055C0213G for the Rochester, New York area in the vicinity of the project. The closest floodplains are those associated with the Genesee River.

4.4.5.1 State Flood Insurance Compliance Program -

As shown on the GIS data base for the 100 year floodplains, there are no regulated floodplains within the project area.

4.4.5.2 Executive Order 11988 -

The project will not impact any floodplains. EO 11988 does not apply.

4.4.6 Coastal Resources

4.4.6.1 State Coastal Zone Management Program -

The proposed project is not located in a State Coastal Zone Management (CZM) area, according to the Coastal Zone Area Map from the NYS Department of State's Coastal Zone Management Unit.

4.4.6.2 State Coastal Erosion Hazard Area -

The proposed project is not located in or near a Coastal Erosion Hazard Area.

4.4.6.3 Waterfront Revitalization and Coastal Resources Program -

According to New York State Department of State, Office of Communities and Waterfronts "List of Approved Coastal Local Waterfront Revitalization Programs (LWRPs)", the City of Rochester plan was originally approved in 1990, and subsequently amended on December 15th, 2011 to include a development plan for the Port of Rochester site. The City of Rochester also identifies a Critical Environmental Area for actions proposed within 100 feet of the Genesee River. However, this project is outside the limits of both the LWRP and the CEA. As a result, no further action is required.

4.4.6.4 Federal Coastal Barrier Resources Act (CBRA) and Coastal Barrier Improvement Act (CBIA) -

The proposed project is not located in, or near a coastal area under the jurisdiction of the Coastal Barrier Resources Act (CBRA) or the Coastal Barrier Improvement Act (CBIA).

4.4.7 Groundwater Resources, Aquifers, and Reservoirs

4.4.7.1 Aquifers -Topics may include, but are not limited to:

The proposed project area is not situated over a New York State Department of Environmental Conservation (NYSDEC) Primary or Principal aquifer as identified in Kantrowitz and Snavely (1982). Supplemental groundwater investigations will, therefore, not be required for the project.

4.4.7.2 Drinking Water Supply Wells (Public and Private Wells) and Reservoirs -

There are no municipal drinking water wells, wellhead influence zones, or reservoirs within or near the project area, according to the *NYS Atlas of Community Water System Sources*, dated 1982, issued by the NYS Department of Health.

4.4.8 Stormwater Management

Although the project will cause ground disturbance that exceeds 1 acre, stormwater runoff from the entire corridor watershed does not discharge to any Waters of the United States. Therefore the project does not require coverage under NYSDEC SPDES General Permit GP 0-10-001.

Stormwater runoff is collected and conveyed to surface drains that directly discharge to a combined sewer system. The combined flow eventually discharges to a sewage treatment facility for water quality treatment.

The project will also utilize “green infrastructure” features to reduce existing surface runoff wherever feasible.

As is typical for most projects, Erosion and Sediment Control Plans and Details will be developed during Final Design in accordance with Section 209 Soil Erosion and Sediment Control of the NYSDOT Standard Specifications. Design plans will include both temporary and permanent measures to prevent soil erosion and sedimentation.

4.4.9 General Ecology and Wildlife Resources

4.4.9.1 Fish, Wildlife, and Waterfowl -

A review of State and Federal mapping and a walkover of the project area indicate that there are no special habitat areas for fish, wildlife or waterfowl.

4.4.9.2 Habitat Areas, Wildlife Refuges, and Wildfowl Refuges -

The proposed project does not involve work in, or adjacent to, a wildlife or waterfowl refuge. No further consideration is required. In addition, a review of the projects area of potential effect indicates that there is not any special habitat or breeding areas present.

4.4.9.3 Endangered and Threatened Species -

New York State Department of Environmental Conservation, Division of Fish, Wildlife and Marine Resources, New York Natural Heritage Program, indicates the project has no record of rare or state-listed animals or plants, or significant natural communities within the vicinity of the project site.

A review of the United States Fish and Wildlife Service (USFWS) website indicates that there are three federally listed, delisted, or proposed endangered or threatened species located within Monroe County:

- Bog Turtle *Clemmys muhlenbergii* – Threatened

A habitat assessment for the Bog Turtle revealed that there is neither, a suitable habitat present, nor visible sign of activities by the turtle within the project action area. Therefore the project will result in no effect to the species or species habitat.

- Northern Long-Eared Bat (*Myotis septentrionalis*) – Endangered

A habitat assessment for the Northern Long-Eared Bat revealed that there is neither, a suitable habitat present, nor visible sign of activities by the bat within the project action area. Therefore the project will result in no effect to the species or species habitat.

- Bald eagle (*Haliaeetus leucocephalus*) - Delisted

The Bald Eagle was delisted on August 8, 2007. While there are no Endangered Species Act ESA requirements for Bald Eagles after this date, the eagles continue to receive protection under the Bald and Golden Eagle Protection Act (BGEPA). A habitat assessment for the Bald eagle revealed that there is neither, a suitable habitat present nor visible signs of nesting activities within the project action area. Therefore the project will result in no effect to the species or species habitat.

Copies of all correspondence can be found in Appendix O.

4.4.9.4 Invasive Species -

This project is located within an urbanized roadway corridor with no natural adjacent areas or parks. A review of the existing corridor did not indicate any significant presence of known invasive species within the right-of-way.

4.4.9.5 Roadside Vegetation Management -

There is no wildlife-supporting vegetation present along the project corridor.

4.4.10 Critical Environmental Areas

4.4.10.1 State Critical Environmental Areas -

According to information obtained from the NYSDEC website, critical environmental areas (CEAs) in the vicinity of the project include land within 100 feet of the Genesee River and areas zoned by the City of Rochester as “open space – O-S”. The open space district has been established to preserve and enhance Rochester’s open spaces and recreational areas by protecting these natural resources and restricting development that does not respect these environmentally sensitive areas. Open space districts apply to all publically owned parks, squares, recreational areas, natural wildlife areas, waterfront and cemeteries.

The Genesee River is located beyond the project area. However, Wadsworth Park, a small passive recreation area that is composed primarily of open lawn, is designated by the City of Rochester as open space and is located immediately adjacent to the proposed roadway corridor. However, the project will not acquire nor impact any property from this parcel. Any changes will be restricted to new curb lines, sidewalk and signage. Therefore, it has been determined that the project does not significantly, adversely affect this CEA and no further investigation is required.

4.4.10.2 State Forest Preserve Lands -

According to information obtained from NYSDEC, the proposed project does not involve work in or near state forest preserve lands.

4.4.11 Historic and Cultural Resources

4.4.11.1 National Heritage Areas Program -

There are no "National Heritage Areas" within or in the vicinity of the project area.

4.4.11.2 National Historic Preservation Act – Section 106 / State Historic Preservation Act – Section 14.09 -

Because the project is a federally funded action, involves a federal permit, or is state funded with the possibility of becoming federally funded, the Department will be following the Section 106 Process of the National Historic Preservation Act. This ensures compliance with the NYSHPA Section 14.09 process.

Three *Cultural Resources Reconnaissance Survey Reports* were completed under PIN 4940.T7 for the Inner Loop East Reconstruction Project:

- *Inner Loop East Reconstruction Project Phase 1A Cultural Resource Survey* prepared by Nathan Monatgue, M.A., James Hartner RPA., and Douglas J. Perrelli, PhD., RPA, Department of Anthropology, State University of New York at Buffalo, February 2013.
- *Inner Loop East Reconstruction Project Phase 1B Archaeological and Architectural Reconnaissance Survey* prepared by Nathan Monatgue, M.A. and Douglas J. Perrelli, PhD., RPA, Department of Anthropology, State University of New York at Buffalo, May 2013.
- *Phase 2 Archaeological Site Examination of the Amos Burrow site and George Crouch site-Inner Loop East Reconstruction Project* prepared by Ryan F. Austin, PhD., RPA, Nathan Monatgue, M.A. and Douglas J. Perrelli, PhD., RPA, Department of Anthropology, State University of New York at Buffalo, January 2014.

The Phase 1 reports inventoried all structures and field tested for archeological concerns within the Area of Potential Effect (APE) for the project sites. Three (3) National Registered Listed properties, four (4) National Registered Eligible, two (2) National Registered Eligible Historic Districts; and two (2) archeological resources were identified.

The Phase 2 report determined that one of the two potential archeological sites, the Amos Burrows site, was National Register eligible.

The Department made a determination of "*No Adverse Effect*" based on a Finding Document in accordance with 36 CFR Part 800. The Findings Document Package and effect determination were submitted to the SHPO for their concurrence on January 30, 2014.

In a letter dated February 26, 2014 the SHPO did not concur with the "*No Adverse Effect*" opinion and issued an "*Adverse Effect*" finding for the project. The SHPO determined that the Amos Burrows Site meets the requirements of National Register eligibility and the archaeological excavations completed on the site as part of the Phase 2 archaeological assessment were significant enough to constitute an "*Adverse Effect*" to the eligible resource due to extensive disturbance to those intact portions of the site. The SHPO did concur that no further archaeological excavation is warranted for the NR-eligible site.

FHWA will make the final *Adverse Effect* determination and will notify the Advisory Council on Historic Preservation (ACHP). The ACHP has 15 days to from receipt to participate in the Section 106 process.

Correspondence with SHPO, FHWA, along with the Finding Document, is included in Appendix O.

4.4.11.3 Architectural Resources -

Property listed on, or eligible for, inclusion in the National Register of Historic Places is located within the project's Area of Potential Effect (APE).

The three (3) properties identified as potential direct impacts were NR-eligible based on the structure significance (Criterion C – Design or Construction Value) and not the property. These properties are not listed as being located within a historic district. The three (3) properties include:

- 62 North Union Street
- 68 South Union Street
- 84 South Union Street

For all of the above properties, proposed improvements are limited to pavement and sidewalk reconstruction. Sidewalk improvements will be at the same line and grade of the existing walks. The proposed curb replacement will be relocated approximately 4' farther from the property line to accommodate a 5' wide tree lawn along the property frontage. This tree lawn reestablishes the original street setting prior to the expressway construction. No impact will occur to these buildings.

4.4.11.4 Archaeological Resources -

Property listed on, or eligible for, inclusion in the National Register of Historic Places is located within the project's Area of Potential Effect (APE).

The Phase 1A Report recommended subsurface testing due to the analysis of historic maps and textual evidence that suggests the historic sensitivity is high for in the project area, especially in those areas around historic buildings and locations.

The Phase 1B archaeological survey identified no pre-historic sites and two potentially National Register Eligible sites:

- The George Crouch site
- The Amos Burrows site

The report recommended further testing to determine National Register eligibility if they cannot be avoided; and due to the anticipated vertical disturbance extending into the intact archeological deposits.

The Phase 2 Archaeological Site Exam was conducted for the two potentially National Register-eligible sites due to the preferred design alternative that has the potential to disturb intact archeological deposits. The results of the investigation concluded that only the Amos Burrows site was National Register eligible under Criterion D, based on the information provided by the historic mid-to-late 19th and early 20th century cultural deposits.

The SHPO determined that the Amos Burrows Site meets the requirements of National Register eligibility letter dated February 26, 2014 and the archaeological excavations completed on the site as part of the Phase 2 archaeological assessment were significant enough to constitute an "*Adverse Effect*" to the eligible resource due to extensive disturbance to those intact portions of the site. The SHPO recommended and FHWA determined that no further archaeological excavation is warranted for the site and that the NYSDOT could proceed to the development of a Memorandum of Agreement (MOA) for the "*Adverse Effect*".

A Memorandum of Agreement has been developed between the Federal Highway Administration, the NYS Historic Preservation Officer, the NYS Department of Transportation and the City of Rochester for mitigation of the “*Adverse Effect*”.

Stipulations required by the SHPO to be included in the MOA are:

- Content of the MOA should clearly document the adverse effects to the NR-eligible site;
- Provide for archaeological monitoring of the site during construction;
- Address the need for curation of the artifacts recovered from the NR-eligible site;
- Mitigation of the adverse effects through an interpretive panel/kiosk at the site location.

A copy of the MOA and correspondence can be found in Appendix O and Appendix P.

4.4.11.5 Historic Bridges -

There are no bridges over 50 years old or listed on NYSDOT’s Historic Bridge Inventory that are located within the project’s area of potential effect.

4.4.11.6 Historic Parkways -

This project does not have the potential to impact any Historic Parkways.

4.4.11.7 Native American Involvement -

The proposed project does not lie within Federal, Tribal, or Indian-owned property. The Archaeological Resources Protection Act of 1979 does not apply. Furthermore, conformance with this Act is covered in the Section 106 Process.

4.4.11.8 Section 4(f) Involvement -

A Section 4(f) evaluation is not required as there is no proposed use to any resource protected under Section 4(f).

4.4.12 Parks and Recreational Resources

4.4.12.1 State Heritage Area Program -

The proposed project will not impact areas identified as State Heritage Areas.

4.4.12.2 National Heritage Areas Program –

The proposed project is located in Erie Canal National Heritage Corridor. Due to the significance of the Erie Canal to the City of Rochester’s development, the corridor incorporates all of the City of Rochester although the canal does not run through the project corridor. The proposed improvements will have a positive impact on the recreational or historic resources provided by the National heritage Corridor by expanding pedestrian and bicycle facilities and mobility through the project corridor.

4.4.12.3 National Registry of Natural Landmarks -

There are no listed nationally significant natural areas within, or adjacent to, the project area.

4.4.12.4 Section 4(f) Involvement –

The proposed project is located adjacent to Wadsworth Park. However, the project will not affect or require direct or indirect “use” of the park and a Section 4(f) evaluation is not required.

4.4.12.5 Section 6(f) Involvement -

The project does not impact parklands or facilities that have been partially or fully federally funded through the Land and Water Conservation Act. No further consideration under Section 6(f) is required.

4.4.12.6 Section 1010 Involvement -

The project does not involve the use of land from a park to which the Urban Park and Recreation Recovery program funds have been applied.

4.4.13 Visual Resources

4.4.13.1 Introduction –

The current Inner Loop expressway long ago severed connectivity between the Central Business District and adjacent eastern neighborhoods. Many structures were demolished to make way for the route, which was constructed in densely populated neighborhoods that surrounded downtown. The southeast section of the Inner Loop is a four to six lane divided expressway with parallel two to three lane frontage roads. This results in a facility that in some places has as many as twelve travel lanes and occupies a width ranging from 182 feet to 355 feet (curb to curb). The width of the roadway system is not the only negative visual aspect; the expressway is depressed (below grade) in relation to the service roads, creating a moat effect between the Center City and adjacent neighborhoods. The expressway does meet at grade with the service roads near the South Union Street exit. There are high retaining walls, bridges and overhead sign structures with very little landscaping/green space.

The visual environment can be reviewed by looking first at the ‘view shed’ areas within the corridor and then analyzing the view shed relative to the viewer groups (residents, pedestrians/bicyclists and visitors) and the viewer sensitivity. Some of the photos below show view sheds from a pedestrian/bicyclist crossing a bridge or residents/employees in adjacent buildings.



Combining the width and depth of the expressway system with the adjoining service roads, results in poor view sheds that are intimidating and uninviting from a non-motorized user.



A detailed visual resource assessment has been performed and is included in Appendix I.

4.4.13.2 Effects Assessment –

The transformation of the limited access expressway to an urban scale city street that will consist of 3-4 travel lanes, landscaped medians, roundabouts, a new reconnected street grid system, increased development density and the addition of pedestrian friendly amenities will notably improve the view sheds of this corridor.

4.4.14 Farmlands

4.4.14.1 State Farmland and Agricultural Districts -

Based on a review of the NYS Agricultural District Maps from Monroe County, the proposed project is not located in or adjacent to an Agricultural District.

4.4.14.2 Federal Prime and Unique Farmland -

The proposed project activities will not convert any prime or unique farmland, or farmland of state or local importance, as defined by the USDA Natural Resources Conservation Service, to a nonagricultural use.

4.4.15 Air Quality

An Air Quality Analysis Report was performed to determine the effect of the proposed design alternative on transportation related pollutant emissions within the study area of the reconstruction project. For this project, a conformity review, a mesoscale analysis and a microscale analysis screening were performed to satisfy the requirements of the National Environmental Protection Act (NEPA), the State Environmental Quality Review Act (SEQRA), and the Clean Air Act Amendment 1990 (CAAA90). The methodology conformed to NYSDOT's The Environmental Manual (TEM) 2010 which, for the Air Quality Section, currently adheres to the Environmental Procedures Manual (EPM), Section 1.1.

Conformity Review:

The proposed project is located in Monroe County, which is part of the Genesee Transportation Council (GTC). GTC is the designated Metropolitan Planning Organization (MPO) in the Genesee-Finger Lakes Region. The USEPA has designated Monroe County as in attainment for all applicable transportation related priority pollutants. Therefore, the region is not currently subject to conformity procedures per Section 176 of the CAAA90 and 40 CFR Parts 51 and 93; the GTC is not currently required to perform air quality analysis for the Region; and a conformity determination is not required for this project.

Mesoscale Analysis:

A mesoscale analysis was performed for this project. The results of a mesoscale analysis are relative and do not directly indicate that emissions in the study area are expected to be above regulatory thresholds. The mesoscale analysis is used to compare alternatives and as a screening tool to identify individual pollutants that may require additional study. The mesoscale analysis was performed for five indicator pollutants under years 2015, 2025, and 2035 for both the No-Build and Build alternatives. The emission factors for the analysis were determined from the MOVES (Motor Vehicle Emission Simulator) 2010b computer model, which is currently the approved emission factor model.

The results of the mesoscale analysis indicated that the emissions burdens for all five pollutants are expected to increase within the project area if the Build Alternative is constructed. Pollutant increases predicted under the Build Alternative ranged from 4% to 27% for all years. However, for this project it should be noted that, percent changes were inflated due to the limited study area. This project is expected to affect only the immediate area of the project corridor and not the surrounding roadway network. The effect of a limited study area can yield inflated percent changes for a mesoscale analysis since there is no dilution of the project's effects from the surrounding roadways with minor changes.

The higher pollutant emission rates for the Build Alternative are due to the conversion of a limited access roadway with consistent free-flow speeds averaging 50 mph to a full access roadway with 30 mph signal controlled stop-and-go traffic. Generally, the changes represented by this project will slow traffic along this corridor to speeds similar to that of other City streets within the surrounding roadway network such as Monroe Avenue, East Avenue, and East Main Street. Therefore, regardless of the percent increase in emissions from the downgrade of this freeway to a City street, future emissions along the proposed corridor would likely be similar to the expected background emissions found on other comparable volume streets present in this area of the City.

There is no EPM specified mesoscale percentage level change that would indicate that these pollutants would require further study or documentation; however, the general rule of thumb is an increase of more than 10% for the build alternatives. Since the maximum percentage increases for these pollutants is more than 10% for four of the pollutants, these percentage increases were further screened and documented in the design approval document. Further screening of the project was performed to indicate whether additional study in the form of microscale or hot-spot analyses would be appropriate.

Microscale Analysis Screening:

A microscale screening indicated that microscale analysis is not warranted and therefore, the proposed project is not expected to have significant air-quality impacts. The microscale screening of the corridor indicated that the overall volumes and the heavy vehicle volumes along the corridor are too low (below the thresholds) to warrant an in-depth microscale analysis for the indicator compounds carbon monoxide (CO) or particulate matter (PM). Therefore, in accordance with the EPM guidance, the screening indicates that a violation of the NAAQS regulatory thresholds is considered “extremely unlikely” for CO and PM and no further study is warranted. Additionally, due to the mandatory reduction of lead in gasoline, the FHWA has advised that a microscale lead analysis for highway projects is not needed or warranted.

Construction Air Quality:

Construction related air quality screening has indicated that no detailed analysis will be required for this project. Although air quality within the project corridor and the immediate vicinity will experience impacts during the construction period, the use of abatement measures for dust control and proper vehicle maintenance should lessen the severity of these impacts.

See Appendix K for further information.

4.4.16 Energy and Greenhouse Gas

This project has been reviewed to determine the need for a “Project Level” energy of greenhouse gas (GHG) analyses in accordance with the “Draft Energy Analysis Guidelines for Project Level Analysis”, NYSDOT November 25, 2003. This Draft Energy Analysis document refers to NYSDOT’s Energy Analysis Guidelines for TIPs and Plans (also dated November 25, 2003) which contains the guidance for determining regional significance. The criteria for determining whether project requires a quantitative Energy of GHG Analyses are generally: regional significance, significant increase in VMT, construction costs, projects identified through the scoping process, nature of the project, or existing problems in energy supply or distribution. This project comes close to one of the regional significance thresholds in that it is considered “new construction on a new alignment”; however, the threshold is for projects with new alignment of 1 mile or longer and the new alignment length for the proposed project is closer to 0.8 miles long. Therefore, this project does not require quantitative “Project Level” energy of GHG analyses per the NYSDOT guidance.

4.4.17 Noise

A Noise Analysis was performed to determine the effect of the proposed design alternative on transportation related noise impacts within the study area of the reconstruction project. The methods used

in this analysis are in accordance with the provisions and procedures of the policies stated in the federal noise regulations (23 CFR 772), and NYSDOT's *The Environmental Manual* (TEM). The Inner Loop project is classified as a 23 CFR 772 Noise Type I project which requires a noise analysis to determine whether noise abatement measures need to be considered.

To determine the effect that the Inner Loop project would have on existing noise levels and to determine what impact the noise would have on current land-use activities, nine noise sensitive receiver sites were selected for evaluation within the study area. At each receiver location, existing and future noise levels were obtained using field noise measurements and computer modeling. The results of the computer modeling were compared to FHWA standards for the identification of predicted future noise impacts.

FHWA Noise Activity Criteria (NAC) noise impacts were predicted at five of the nine receiver locations for the Build Alternative and four of the nine receiver locations for the No-Build Alternative. It should be noted that the term NAC noise impact is not intended to be used for the purpose of determining a "significant" noise impact under National Environmental Protection Act (NEPA) or the State Environmental Quality Review Act (SEQRA). A NAC impact is a noise level that approaches or exceeds a certain noise threshold that triggers the consideration of noise abatement measures.

With respect to an overall comparison between the No-Build and Build alternatives, the variation in the results ranged from 0-2 dBA for all receivers and 0-1 dBA for the five impacted receivers. Since 3 dBA is generally considered the minimum decibel difference noticeable to the human ear, the differences in noise levels between the No-Build and Build alternatives for the analyzed areas are essentially negligible and primarily imperceptible to the human ear. Therefore, consideration of the noise level differences between the No-Build and Build alternatives to favor one alternative over another is not recommended.

Due to factors external to the proposed project, future NAC noise impacts are expected at four of the nine receiver locations regardless of whether the proposed project is constructed. Given that the differences in the predicted noise levels between the Build and No-Build alternatives are projected to be imperceptible to the human ear at all five of the impacted receivers, it is not expected that this project will have a significant impact on noise levels throughout the corridor.

When noise impacts are predicted for a project, noise abatement must be considered for each impact; no favor is given to the higher decibel level impacts or different types of noise impacts (e.g. above NAC, substantial, severe) and all noise impacts must be considered equally for consideration of noise abatement. Therefore, noise abatement measures were considered along the project corridor for the areas represented by the five receiver locations that exhibited FHWA noise impacts. When noise abatement measures are being considered, 23 CFR 772 requires that every reasonable effort shall be made to obtain substantial noise reductions. A "substantial" noise reduction is defined as a reduction in the order of ten dBA. However, the abatement must provide a minimum reduction of at least seven dBA at the properties with the greatest reductions. In addition, noise abatement measures must be economically reasonable when compared to the number of residences benefitted. A benefitted residence is any residence where the noise level is reduced by 5 dBA or more by implementation of the noise abatement measure(s).

For the impacted areas, all noise abatement measures listed in 23 CFR Part 772.13(c) were examined and evaluated for reducing the dBA level. In all instances, the noise abatement measures were considered physically infeasible, economically unreasonable, or undesirable to the affected residents. Therefore, no noise abatement measures are recommended for this corridor.

See Appendix L for further information.

4.4.18 Asbestos

An asbestos assessment was performed to determine whether asbestos containing materials (ACMs) are expected to be disturbed as a result of this project. The results of this assessment included a review of the four bridges within the corridor to be impacted by the project, the expressway retaining walls, sidewalks, and associated railings and signs.

ACMs and suspect ACMs were identified within the record plans reviewed for this assessment. These suspect materials include:

BIN 1021630 – Monroe Avenue over Inner Loop

This structure was renovated in 2000 with the deck being replaced and the abutments rehabbed. The following materials were identified as suspect ACM from the original record plans and may still be present on the Bridge but their presence could not be verified in the field during the most recent inspection.

- Bituminous material (Item 61 – applied to the backs of all abutments and walls above tops of footings).
- Compressed asbestos sheet packing (located on top of the back walls).
- Pre-moulded bituminous joint filler and expansion joint materials – various locations including between abutment and approach walls (material was sampled see below).
- Twelve (12) – 5½” ducts for Rochester Telephone Corporation and twenty-four (24) RG&E 5½” conduits (conduits appear to have all been replaced with galvanized steel).

BIN 1050149 - Broad Street Bridge

- Bituminous material (Item 61 – applied to the backs of all abutments and walls above tops of footings).
- Compressed asbestos sheet packing (located on top of the back walls).
- Pre-moulded bituminous joint filler and expansion joint materials – various locations.
- Nine (9) - 4” asbestos cement ducts for Rochester Telephone Corporation.

BIN 1035240 - East Avenue Bridge

- Bituminous material (Item 61 – applied to the backs of all abutments and walls above tops of footings).
- Compressed asbestos sheet packing (located on top of the back walls).
- Pre-molded bituminous joint filler and expansion joint materials – various locations.
- Six (6) - 4” asbestos cement ducts for Rochester Telephone Corporation.

Inner Loop Retaining Walls

Pre-molded bituminous joint filler and bituminous material are also associated with the joint sections of the Inner Loop retaining walls located between South Clinton and East Main Street.

Utilities

A note was identified on the drawings which indicated that the RG&E electrical system in the area was historically composed of ACM transite duct. New electrical conduits installed at later dates were to be composed of galvanized wrought iron or steel pipe. Lighting standard conduits were composed of either fiber conduit or galvanized steel. However, the lighting duct materials used in the vicinity of the Monroe Avenue Bridge for the lighting poles are reportedly composed of 2-inch ACM transite conduit.

Traffic signal conduits are composed of galvanized steel. Storm sewers appear to have been constructed of concrete manholes and pipes, reinforced concrete cylinder pipe, vitreous clay pipe drops, and perforated corrugated metal pipe. Water mains and laterals appear to have been constructed of cast iron or steel pipe. The composition of the conduits associated with the other utilities in this area of the corridor could not be determined from the record plan drawings.

Field Inspection, Sampling and Identification

The inspection of the three bridges, expressway retaining walls, railings and sidewalks identified a number of known or suspect materials that were sampled for laboratory analysis or assumed to be

positive for asbestos. The following materials were analyzed by the laboratory. **Materials determined to be positive for asbestos are shown in bold.**

BIN 1021630 – Monroe Avenue over Inner Loop

- Black pre-molded bituminous joint filler found within between sections of the retaining walls and where the retaining walls meet the bridge abutments and piers.
- Green paint associated with the railing found along the top of the expressway walls in this section.

BIN 1050149 - Broad Street Bridge

- White to grey HID light backer board material.
- Bearing pad material.
- **White to grey pre-molded joint filler/expansion joint found between sections of the retaining walls and where the retaining walls meet the bridge abutments.**
- Black sheet packing materials found behind the joint filler/expansion joint.
- Green paint associated with the bridge and bridge railings found along the top of the expressway walls in this section.

BIN 1035240 - East Avenue Bridge

- **White to grey pre-molded joint filler/expansion joint found between sections of the retaining walls and where the retaining walls meet the bridge abutments.**
- Black sheet packing materials found behind the joint filler/expansion joint.
- **Utility pipe insulation.**
- Bearing pad material.
- Green paint associated with the bridge and bridge railings found along the top of the expressway walls in this section.

All the white to grey expansion joint materials found between the retaining walls section vertical joints and the bridge abutment transitions to the adjacent retaining walls must be considered asbestos containing. The black sheet packing found behind the joint materials in non-asbestos containing.

The following suspect materials identified on the record plans were not able to be sampled in the field because they were not accessible to the asbestos inspectors:

- Bituminous material apparently applied to the backs of all abutments and walls above tops of footings. If these materials are exposed during demolition, samples should be collected for laboratory analysis to determine if asbestos is present in this material.
- **Compressed asbestos sheet packing (located on top of the back walls). This material must be assumed to be positive and be removed following abatement procedures if encountered in the field during bridge demolition. It was not identified in the field.**

Any removal/disturbance of asbestos-containing materials will need to be performed by a New York State licensed asbestos abatement contractor. It is recommended that Blanket Variance 14 be utilized for the removal of the identified asbestos-containing materials.

If any additional suspect material is observed during the construction period, the Construction Inspector/Engineer in Charge should be immediately notified. Representative samples of the suspect materials should be collected and analyzed for asbestos content in accordance with NYSDOT procedures.

Asbestos Special Notes and Specifications will be prepared to address proper mitigation and disposal of the asbestos materials. These Asbestos Special Notes and Specifications will be prepared by personnel with an Asbestos Designer License.

4.4.19 Hazardous Waste and Contaminated Materials

4.4.19.1 Lead Based Paint -

The project corridor was screened to determine the potential presence of lead based paint within the proposed project limits. This screening resulted in the following:

- The railings located at the top of the expressway retaining walls are painted green throughout the corridor. The railings on the bridges (Broad, East and Main) crossing over the expressway are painted green as well. All of these bridges are painted with this similar green paint.
- Silver painted light poles in the vicinity of the Monroe Avenue Bridge.
- The railings on the Monroe Street Bridge are newer galvanized railings. The deck on the Monroe Street Bridge was replaced in 2000, and the beams/girders have a brown appearance.

No other suspect materials were identified within the project corridor. The above referenced locations were tested for the presence of lead by readings obtained by using an Innovex XRF device in the field. Any sample of paint testing 1.0 mg/cm^2 is considered positive and identified as a lead-based paint by regulation. Based on these results all bridge and railing components that have green paint must be considered to contain lead based coatings. The silver paint associated with the light poles in the vicinity of the Monroe Street bridge section should also be considered positive for the presence of lead.

4.4.19.2 Hazardous Waste and Contaminated Materials -

Screening and Site Assessment

A Hazardous Waste/Contaminated Materials Site Screening (a.k.a. NYSDOT Phase I Environmental Site Assessment (ESA)) was conducted in accordance with NYSDOT's The Environmental Manual (TEM) Section 4.4.20 "Contaminated Materials and Hazardous Substances" (Updated November 2011) and the NYSDOT Environmental Procedures Manual, Chapter 5, in order to document the likely presence or absence of hazardous/contaminated environmental conditions. A hazardous/contaminated environmental condition is the presence or likely presence of any hazardous substances or petroleum products (including products currently in compliance with applicable regulations) on a property under conditions that indicate an existing release, a past release, or a material threat of a release of any hazardous substances or petroleum products into structures on the property or into the ground, ground water, or surface water of the property.

The Hazardous Waste/Contaminated Materials Site Screening included a review of NYSDEC/USEPA regulatory data files and a site 'walkover' on June 5, 2013. The Hazardous Waste/Contaminated Materials Site Screening identified thirty-five (35) Hazardous Waste/Contaminated Materials sites or groups of sites within or adjacent to the project corridor based on their historical use, database records or observations in the field.

Sites with historic evidence of mapped underground storage tanks (UST) locations that are within or immediately adjacent to the proposed limits of construction are identified below. These sites are most likely to have a potential impact on the project. Special notes and a figure showing the exact location of each of those sites with tanks that are within or immediately adjacent to the area of construction will be prepared for the PS&E package advising the Contractor and EIC that soil contamination may be expected in these areas:

- Mapped USTs were identified beneath the parking lot at approximately 83 North Union Street/287 University Avenue. This area is currently not scheduled to be developed but is located between the proposed Inner Loop roadway and North Union Streets. Since it appears no construction of note ever occurred in this area, the tanks and surrounding soils may still be present;
- A mapped UST was identified in the grassy area between Pitkin Street and the Inner Loop ramp approximately 100 feet south of the intersection of Pitkin and Richmond Streets;
- A mapped UST was identified at a former automobile manufacturer at the northwest corner of Inner Loop and Chestnut Street adjacent to the sidewalk on the north side. Current location

would be near the southeast corner of the parking ramp located on the city block bound by Pitkin Street/Inner Loop ramp, South Clinton Avenue, Woodbury Boulevard, and Chestnut Street;

- Mapped USTs were identified at a former gas station near the southwest corner of Johnson Place and Chestnut Street with USTs identified beneath what is now the parking lot and roadway; and,
- Mapped USTs were identified at a former gas station with numerous USTs in the area of the triangle intersection of Inner Loop and Chestnut Street. Due to their location it is presumed that all the tanks have been removed but some residual contaminated soil may be encountered during any excavation work completed in this immediate area.

The excavation contractor will be informed of the historical uses at each of these properties of potential environmental concern for purposes of health, safety, and preparedness. During construction, USTs (if present) should be removed and properly closed and soils encountered with signs of contamination should be segregated to await sampling and characterization. Once the soils are characterized they should be disposed of in accordance with all applicable regulations. A soil management plan that contains contingency actions for the removal and mitigation of any encountered contaminated soils should be developed as part of this project.

A copy of the Hazardous Waste / Contaminated Material Screening report is located in Appendix J.

4.4.19.3 Contaminated Materials (Other) -

The Monroe Avenue Bridge has extensive bird guano deposits and dead bird carcasses especially on the southern bridge pier abutment that will have to be handled safely during construction to prevent worker exposure to these materials and the chance of contracting histoplasmosis, cryptococcal meningitis and other diseases.

4.5 Construction Effects

Each of the potential construction impacts and mitigation measures have been identified and discussed in the respective sections and subsections above. However, the single most notable construction related impacts involve disruption to local travel patterns and construction related noise impacts. Disruption to local travel patterns will occur as a result of temporary detours and congestion due to construction activities. Construction related Impacts and Mitigation Measures are discussed below.

4.5.1 Construction Impacts

Construction noise will occur, however, construction noise differs from traffic noise in the following ways:

- Construction noise only lasts for the duration of the construction contract;
- Construction activities are usually limited to the daylight hours when most human activity takes place;
- Construction activities are generally short term; and
- Construction noise is intermittent and depends on the type of operation.

The project will include the construction activities of excavation, sub-base preparation, roadway millings, placement of fill via dump trucks, and other miscellaneous work.

4.5.2 Mitigation Measures

Certain mitigation measures can be incorporated into the contract documents to reduce construction noise in the project area. The following mitigation strategies are likely to be used for this project:

- Use of exhaust systems in good working order, engine enclosures and intake silencers;
- Regular equipment maintenance;
- Use of new equipment subject to new product noise emission standards;

- Placement of stationary equipment as far away from sensitive receptors as possible;
- Strategic choice of staging sites and C&D disposal sites; and
- Limitations on work hours.

4.6 Indirect and Secondary Effects

The proposed project has the potential to indirectly affect social conditions by impacting land use, community character, and the local economy by spurring growth. One of the project benefits previously discussed is that it will create development parcels that can accommodate up to 795,000 square feet of mixed-use real estate development. Based on real estate market estimates included in the Real Estate Market Analysis Report, new development could support a total land value of all parcels between \$8.0 million and \$11.5 million.

4.7 Cumulative Effects

Other than the secondary impacts associated with the future development of the new parcels, which will be subject to review and approval by the City of Rochester, no cumulative effects are anticipated with this project. The project is essentially a transformation of an existing roadway corridor.

4.8 Irreversible and Irretrievable Commitments of Resources

Implementation of the proposed project involves a commitment of a range of natural, physical, human, and fiscal resources. Land used in the construction of the proposed facility is considered an irreversible commitment during the time period that the land is used for a highway facility. However, if a greater need arises for the use of the land, or if the highway facility is no longer needed, the land can be converted to another use. At present, there is no reason to believe such a conversion will ever be necessary or desirable.

Considerable amount of fossil fuels, labor, and highway construction materials such as cement, aggregate, and bituminous material are expended. Additionally large amounts of labor and natural resources are used in the fabrication and preparation of construction materials. These materials are generally not retrievable. However, they are not in short supply and their use will not have an adverse effect upon continue availability of these resources. Any construction will also require a substantial one-time expenditure of both State and Federal funds which are not retrievable.

The commitment of these resources is based on the concept that residents in the immediate area, State, and region will benefit by the improved quality life. These benefits will consist of improved accessibility and safety, savings in time, and greater availability of quality services which are anticipated to outweigh the commitment of resources.”

4.9 Adverse Environmental Impacts that cannot be Avoided or Adequately Mitigated

The environmental impacts identified to date for this project that cannot be avoided have been mitigated to the greatest extent practicable. While certain construction related impacts will occur despite mitigation, the resulting impacts will relatively short-term and temporary in nature, much like other City roadway reconstruction projects that occur throughout the region.

CHAPTER 5 – PUBLIC HEARING COMMENTS AND RESPONSES

5.1 Oral Comments Received at the February 4, 2014 Public Hearing

The following includes responses to address public comments on the Draft Design Report for the Inner Loop East Transformation Project received at the Public Hearing held on February 4th, 2014. These comments were presented orally and are summarized below; the stenographer transcript contains verbatim comments (see Attachments).

5.1.1 Michael Knight, Buena Place

Comment: Mr. Knight stated that he has lived on Buena Place for the past 40 years. He commented that the problem with parking should have been taken care of years ago and some people here don't understand the nature of the problem (animosity, inconvenience, isolation). He observed that lots of people were in agreement when the parking issue was brought up earlier in the evening and proposed that a committee be established to address the issue. Mr. Knight thanked everyone for their time.

Response: *The proposed design has maximized parking within the corridor by providing on-street parking along both sides of Union Street where feasible. The project will create more parking spaces than currently exist along South Union Street.*

5.1.2 Steven Venturino, South Union Street

Comment: Mr. Venturino stated that there were two problems he wished to comment on – street cleaning and snow removal, both of which impacts parking. He stated that plans for this should consider the system on Park Avenue (1 hour parking restriction for cleaning/snow removal). He also commented on handicap parking and asked whether this plan considers an improvement in handicap parking. He commented that the COR has done a great job at branding different areas, but wondered whether thought had yet been given to branding this area (uniqueness). He also commented that he expects that all of the old signage is being considered in the design plan. His final comment questioned whether Union Street will still be an emergency snow route and that snow emergencies should be considered in the plan.

Response: *Please see response to comment 5.1.1 above. The City can incorporate handicap parking, if there is a need identified, but up until this point the City is not aware of a particular need. Union Street will remain an emergency snow route. No decision in that regard has been made. Lastly, this project will evaluate all of the existing signing and make the necessary changes.*

5.1.3 Dawn Williams-Fuller, Ambassador Union Street, LLC

Comment: Ms. Williams-Fuller re-iterated the need for residential, non-metered parking, especially south of Broad Street. Metered residential parking is not friendly and not livable although it is understood for the upper area (more commercial). She emphasized the comments by the previous speaker pertaining to cleaning and snow removal and its impact on parking (cannot switch over, blocks traffic). She also commented that the branding idea presented by the previous speaker was a great idea.

Response: *Comment noted. Please see the response to comment 5.1.1 above. The City of Rochester will incorporate this input into their assessment as they develop a parking strategy for Union Street. No decision has been made at this point of the project.*

5.1.4 Joey Lanzone, staff writer for Roc Insomniac

Comment: Mr. Lanzone stated that he believes we should fix what we have before we move onto other things; he gave the example of the old Cadillac Hotel on Atlas Street as a location that should be cleaned up prior to fixing this [Inner Loop East project area].

Response: *Comment noted. The comment reflects an opinion; therefore, no response is required.*

5.1.5 Jack Darcy, property owner within project area

Comment: Mr. Darcy commented that this is a momentous time in the City's history to set the tone for the future. He states that beautification (including superior landscaping) is of critical importance and that it would be a wise investment and a cooperative effort can make the vision a reality. He suggested "gardenscape" as a branding; he commented that the beautification can transform a struggling area to a prosperous, livable area. Mr. Darcy stated that the current parking struggles needs to be part of the plan. Mr. Darcy suggested that staging of construction should be considered in the plan – when the project area is torn up, the surrounding area will have a negative perception which can hurt businesses and the community. Mr. Darcy next commented on the new buildable parcels, stating that the application process should require development applicants to say how the development will help the area, how the development complies with beautification and vision, and to demonstrate that the type of development is needed – shouldn't be sold to the right bidder alone. Mr. Darcy stated that it was his understanding that funding from the TIGER grant will provide some landscaping funds but funding is needed to perpetually maintain this as well as maintain the developable parcels until the bidding/buying/developing process begins. Mr. Darcy, as a major stakeholder, stated that a committee is needed to pursue the beautification and vision aspect of this project along with future development compliance with both; he stated that he is willing to serve on such a committee.

Response: *Landscaping and beautification efforts are very important to the overall success of the project. The future development of the parcels will accomplish and promote the various community characteristics identified by the City of Rochester and neighborhood groups and coalitions. Each development parcel will be subject to review by the City of Rochester as developers come forward and site plans are prepared. Each development parcel will be reviewed for consistency with the Center City Master Plan and other applicable City codes, which includes provisions for landscaping and overall aesthetics.*

The City would support a landscaping assessment district if the adjacent owner's wanted to consider this.

Please see response to comment 5.1.1 above regarding parking concerns. During the final design phase, the City will be developing a staging plan for the entire project. The intent of the staging plan will be to minimize impacts to adjacent residents and landowners, while allow the contractor to efficiently construct the project.

5.1.6 Chris McCamic, Buena Place

Comment: Mr. McCamic stated that this project has a lot of potential but there was something a bit dishonest about the schematics (lots of trees/green spaces but truly will be developable parcels). He stated that public space (green space, permaculture, urban gardens) outweighs economic development benefits and that the current parking problems would get worse. He also agreed with the committee suggestion by the previous speaker and that he would too serve on such a committee.

Response: *Please see the response to comment 5.1.1 above regarding parking. The comment reflects the opinion of the commenter; therefore, no response is required. The schematics are not intended to mislead any reviewer. The schematics attempt to depict the total amount of anticipated street trees.*

5.1.7 Edward Steinberg, Lafayette Park

Comment: Mr. Steinberg commented that the South Union development parcels would be zoned CCD which implies they will have to meet design standards which should be emphasized in this decision making process concerning future development. He stated that the area itself is historical – high-caliber historic designations on Lafayette, Canfield, and Buena. He mentioned the Georgian townhouses promised view of downtown (would be affected by this project). Mr. Steinberg also commented on the Howell Street thoroughfare planned alignment – he stated that a lot of traffic flows onto the dead end street because people think it's a through-street and the project's design alignment would increase the probability of this. He mentions that geometric curb blinds and street narrowing which are designed to help present another set of problems. Mr. Steinberg states that it should enter north and not be aligned.

Response: *The South Union Street development parcels will be zoned CCD. Therefore, the development of these parcels will have to meet the intent and guidelines identified in the CCD requirements. Each development parcel will be subject to review by the City of Rochester as developers come forward and site plans are prepared. Each development parcel will be reviewed for consistency with the Center City Master Plan and other applicable City codes, which includes provisions for landscaping and overall aesthetics.*

The proposed intersection configuration for Howell Street, Union Street and Lafayette Park has been revised to address the concern that Lafayette appears to be a thru-street versus the fact that it is a dead-end street. The revised configuration eliminates the curb radii from Union Street to Lafayette Park, proposes a continuous curb line and sidewalk with a typical driveway apron entrance for Lafayette Park, and includes a new dead end warning sign.

5.2 Written Comments Received at the February 4, 2014 Public Hearing

No written comments were received at the Public Information Meeting/Public Hearing held on February 4th, 2014

5.3 Written Comments Received via E-Mail Following the Public Hearing

The following includes responses to address written public comments on the Draft Preliminary Design Report for the Inner Loop East Transformation Project, received via e-mail following the Public Hearing held on February 4th, 2014. The public comment collection period closed February 14th, 2014. These comments (or pertinent excerpts of these comments) are included below verbatim and hard copies are presented in the Attachments.

5.3.1 Anthony Mittiga

Comment: "I attended the presentation on February 4 at the Central Library, and want to commend you, and the other officials, for answering the many questions. Frankly, I did not have any questions myself, since I've been following this plan in the "D&C". I'm in favor of the plan as given, and confident that details on signage, pedestrian safety, parking, and so on, will be worked out as time goes on..."

Response: *The comment reflects the opinion of the commenter; therefore, no response is required.*

5.3.2 Colleen McCarthy, Lock 66 Neighborhood Association

Comment: "I did not locate a place for public comment @ cityofrochester.gov; therefore, I am sending a brief email regarding concerns about the Inner Loop East Transformation Project.

The proposed design of Howell/Inner Loop/Pitkin and Monroe/Chestnut is not pedestrian friendly. The proposed design of the right turn lane on Chestnut Street is dangerous for pedestrians. The northbound lane of Monroe Avenue to westbound Pitkin towards 490 is unsafe for pedestrians due to high speed left turns from Monroe Avenue.

If the design is not pedestrian-friendly and safe, Monroe Avenue neighborhoods will remain separated from the core of downtown. The goal of reconnecting neighborhoods with downtown is not accomplished by the current design..."

Response: *Integrating safe pedestrian access through the Monroe/Chestnut/Howell intersection has been given significant attention during the preliminary design process. The goal has been to balance the needs of all the users, including pedestrians, bicycles, and vehicles.*

The Chestnut Street southbound right turn slip lane is essential to minimize the size of the Monroe/Chestnut/Howell Street signalized intersection. This slip ramp is anticipated to carry over 1,285 vehicles per hour getting on the I-490 expressway system. If this slip ramp was eliminated and all these vehicles were forced to turn right at the traffic signal, multiple (triple right turns) lanes would be necessary. Multiple right turn lanes at the Monroe/Chestnut/Howell intersection would have significant impacts on the intersection, bicycle and pedestrian access. The right turn lane on Chestnut Street to access the expressway is currently two (2) lanes and will be one (1) lane in the future. Additional safety improvements include high visibility pavement marking and traffic signs.

A pedestrian on Monroe Avenue heading downtown using the proposed intersection design will cross fewer lanes in comparison to the existing layout. Since the Public Information meeting, the east leg of the intersection has also been modified to enhance the pedestrian experience by eliminating the westbound left turn lane and replacing it with an island for pedestrian refuge.

5.3.3 Allan Richards, Wadsworth Square Neighborhood Association

Comment: “On behalf of the Wadsworth Square Neighborhood Association, we are pleased to take the opportunity to comment on the design of the Inner Loop East Transformation Project and its impact on the families and businesses of the Wadsworth Square Neighborhood. We have supported this project through two federal application processes. We agree that: “The transformation of this expressway into an at-grade complete street supporting bicycle and pedestrian traffic will create a more livable and walkable community thus resulting in substantial social, health, fiscal and economic benefits.” While there is much to remark upon regarding the project, we would like to limit our comments and draw your attention to the areas of the current Monroe/Chestnut intersection and the Monroe/Union Street intersection.

The intersection of Monroe/Chestnut and Howell/Inner Loop/Pitkin has been an area of great concern. The current configuration of this interchange is unpleasant, intimidating and dangerous for pedestrians. It discourages people from walking downtown. This concern was raised at a meeting held with the Wadsworth Square Neighbors and representatives from the City and Stantec. Additionally, at the November 6, 2013 meeting at Manhattan Square Park these concerns were once again raised by Wadsworth Square neighbors as well as by other participants. The Wadsworth Square neighbors were disappointed to see a design presented at the February 4, 2014 meeting that still did not address these concerns. While the bridge over the Inner Loop has been removed, there are still too many lanes to cross, the traffic island and right turn lane on Chestnut Street remain essentially unchanged and nothing has been done to discourage high speed left turns from the northbound lane of Monroe Avenue to the westbound lane of Pitkin Street leading to I-490, which create dangerous conditions for pedestrians.

We believe that the current design does not fulfill two of the four project objectives:

- Supporting Healthy Lifestyles and Improving Livability: By providing a boulevard with wide sidewalks and dedicated bicycle facilities while leveraging mixed-use infill development, the project encourages bicycle and pedestrian activity, helping to create a more livable and sustainable community.
 - While this statement may be applicable to S. Union Street, The bicycle and pedestrian experience for users of Monroe Avenue/Chestnut will improve little, if at all.

Response: See response to comment 5.3.2 above.

- Reconnecting Neighborhoods with Downtown: It will remove a significant barrier to redevelopment in the East End, one of Rochester’s most important downtown districts, and reconnect thriving east side neighborhoods with the downtown area.
 - By failing to significantly reduce the width of the Inner Loop between I-490 and Monroe Avenue/Chestnut Street and by raising this overly wide roadway to grade, the barrier between downtown and Wadsworth Square has not been reduced at all. This comes at the cost of a reduction of the amount of developable land that can be made available, which in turn will reduce the return on investment for the project.

We have been told, by the City, that the current design is the only one that will be approved by the New York State Department of Transportation. If that is the case, we ask that the state DOT come and meet with the neighborhood to explain its choice, as our conversations with the State indicate there may be room for further discussion.

Response: The portion of the project from I-490 to Monroe/Chestnut is considered part of the I-490 expressway system (accommodates on and off ramps) and therefore needs to meet current design standards as well as accommodate projected traffic volumes. The proposed alternative is recommending a narrower pavement width from existing conditions within this segment of the project.

The second area of concern is the intersection of Monroe/Union. Currently, Union Street is a continuation of Broadway, which serves as an exit ramp from I-490 to the Inner-loop. It is our understanding that the city would like to reconfigure these streets to make them two way streets. With the Inner Loop East Transformation Project calling for the discontinued use of Union as a one-way street between Main Street and Monroe Avenue, it is only logical to extend that benefit to the section of Broadway/Union from the I-490 exit to Monroe Avenue. This would help in fulfilling another touted benefit of this project: Increasing Traffic Safety. Additionally, the reconfiguration of these traffic patterns will preserve the residential nature of Broadway and surrounding neighborhood streets and reduce the high speed traffic that we currently experience. We would encourage the city to approach the county and the state to accomplish this task while reconstructing Union Street..."

Response: The City of Rochester has long term plans to re-evaluate and possibly convert the segment of Broadway from the I-490 exit ramp to the Monroe Avenue to two-way operations. This is a separate project that is outside of the project limits and therefore is not included in the current funding.

5.4 Written Comments Received via Mail Following the Public Hearing

The following includes responses to address written public comments on the Draft Preliminary Design Report for the Inner Loop East Transformation Project, received via mail following the Public Hearing held on February 4th, 2014. The public comment collection period closed February 14th, 2014. These comments are included below verbatim and hard copies are presented in the Attachments.

5.4.1 John Glassman

Comment: "The Inner Loop has been an integral and efficient means for people who live and work and travel in and around Rochester downtown for many years. In fact, Rochester's ease of travel has long been one of its' best features when promoting the area to prospective new comers. The Inner Loop provides optimal routing for both car and truck traffic to all feeder routes in and out of the downtown central area. Rochester Downtown itself can be fully navigated in a nominal time of just a few minutes, often faster than the time one will sit at single traffic light on a standard city street. The Inner Loop Transformation Draft Design Report – Volume 1 talks about model studies to determine impact to other routes and determined that the Level of service of other roads would remain at Good level and themselves would not be negatively impacted. But this fails to recognize the true travel time impact to the individuals who do use the current route now and in the future and to what degree these changes will have. While a rate of 200 car per hour that use that section of the loop may seem low on a comparison basis to other routes, it still represents thousands of people who travel in and around the city daily and need to get where they are going in a predictable time frame. How will this effect response time for police, fire and ambulance? Just because Union St. does not have any stations in that section does not mean forcing these services to take other routes will not have an Impact on their response times. The report completely dismisses the need to do time of travel and delay impact when the current highway route and bypass is no longer a viable option for drivers. I find this unacceptable and ask that this project not be allowed to precede without performing and evaluating Travel Time Estimates and comparing them with current possible routes and then with the alternative routes with the proposed routing changes."

[Cites 3.3.1.5 Speeds and Delays (paragraphs 1 and 2) from January 2013 Draft Design Report PIN 4940.T7]

Response: *One of the first questions addressed at the initiation of the Inner Loop East project was to identify the overall impact of removal of the Inner Loop expressway on the regional transportation system. This question was addressed by using state of the art regional travel demand model developed and calibrated by the Genesee Transportation Council Metropolitan Planning Organization for the greater Rochester regional area. GTC modeled the elimination of the Inner Loop East and provided the relative change in travel patterns in the area and region. The model results showed little to no effect on the surrounding roadway network. This addressed the pivotal question for the Federal Highway Administration that has allowed this project to receive federal funding and progress to construction.*

As part of the project's development process, the design team has coordinated with the City of Rochester's Police Department and Fire Department.

The travel time and delay section in the design report was not dismissed. This section notes that the project will provide acceptable levels of operations and therefore travel time and delay calculations are not required to be calculated.

5.4.2 James Cerniglia

Comment: "I whole heartedly support the concepts Jack Darcy put forward at the information meeting on 2/4 in Gleason Aud. The developable land made available after removal of Inner Loop East should be competently and professionally landscaped to reflect "Gardenscape" concept and to represent Rochester's illustrious history as the "Flower City". This all-green concept of an urban streetscape park concept would make it a unique area in this city. Park benches, outdoor sculptures and yes, even fountains need to be part of urban living in the 21st century. If any of these land parcels were to go for development, a precedent/expectation of what they're supposed to be would already be evident to any potential developer(s). Rochester needs to follow the example of New York City's completed plans for the former West Side Highway. Once completed, these redesigned areas become a magnet for events both cultural and inter-social.

Urban renewal of 50+ years ago carved the heart out of a once-vibrant city for the benefit of urban/suburban traffic flow. It's a unique opportunity to heal that wound and reunite city neighborhoods! Taxpayers are watching and counting on this!"

Response: *Comment noted. This comment reflects an opinion; therefore, no response required.*

5.4.3 Roger Brown, Rochester Regional Community Design Center

Comment: "I am writing on behalf of the Rochester Regional Community Design Center (RRCDC) regarding the proposed Inner Loop Project for the Center City's southeast section of that roadway that will be removed as part of a project partially funded by a Federal TIGER Grant secured by the City. The RRCDC, as you are aware, has worked on and submitted our suggestions for this project. We have presented ideas in public sessions and in other meetings with the City and its consultants. I am resubmitting these materials with this correspondence, along with a letter from consultant Jeff Speck, whose comments were offered separately by him in direct correspondence with the City. I am attaching these for your convenience here.

Without going into great detail, as the Rochester Regional Community Design Center (RRCDC) is still of the belief that in general the Plan of 1/30/14 is much too heavy on design elements that diminish the pedestrian experience. Though much improvement to the Plan has been accomplished there are still too many vehicular travel and left turn lanes; the vehicular lanes are too wide; and not enough attention is paid to incorporating wider tree lawns (growing good tall healthy street trees require space – good tall healthy trees add tremendous value, environmental and economic, to neighborhoods).

Response: *The plan has been refined substantially to reduce the number of travel lanes and provide additional tree lawn widths. Recently, the center turn lane was eliminated on Howell Street from Monroe Avenue to Union Street and on the north end of Union Street between East Avenue and University. In addition, through input from RRCDC a secondary row of trees was incorporated*

in the design between the sidewalk and the cycle track and between the cycle track and parking lane.

We understand the desire for a cycle path but the design as presented has too much going on to the detriment of the pedestrian. The cycle path appears to make extremely awkward intersections for the pedestrians. Certainly the double row of trees on Union Street is a positive feature but the resulting layout needs wider tree lawns (on both the east and west sides). Reducing the land widths would help this situation and, for sure, removing the center lane would be the preferred solution.

Response: *One of the project goals is to provide a multi-modal system for all users. The cycle track provides dedicated bicycle lanes along the corridor. Similar to junctions with vehicular traffic, points where the cycle track and sidewalk system meet, special attention is warranted. The design and layout of the cycle track with the pedestrian system and street are being designed per National Association of City Transportation Officials (NACTO) Urban Bikeway Design Guide and Manual for Uniform Traffic Control Devices (MUTCD), which are national guides and standards for this type of bicycle treatment.*

[Attached: Inner Loop Design Alternatives, Meeting, Date: 11.15.13]

5.4.4 RRDCDC Inner Loop Design Alternatives

Design Alternatives to Consider

- Create Union Street as a “place” similar to Park Avenue in Character, pedestrian focused.
- Incorporate generous tree lawns (8’) with street trees at 30’ on center.

Response: *The City standard tree lawn area is five (5) feet, as proposed in the corridor. Providing wider tree lawns would increase the right-of-way, impact existing underground utilities, and minimize economic development parcels. Striking a balance of all the desired street amenities is the project goal. Thirty foot tree spacing is being considered, where possible, along with structural soil to improve the root zone.*

- Vehicle travel lanes should be no greater than 11’ and preferably 10’ - two travel lanes is preferred over three.

Response: *Eleven (11) foot and 12’ travel lanes are provided along the corridor to accommodate vehicles and bicycles. The project is proposing using the minimal width that is allowed per the design standards.*

- Always separate the pedestrian from both bikes and vehicles by the 8’ tree lawn buffer.

Response: *Western side of Union Street - The current plan provides a 5’-6” separation between the pedestrians and the bikes. The distance between the pedestrians and the vehicles is 20’-6”.*

- Consider removing the cycle track in favor of in-street striped lanes each side of the roadway. (This is becoming an understood system). If the cycle track is required it should be placed next to the roadway with a 2’-8’ separator.

Response: *The City has decided a two-way cycle track is desired along this corridor. Cycle tracks provide dedicated and protected space for bicyclists by improving perceived comfort and safety. Cycle tracks eliminate risk and fear of collisions with over-taking vehicles. They reduce risks of “dooring” (from parked cars) compared to a bike lane, and eliminate the risk of a “doored” bicyclist being run over by motor vehicles (NACTO Urban Bikeway Design Guide). Separation between the parking/travel lanes have been incorporated according to national recommendations.*

- Incorporate pedestrian scale lighting throughout.

Response: *Decorative street lighting will be provided per city standards (14' post tops).*

- Provide generous crosswalks at all intersections and consider mid-block crosswalks where necessary.

Response: *Crosswalks are provided at each signalized intersection and at un-signalized intersections.*

- Design alleys as one-way tree lined narrow streets with sidewalks and street trees. (On-street parking where appropriate).

Response: *The only alley way that is being reconstructed as part of this project is Dryer Alley. In this particular case, there is limited ROW, therefore making it prohibitive to provide on-street parking with street trees.*

- Create special zoning code for this area and street – special overlay district.

Response: *Commented noted. At this time, this is not part of the overall project's scope of work.*

- Consider breaking down parcels into smaller sizes.

Response: *Commented noted. At this time, this is not part of the overall project's scope of work.*

- Building types
 - 3-4 story town houses – park under or double loaded alley or granny flats.
 - 4 story apartments/condos with double loaded corridor (the Mills) – or park under.
 - 4 story apartments/condos with single loaded corridor and courtyard – park under.
 - 5-6-7 story tower – park under.
 - 3-4 story live/work units
 - Stacked townhouses (2- 2story)

Response: *Commented noted. At this time, this is not part of the overall project's scope of work.*

- Let the developer design the alleys per the needs of their proposal – dedicate to the city?

Response: *Commented noted. At this time, this is not part of the overall project's scope of work.*

- Underground parking in the old depressed roadway?

Response: *Commented noted. At this time, this is not part of the overall project's scope of work.*

- Opportunity for a central green?

Response: *Commented noted. At this time, this is not part of the overall project's scope of work.*

Original Cycle Track Scheme - Negative Issues:

- 20' paving from the curb (West side).
- No buffer separation between the sidewalk and cycle track (poor pedestrian experience).
- Three lanes of traffic (old scheme had two).
- Sometimes thin tree lawns on the east side (5').

Response: *The proposed plan has been notably refined since these November 2013 comments and now incorporates 30' tree spacing, a tree lawn between pedestrians and bikes, lane modifications, etc.*

Cycle Track Scheme # 1 - Features:

- The pedestrian is separated from the cycle path by a tree lawn (trees at 30' on center).
- The cycle track is separated from the on-street parking by a tree lawn.
- Two traffic lanes. (11')

Response: *The proposed plan has been notably refined since these November 2013 comments and now incorporates 30' tree spacing, a tree lawn between pedestrians and bikes, lane modifications, etc.*

Cycle Track Scheme #2 - Features:

- The pedestrian is separated from the cycle path by a tree lawn (trees at 30' on center).
- The cycle track is separated from the on-street parking by a 3' concrete separator.
- Two traffic lanes.

Response: *The proposed plan has been notably refined since these November 2013 comments and now incorporates 30' tree spacing, a tree lawn between pedestrians and bikes, lane modifications, etc.*

On – Street Cycle Lanes - Features:

- The pedestrian is separated from the vehicles and cyclist by a tree lawn.
- There is a narrow Right of Way (74")
- These are standard cycle lanes are common to typical Rochester layout.
- Increased area of developable land.

Response: *The City has decided a two-way cycle track is desired along this corridor. Cycle tracks provide dedicated and protected space for bicyclists by improving perceived comfort and safety. Cycle tracks eliminate risk and fear of collisions with over-taking vehicles. They reduce risks of “dooring” (from parked cars) compared to a bike lane, and eliminate the risk of a “doored” bicyclist being run over by motor vehicles (NACTO Urban Bikeway Design Guide). Separation between the parking/travel lanes have been incorporated according to national recommendations.*

[Attached: Inner Loop Design Alternatives, Meeting, Date: 11.15.13]

5.4.5 Jeff Speck, Speck & Associates, LLC

Comment: “I was recently asked by Tim Raymond and Linda Magi to review the current plans for the Connector. I have taken the time to do this *pro bono*, because I see great opportunity for improvement.

Whenever a highway is replaced by a street, and that street is designed by highway engineers, there is a justifiable fear that the street will turn out as a narrower highway. Given that streets create property value and social capital, while highways sunder property value and social capital, it is essential that every effort be made to avoid a narrow-highway outcome. Helping you to achieve that end is the purpose of this memo.

The critique that follows is based on the January 30 design available on the City website. Looking at the plan from southwest to north, here are my comments:

- There should be no slip lane for the right turn at the Chestnut/Howell intersection. Slip lanes are a high-speed detail that has no-place on urban streets.

Response: *Integrating safe pedestrian access through the Monroe/Chestnut/Howell intersection has been given significant attention during the preliminary design process. The goal has been to balance the needs of all the users, including pedestrians, bicycles, and vehicles.*

The Chestnut Street southbound right turn slip lane is essential to minimize the size of the Monroe/Chestnut/Howell Street signalized intersection. This slip ramp is anticipated to carry over 1,285 vehicles per hour getting on the I-490 expressway system. If this slip ramp was eliminated and all these vehicles were forced to turn right at the traffic signal, multiple (triple right turns) lanes would be necessary. Multiple right turn lanes at the Monroe/Chestnut/Howell intersection would have significant impacts on the intersection, bicycle and pedestrian access. The right turn lane on Chestnut Street to access the expressway is currently two (2) lanes and will be one (1) lane in the future. Additional safety improvements include high visibility pavement marking and traffic signs.

- As it approaches Chestnut from the east, Howell St. gains an unjustified extra lane.

Response: *The approach to Chestnut from the east requires two travel lanes on the intersection approach. The overall geometry at the intersection is a function of intersection volumes and capacity needs. The traffic study assessment has justified the geometric treatments required at this intersection and all intersections in the corridor. Since the Public Information meeting, the westbound left turn lane has been eliminated and an island is currently being proposed.*

- East of Monroe there is a super-long center lane that is wasted pavement and encourages speeding. Only a short left-hand turn lane is warranted into the parking lot to the west. This lane does not correspond with any additional traffic load, and only encourages speeding.

Response: *The center turn lane in this section has been eliminated.*

- This first segment of the street seems to lack parallel parking on both sides. Parallel parking is an essential barrier of steel that protects pedestrians from moving vehicles and gives life to adjacent development. A sidewalk without parallel parking is not an adequate pedestrian facility. THIS OBSERVATION SHOULD BE APPLIED TO THE ENTIRETY OF THE DESIGN.

Response: *The center turn lane in this section has been eliminated and on-street parking has been incorporated.*

- Howell has a super-long left-hand turn lane west of Union Street, into a tiny one block street that nobody will use. This turn lane should be eliminated, as it only encourages speeding.

Response: *The referenced left turn lane has been eliminated.*

- North of Monroe Avenue, South Union street lacks a long stretch of parallel parking to the west.

Response: *This section of S. Union Street is very narrow. The street width available was optimized to provide two-way traffic operations, bicycle lanes on both sides, sidewalks, on-street parking the entire length on the east side and some new parking on the west side. The limited right of way (ROW) width will not allow for full length of parking without ROW impacts.*

- How wide are the travel lanes? The ITE urban standard is now 10 - 11 feet. 11 feet makes sense for bus corridors that are not up against bike lanes, but otherwise 10 feet should be the standard here throughout. Each extra foot adds design speed and danger.

Response: The proposed project incorporates 11' and 12' travel lane widths, which meet current design standards for this type of facility.

- The same goes for parking lanes. The ITE standard is 8 feet. The video seems to show wider parking lanes, but any wider than 8 feet contributes to speeding.

Response: The on-street parking lanes are 8 feet in width.

- North of Lafayette, the entire block contains a center lane that serves no purpose except to speed cars up. This continuous center turn lane solution is not an urban solution. If space is needed for deliveries, an occasional parking space should be so designated at the curb.

Response: The center turn lane in this section serves a dual purpose. This lane allows for turning vehicles to maneuver in and out of the various side streets/alleys and private driveways. Another purpose is to not preclude the potential for future east/west street connections. The width can then be restriped for future purposes without sacrificing on-street parking and pedestrian facilities to do so.

- North of Canfield, a center turn lane eases motion into a tiny street that is unlikely to get much use. This lane seems unnecessary, and will cause speeding.

Response: The turn lane at Savannah Street is in anticipation of the Woodbury Blvd extension that is not part of this project, but will ultimately provide another cross street further improving neighborhood connectivity and accessibility.

- From this block north to Broad, another useless center lane appears. What is the purpose of this lane? THIS CRITICISM NEEDS TO BE APPLIED THROUGHOUT: Wherever center turn lanes are included that are longer than necessary or simply not needed, they should be eliminated and the carpath (curb-to-curb) narrowed correspondingly. Whoever designed this street seems to have no knowledge of the fact that extra pavement is an inducement to speeding. Since being hit at 35 MPH is ten times as fatal as being hit at 25, the designers are likely to be responsible for many deaths.

Response: The left turn lane at Broad Street and center turn lane have been justified and designed by the traffic study performed per national standards. A left turn lane at Broad Street currently exists at this location today and becomes even more critical when Union Street is converted to two-way traffic operations. The safety assessment performed for the project did not indicate any fatalities within the corridor.

- From Broad Street north, an additional northbound lane has been added. I can find no traffic counts on the NYS map that would suggest the need for this lane. It is common knowledge that a 2-lane street with center turn lanes at intersections can handle 20,000 cars per day. Only if this street is currently handling that much traffic should this additional lane be considered. Otherwise, the entirety of the design should be limited to 3 lanes maximum.

Response: The traffic study included in the design report performed for the project justifies the geometric and operational requirements at each of the intersections in the corridor. Unlike highways that in theory can process 10,000 vehicles per day per lane at free flow speeds, intersection capacity is much more complex as it takes into consideration volume, traffic signal timing and phasing, lane widths, peak hour factors, heavy vehicles, on-street parking, pedestrian and bicycle traffic conflicts to name a few. Every intersection is different and there is no common knowledge of how much traffic an intersection in an urban setting can process without proper analysis.

- Between Broad Street and East Avenue, the wedge-shaped no-drive section in the center of the street is pure highway design. Such useless wedges do not belong in urban streets. The carpath should simply be narrowed by the wedge's width.

Response: *The proposed striping arrangement is necessary to accommodate the introduction of a left turn lane at East Avenue.*

- The left-hand turn lane into East Avenue seems considerably longer than its standard loading condition would require.

Response: *The length of the left turn lane at the East Avenue intersection is justified according to the traffic study performed for the intersection.*

- Parallel parking should be reinstated along the east curb where it is missing.

Response: *On-street parking is shown where feasible. Do to right-of-way limitations north of East Avenue; a parking lane cannot be accommodated.*

- The useless center lane (useful only in encouraging speeding) should be eliminated and the carpath narrowed.

Response: *The center turn lane has been eliminated and the pavement narrowed in this section.*

- The highway swoop on the eastern downramp is antithetical to a low-speed urban block structure. Instead, it would seem that Richmond Street should run continuously east-west, and the highway ramp should T into it, just as it is now shown T-ing into Union. This change would double the size of the adjacent Future Development Area.

Response: *The option to T-in the Inner Loop ramps at Richmond was evaluated. Geometric constraints, grades and intersection operations were cited as reasons for not making this option feasible.*

- Whether or not the above change is accepted, the access point to the highway from this location on North Union would warrant a dedicated left-hand turn lane rather than the dangerous two-northbound-lane solution currently shown, in which the fast lane is also the turning lane.

Response: *A thru-left turn lane was provided to minimize the overall pavement width.*

- From Parker Alley to Hags Alley can be found another useless center lane that does nothing but encourage speeding.

Response: *The center turn lane has been eliminated and the pavement narrowed in this section.*

5.4.6 Dawn Williams-Fuller, Ambassador Union Street, LLC

Comment: "This letter follows up on the input and comments provided by Ambassador Union Street, LLC at the February 4, 2014 Public Hearing for the Inner Loop East Transformation Project. While we strongly support this project and have seen significant improvements in the plans thus far, we have grave concerns about the plans for metered and highly-restricted parking in our very-residential South Union Street neighborhood.

Ambassador Union Street, LLC owns and manages the Ambassador Apartments located at 86 South Union Street. The Ambassador Apartment complex is a recently renovated, 54-unit, multifamily complex that is home to more than 70 residents. As such, we are one of the largest stakeholders currently residing on South Union Street and will be adversely impacted by any poor decisions that are made as part of this transformation project.

With this letter we would like to clearly state our concerns about the parking plans for South Union Street, and, reiterate the need for residential parking that is not metered or highly-restricted for its residents.

South Union Street is very residential between Broad Street and Monroe Avenue, and, residents living in these areas rely heavily on street-parking to facilitate their everyday lives. Many residents in the area

must park on the street as there is nowhere else for them to park due to the high-density multifamily character of our neighborhood, not unlike the high-density multifamily character of the Park Avenue Neighborhood which provides ample, unmetered, on-street parking for its residents.

In the February 4th Public Meeting/ Hearing, the team presenting the plans to the Public repeatedly stated that one of the key goals of this project was to reconnect the neighborhood and make it more “live-able”.

We would like to state that a key part of making an urban neighborhood “live-able” is – having a place to park on the street when you come home from work (day or night shift) – a spot on the street where you can park without worrying about the meter running out of coins and getting a ticket from a parking attendant or getting towed.

This peace of mind goes a long way to making an urban residential neighborhood “live-able,” even more so than, bike paths and wide sidewalks with trees. Having an unmetered spot to park on the street where you live, is fundamental to people living in the South Union Street neighborhood, as it is to most residential neighborhoods, and, the City should not aim to make a profit at the expense of this very basic need of its Citizens.

Figures 1a through 3c show pictures of unmetered resident parking on nearby neighborhood streets. Oxford Street, in the Park Avenue Neighborhood, is an example of a very residential, tree-lined, beautiful street that provides free (un-metered) on-street parking to its residents. Park Avenue is another example of a very residential, tree-lined, beautiful street that provides free (unmetered) parking for its residents. Even East Avenue, in the areas between Alexander and Winton Street which are very residential, provides free on-street parking to its very wealthy residents. So why would we do any less for the less-affluent residents of South Union Street?

While we welcome a more pedestrian-friendly, bike-friendly, tree-lined beautiful street, a design element as critical as un-metered, on-street, parking for neighborhood residents should have equal weight and consideration in the design plans for the new South Union Street.

Please let us know how we can be of help in providing further input to the parking plans for the new South Union Street. We welcome the opportunity to be on a committee or QIT to help further resolve these parking issues for South Union Street.

Thank you for the opportunity to share our support for this project and to provide input to the design process via the February 4th Public Hearing. If you have any questions, please do not hesitate to contact us.”

[Figures 1a-1e, 2a-2d, and 3a-3c]

Response: Comment noted. The proposed design has maximized parking within the corridor by providing on-street parking along both sides of Union Street where feasible. The project will create more parking spaces than currently exist along South Union Street. The City of Rochester will incorporate this input into their assessment as they develop a parking strategy for Union Street. No decision has been made at this point of the project.

APPENDIX A

Maps, Plans, Profiles & Typical Sections

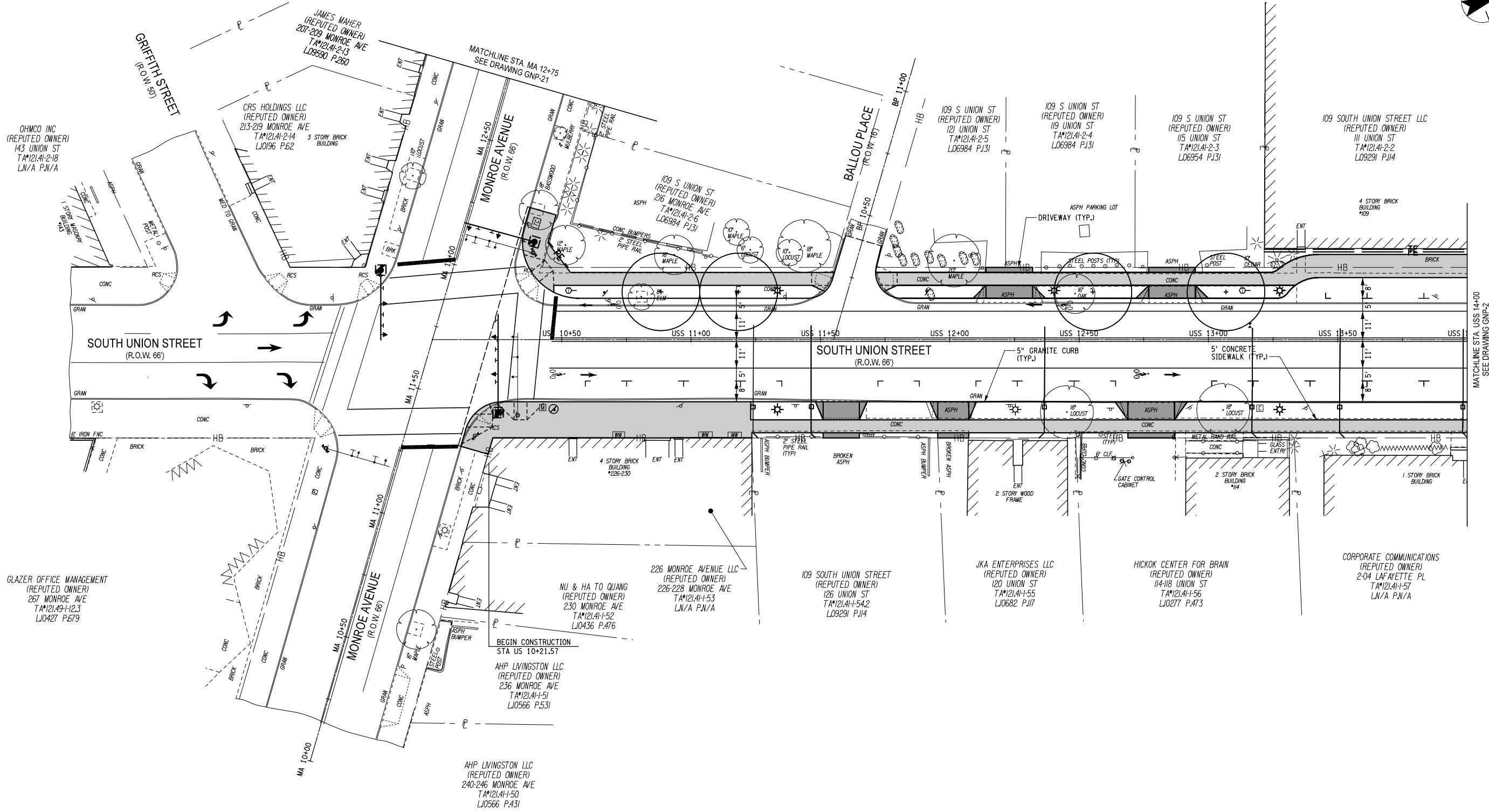

IT IS A VIOLATION OF LAW FOR ANY PERSON, UNLESS THEY ARE ACTING UNDER THE DIRECTION OF A LICENSED PROFESSIONAL ENGINEER, ARCHITECT, LANDSCAPE ARCHITECT, OR LAND SURVEYOR, TO ALTER AN ITEM IN ANY WAY. IF AN ITEM BEARING THE STAMP OF A LICENSED PROFESSIONAL IS ALTERED, THE ALTERING ENGINEER, ARCHITECT, LANDSCAPE ARCHITECT, OR LAND SURVEYOR SHALL STAMP THE DOCUMENT AND INCLUDE THE NOTATION "ALTERED BY" FOLLOWED BY THEIR SIGNATURE, THE DATE OF SUCH ALTERATION, AND A SPECIFIC DESCRIPTION OF THE ALTERATION.

Permit-Seal

Consultants



61 Commercial St, Suite 100
Rochester, NY 14614
www.stantec.com

The Contractor shall verify and be responsible for all dimensions. DO NOT scale the drawing - any errors or omissions shall be reported to Stantec without delay.

The Copyrights to all designs and drawings are the property of Stantec. Reproduction or use for any purpose other than that authorized by Stantec is forbidden.

Client/Project

CITY OF ROCHESTER
INNER LOOP EAST TRANSFORMATION PROJECT
S. CLINTON AVENUE TO EAST MAIN STREET
P.I.N. 4940.T7 D017599

ROCHESTER, NEW YORK

File Name: _____ Dwn. Chkd. Dsgn. 14.03
YY.MM.DD

Title

GENERAL PLAN
SOUTH UNION STREET

Project No.
192500295

Scale
1" = 20'

Drawing No.

Sheet

Revision

GNP-1

XXX of XXX

0

Design File: I:\192500295\Technical\Drawings\Plan Set\PL_design report\GNP-01.dgn
Date/Time: 3/10/2014 8:55:01 AM
Plotted By: KStefmer

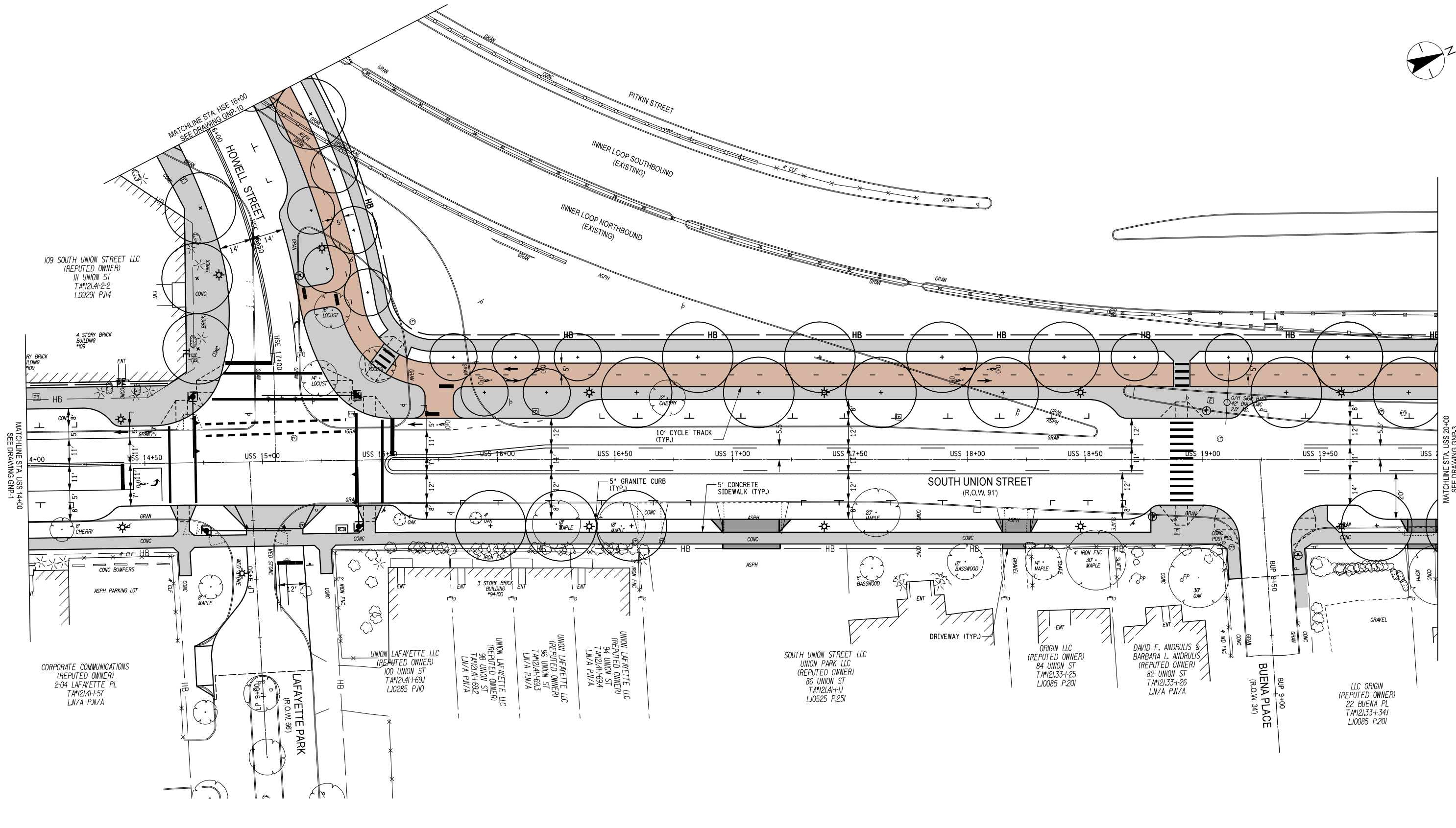

IT IS A VIOLATION OF LAW FOR ANY PERSON, UNLESS THEY ARE ACTING UNDER THE DIRECTION OF A LICENSED PROFESSIONAL ENGINEER, ARCHITECT, LANDSCAPE ARCHITECT, OR LAND SURVEYOR, TO ALTER AN ITEM IN ANY WAY. IF AN ITEM BEARING THE STAMP OF A LICENSED PROFESSIONAL IS ALTERED, THE ALTERING ENGINEER, ARCHITECT, LANDSCAPE ARCHITECT, OR LAND SURVEYOR SHALL STAMP THE DOCUMENT AND INCLUDE THE NOTATION "ALTERED BY" FOLLOWED BY THEIR SIGNATURE, THE DATE OF SUCH ALTERATION, AND A SPECIFIC DESCRIPTION OF THE ALTERATION.

Revision	By	Appd.	YY.MM.DD	Issued	By	Appd.	YY.MM.DD

Permit-Seal

Consultants

61 Commercial St, Suite 100
Rochester, NY 14614
www.stantec.com

The Contractor shall verify and be responsible for all dimensions. DO NOT scale the drawing - any errors or omissions shall be reported to Stantec without delay.

The Copyrights to all designs and drawings are the property of Stantec. Reproduction or use for any purpose other than that authorized by Stantec is forbidden.

Client/Project
CITY OF ROCHESTER
INNER LOOP EAST TRANSFORMATION PROJECT
S. CLINTON AVENUE TO EAST MAIN STREET
P.I.N. 4940.T7 D017599
ROCHESTER, NEW YORK

File Name: _____
Dwn. Chkd. Dsgn. 14.03
YY.MM.DD

Title
GENERAL PLAN
SOUTH UNION STREET

Project No. 192500295
Scale 1" = 20'

Drawing No. GNP-2
Sheet XXX of XXX
Revision 0

Design File: U:\192500295\Transportation\Preparation\Drawings\Plan Set\PL_design_report\GNP-02.dgn
 Date/Time: 3/27/2014 8:47 AM
 Plotted By: dtabok

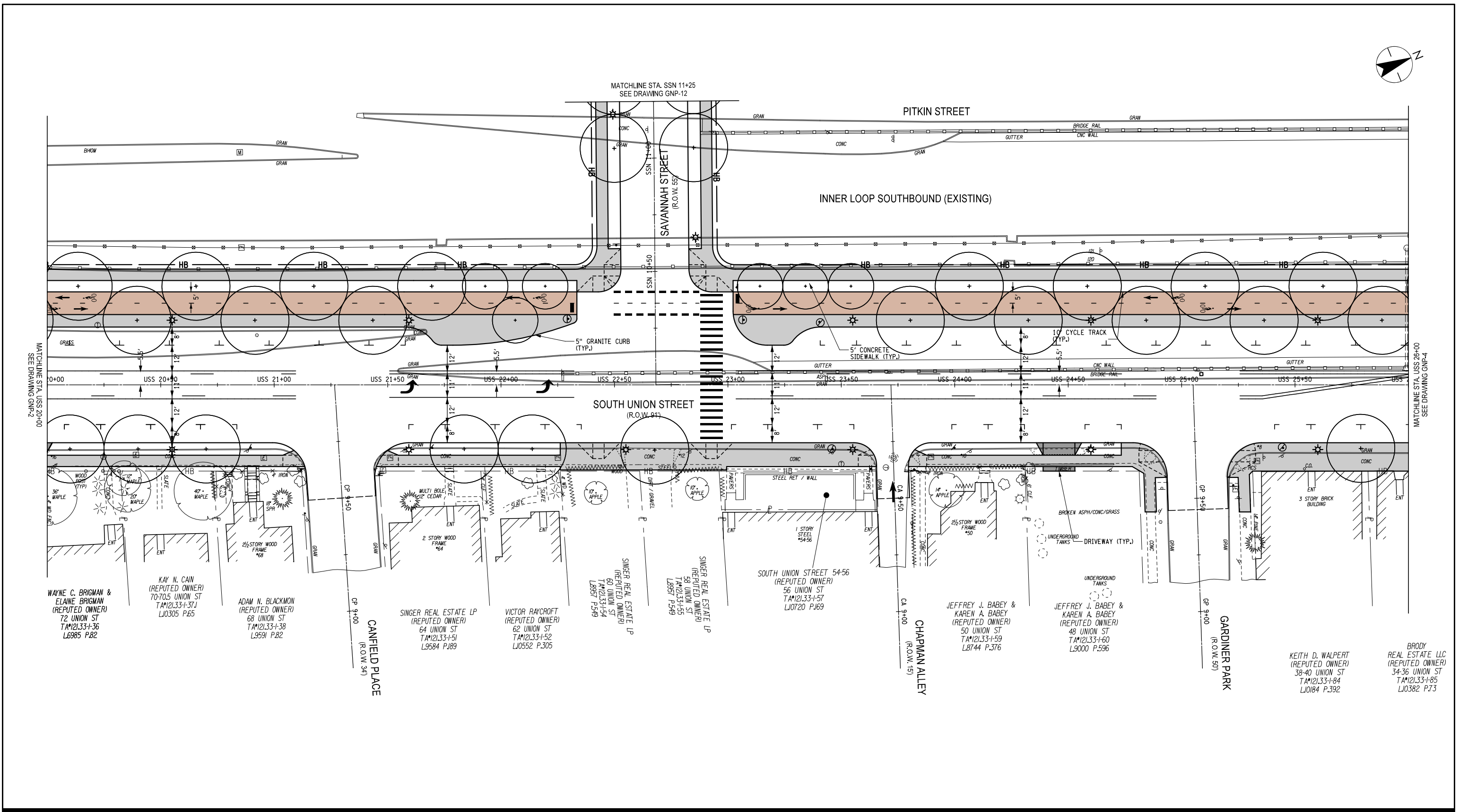

Revision	By	Appd.	YY.MM.DD	Issued	By	Appd.	YY.MM.DD

Permit-Seal	Consultants

Stantec

61 Commercial St, Suite 100
Rochester, NY 14614
www.stantec.com

The Contractor shall verify and be responsible for all dimensions. DO NOT scale the drawing - any errors or omissions shall be reported to Stantec without delay.

The Copyrights to all designs and drawings are the property of Stantec. Reproduction or use for any purpose other than that authorized by Stantec is forbidden.

Client/Project	CITY OF ROCHESTER	
INNER LOOP EAST TRANSFORMATION PROJECT S. CLINTON AVENUE TO EAST MAIN STREET P.I.N. 4940.17 D017599		
ROCHESTER, NEW YORK		
File Name:		14.03
	Dwn.	Chkd. Dsgn.

Title	GENERAL PLAN SOUTH UNION STREET		
Project No.	192500295	Scale	1" = 20'
Drawing No.	GNP-3	Sheet	XXX of XXX
		Revision	0

Design File: \\s020295\Temp\station\Pre\station\Drawings\Plan Set\Pl_Landscape\report\GNP-03.dgn
Date/Time: 3/27/2014 8:48 AM
Plotted By: gbbok

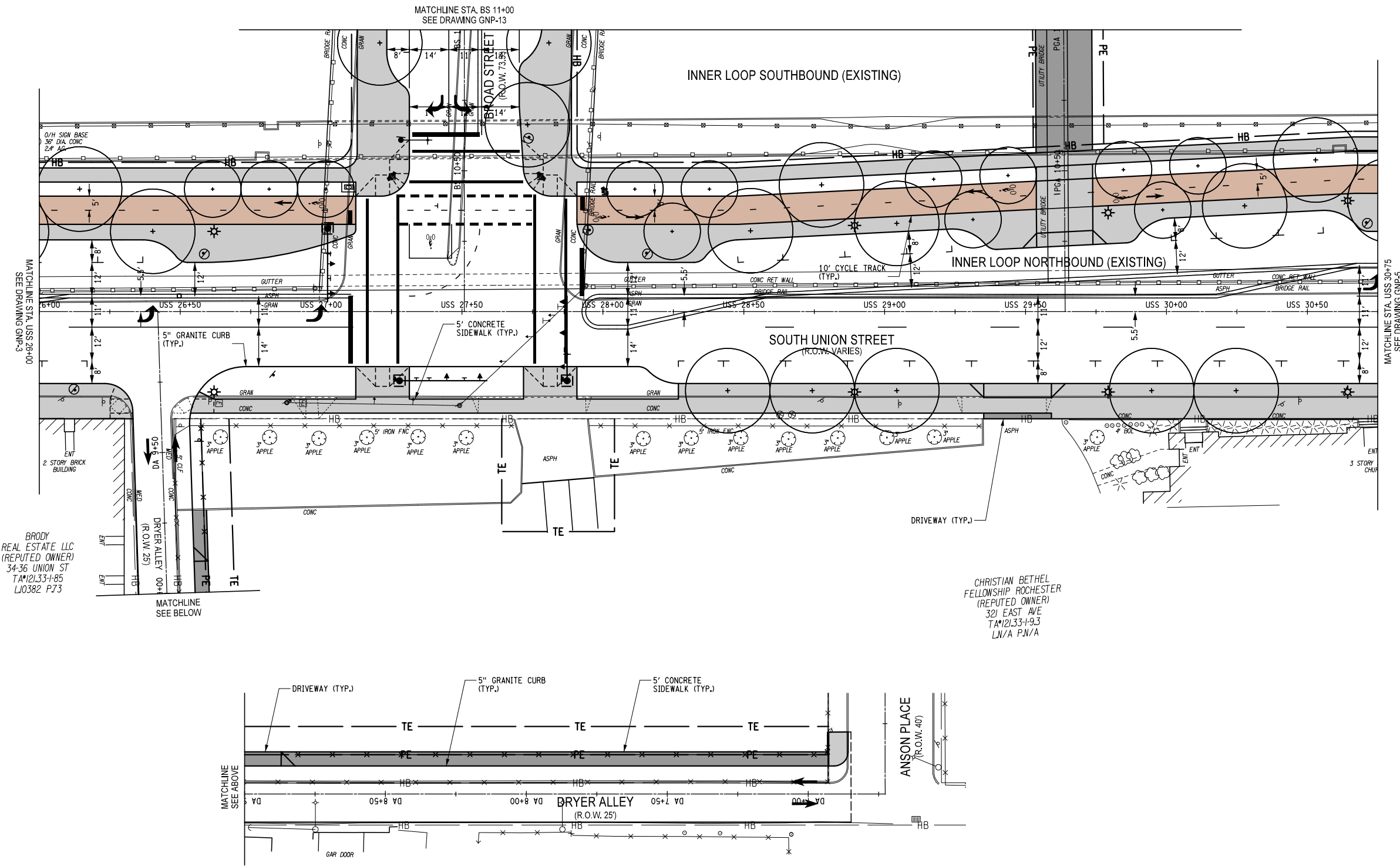

BRODY
REAL ESTATE LLC
(REPUTED OWNER)
34-36 UNION ST
TA#121.33+85
LJ0382 P.73

CHRISTIAN BETHEL
FELLOWSHIP ROCHESTER
(REPUTED OWNER)
321 EAST AVE
TA#121.33+9.3
LN/A P.N/A

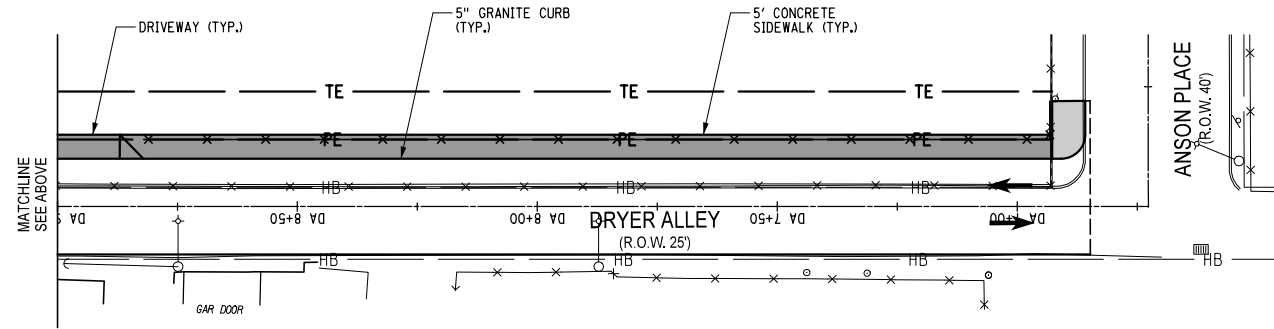

IT IS A VIOLATION OF LAW FOR ANY PERSON, UNLESS THEY ARE ACTING UNDER THE DIRECTION OF A LICENSED PROFESSIONAL ENGINEER, ARCHITECT, LANDSCAPE ARCHITECT, OR LAND SURVEYOR, TO ALTER AN ITEM IN ANY WAY. IF AN ITEM BEARING THE STAMP OF A LICENSED PROFESSIONAL IS ALTERED, THE ALTERING ENGINEER, ARCHITECT, LANDSCAPE ARCHITECT, OR LAND SURVEYOR SHALL STAMP THE DOCUMENT AND INCLUDE THE NOTATION "ALTERED BY" FOLLOWED BY THEIR SIGNATURE, THE DATE OF SUCH ALTERATION, AND A SPECIFIC DESCRIPTION OF THE ALTERATION.

Revision	By	Appd.	YY.MM.DD	Issued	By	Appd.	YY.MM.DD

Permit-Seal

Consultants



61 Commercial St, Suite 100
Rochester, NY 14614
www.stantec.com

The Contractor shall verify and be responsible for all dimensions. DO NOT scale the drawing - any errors or omissions shall be reported to Stantec without delay.
The Copyrights to all designs and drawings are the property of Stantec. Reproduction or use for any purpose other than that authorized by Stantec is forbidden.

Client/Project
CITY OF ROCHESTER
INNER LOOP EAST TRANSFORMATION PROJECT
S. CLINTON AVENUE TO EAST MAIN STREET
P.I.N. 4940.T7 D017599
ROCHESTER, NEW YORK

File Name: _____
Dwn. Chkd. Dsgn. 14.03
YY.MM.DD

Title
GENERAL PLAN
SOUTH UNION STREET
Project No. 192500295
Scale 1' = 20'
Drawing No. GNP-4
Sheet XXX of XXX
Revision 0

Design File: U:\192500295\Transportation\Preliminary\Drawings\Plan Set\PL_design report\GNP-04.dgn
 Date Plotted: 3/27/2014 8:16:49 AM
 Plotted By: dtabak

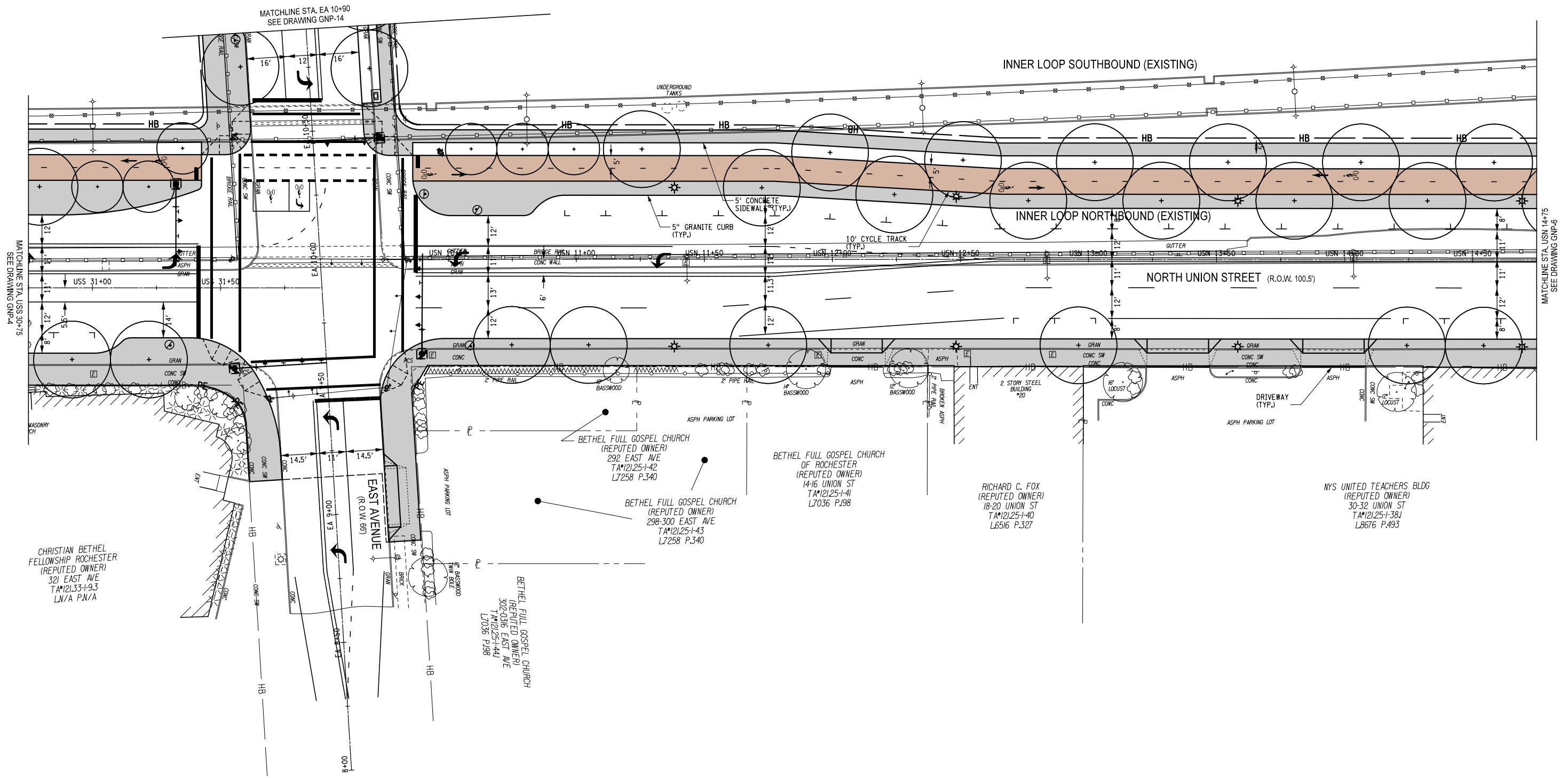

Design File: I:\20250295\Transportation\Preparation\Drawings\Plan Set\PLDesign report\GNP-05.dgn
 Date/Time: 3/27/2024 8:45 AM
 Plotted By: dtabok

IT IS A VIOLATION OF LAW FOR ANY PERSON, UNLESS THEY ARE ACTING UNDER THE DIRECTION OF A LICENSED PROFESSIONAL ENGINEER, ARCHITECT, LANDSCAPE ARCHITECT, OR LAND SURVEYOR, TO ALTER AN ITEM IN ANY WAY. IF AN ITEM BEARING THE STAMP OF A LICENSED PROFESSIONAL IS ALTERED, THE ALTERING ENGINEER, ARCHITECT, LANDSCAPE ARCHITECT, OR LAND SURVEYOR SHALL STAMP THE DOCUMENT AND INCLUDE THE NOTATION "ALTERED BY" FOLLOWED BY THEIR SIGNATURE, THE DATE OF SUCH ALTERATION, AND A SPECIFIC DESCRIPTION OF THE ALTERATION.			
Revision	By	Appd.	Issued

Permit-Seal

Consultants

61 Commercial St, Suite 100
 Rochester, NY 14614
 www.stantec.com

The Contractor shall verify and be responsible for all dimensions. DO NOT scale the drawing - any errors or omissions shall be reported to Stantec without delay.

The Copyrights to all designs and drawings are the property of Stantec. Reproduction or use for any purpose other than that authorized by Stantec is forbidden.

Client/Project	CITY OF ROCHESTER
	INNER LOOP EAST TRANSFORMATION PROJECT S. CLINTON AVENUE TO EAST MAIN STREET P.I.N. 4940.T7 D017599
	ROCHESTER, NEW YORK
File Name:	14.03 YY.MM.DD
Dwn.	Chkd.
Dsgn.	

Title	GENERAL PLAN SOUTH UNION STREET	
Project No.	Scale	1' = 20'
192500295	Sheet	Revision
Drawing No.	GNP-5	XXX of XXX
		0

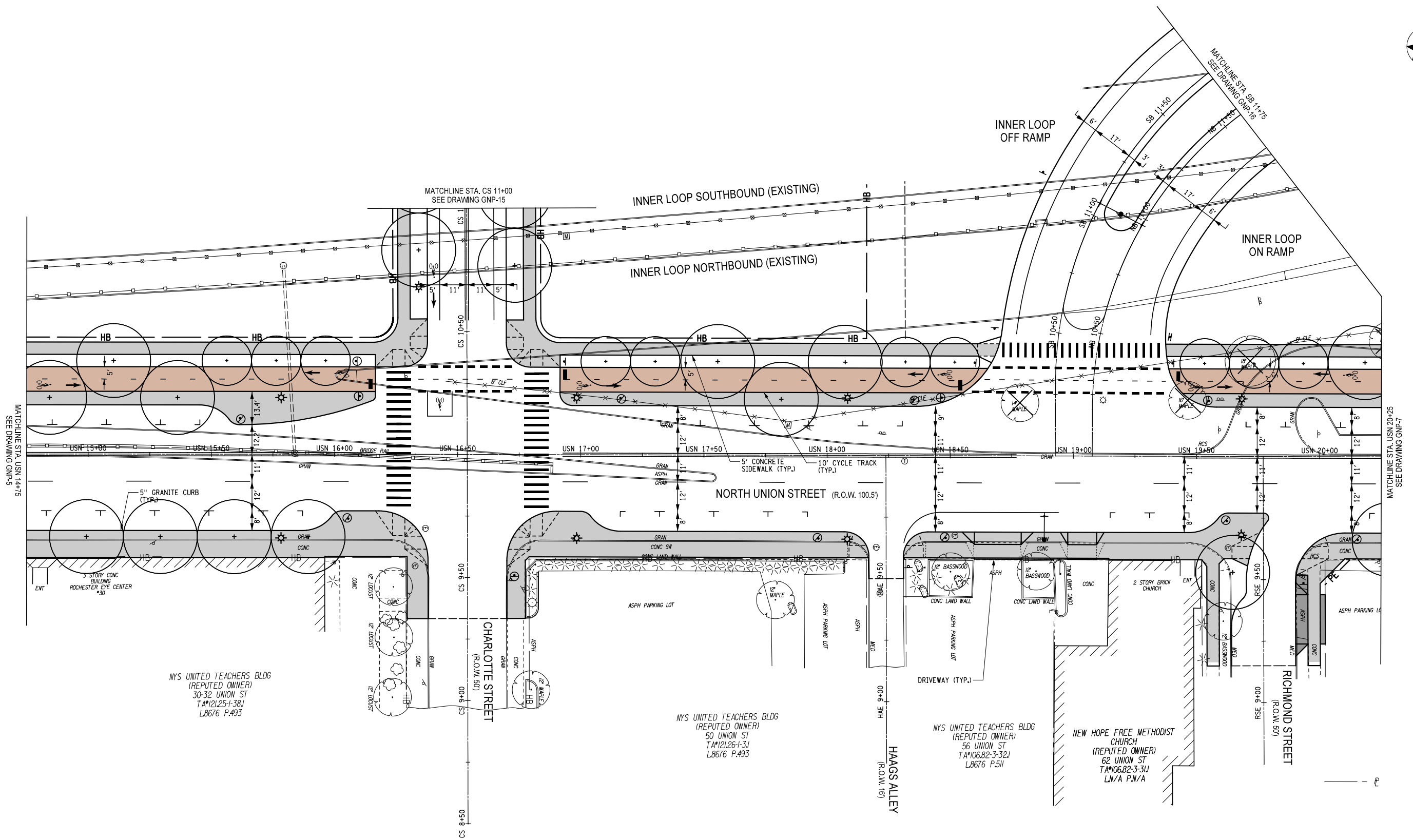

IT IS A VIOLATION OF LAW FOR ANY PERSON, UNLESS THEY ARE ACTING UNDER THE DIRECTION OF A LICENSED PROFESSIONAL ENGINEER, ARCHITECT, LANDSCAPE ARCHITECT, OR LAND SURVEYOR, TO ALTER AN ITEM IN ANY WAY. IF AN ITEM BEARING THE STAMP OF A LICENSED PROFESSIONAL IS ALTERED, THE ALTERING ENGINEER, ARCHITECT, LANDSCAPE ARCHITECT, OR LAND SURVEYOR SHALL STAMP THE DOCUMENT AND INCLUDE THE NOTATION "ALTERED BY" FOLLOWED BY THEIR SIGNATURE, THE DATE OF SUCH ALTERATION, AND A SPECIFIC DESCRIPTION OF THE ALTERATION.

Revision	By	Appd.	YY.MM.DD	Issued	By	Appd.	YY.MM.DD

Permit-Seal

Consultants



61 Commercial St, Suite 100
Rochester, NY 14614
www.stantec.com

The Contractor shall verify and be responsible for all dimensions. DO NOT scale the drawing - any errors or omissions shall be reported to Stantec without delay.
The Copyrights to all designs and drawings are the property of Stantec. Reproduction or use for any purpose other than that authorized by Stantec is forbidden.

Client/Project
CITY OF ROCHESTER
INNER LOOP EAST TRANSFORMATION PROJECT
S. CLINTON AVENUE TO EAST MAIN STREET
P.I.N. 4940.T7 D017599
ROCHESTER, NEW YORK

File Name: _____
Dwn. Chkd. Dsgn. 14.03
YY.MM.DD

Title
GENERAL PLAN
SOUTH UNION STREET

Project No. 192500295
Scale 1' = 20'

Drawing No. GNP-6
Sheet XXX of XXX
Revision 0

Design File: I:\202500295\Transportation\Drawings\Plan Set\PL_design report\GNP-06.dgn
 Date Plotted: 3/27/2024 at 6:51 AM
 Plotted By: gbbok

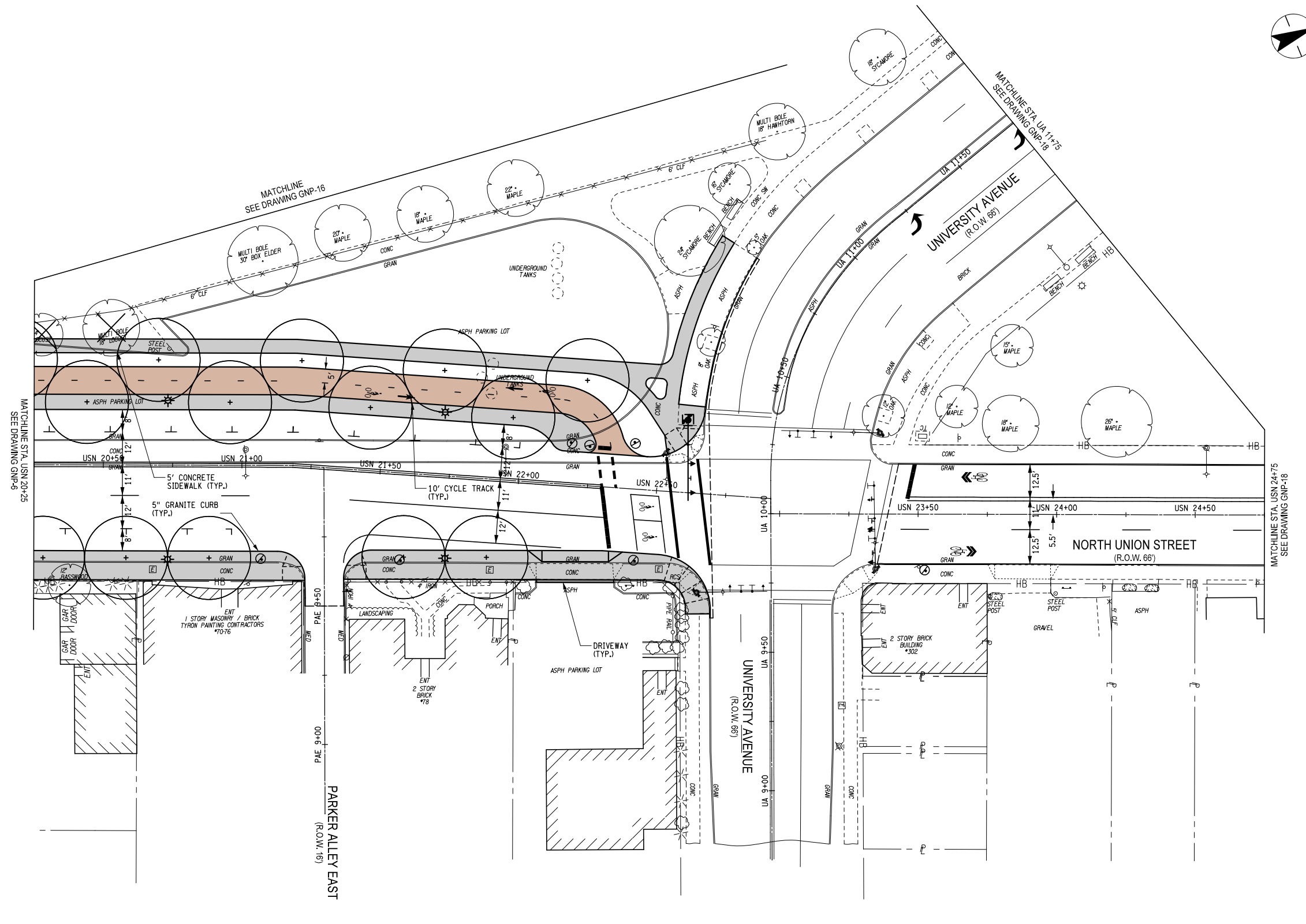

IT IS A VIOLATION OF LAW FOR ANY PERSON, UNLESS THEY ARE ACTING UNDER THE DIRECTION OF A LICENSED PROFESSIONAL ENGINEER, ARCHITECT, LANDSCAPE ARCHITECT, OR LAND SURVEYOR, TO ALTER AN ITEM IN ANY WAY. IF AN ITEM BEARING THE STAMP OF A LICENSED PROFESSIONAL IS ALTERED, THE ALTERING ENGINEER, ARCHITECT, LANDSCAPE ARCHITECT, OR LAND SURVEYOR SHALL STAMP THE DOCUMENT AND INCLUDE THE NOTATION "ALTERED BY" FOLLOWED BY THEIR SIGNATURE, THE DATE OF SUCH ALTERATION, AND A SPECIFIC DESCRIPTION OF THE ALTERATION.

Revision	By	Appd.	YY.MM.DD	Issued	By	Appd.	YY.MM.DD

Permit-Seal
 Consultants
 Client/Project
CITY OF ROCHESTER
 INNER LOOP EAST TRANSFORMATION PROJECT
 S. CLINTON AVENUE TO EAST MAIN STREET
 P.I.N. 4940.17 D017599
 ROCHESTER, NEW YORK



61 Commercial St. Suite 100
 Rochester, NY 14614
 www.stantec.com

The Contractor shall verify and be responsible for all dimensions. DO NOT scale the drawing - any errors or omissions shall be reported to Stantec without delay.

The Copyrights to all designs and drawings are the property of Stantec. Reproduction or use for any purpose other than that authorized by Stantec is forbidden.

Title
**GENERAL PLAN
 SOUTH UNION STREET**

Project No. 192500295
 Scale 1' = 20'

Drawing No. GNP-7
 Sheet XXX of XXX
 Revision 0

File Name: _____
 Dwn. _____ Chkd. _____ Dsgn. _____ 14.03
 YY.MM.DD

Design File: I:\192500295\Technical\Drawings\Plan Set\PL_design_report\GNP-07.dgn
 Date/Time: 3/27/2014 8:17:08 AM
 Plotted By: gtabak

ORIGINAL SHEET - ANSID HOMI



ESL FEDERAL CREDIT UNION
(REPUTED OWNER)
280 S CLINTON AV
T*12/140-1125
L10634 P.266

STATE OF
NEW YORK
(REPUTED OWNER)
LN/A P.N/A

STATE OF
NEW YORK
(REPUTED OWNER)
LN/A P.N/A

CITY OF ROCHESTER
(REPUTED OWNER)
40 MARSHALL ST
T*12/140-2-1
LN/A P.N/A

CITY OF ROCHESTER
(REPUTED OWNER)
48 MARSHALL ST
T*12/140-2-2
LN/A P.N/A

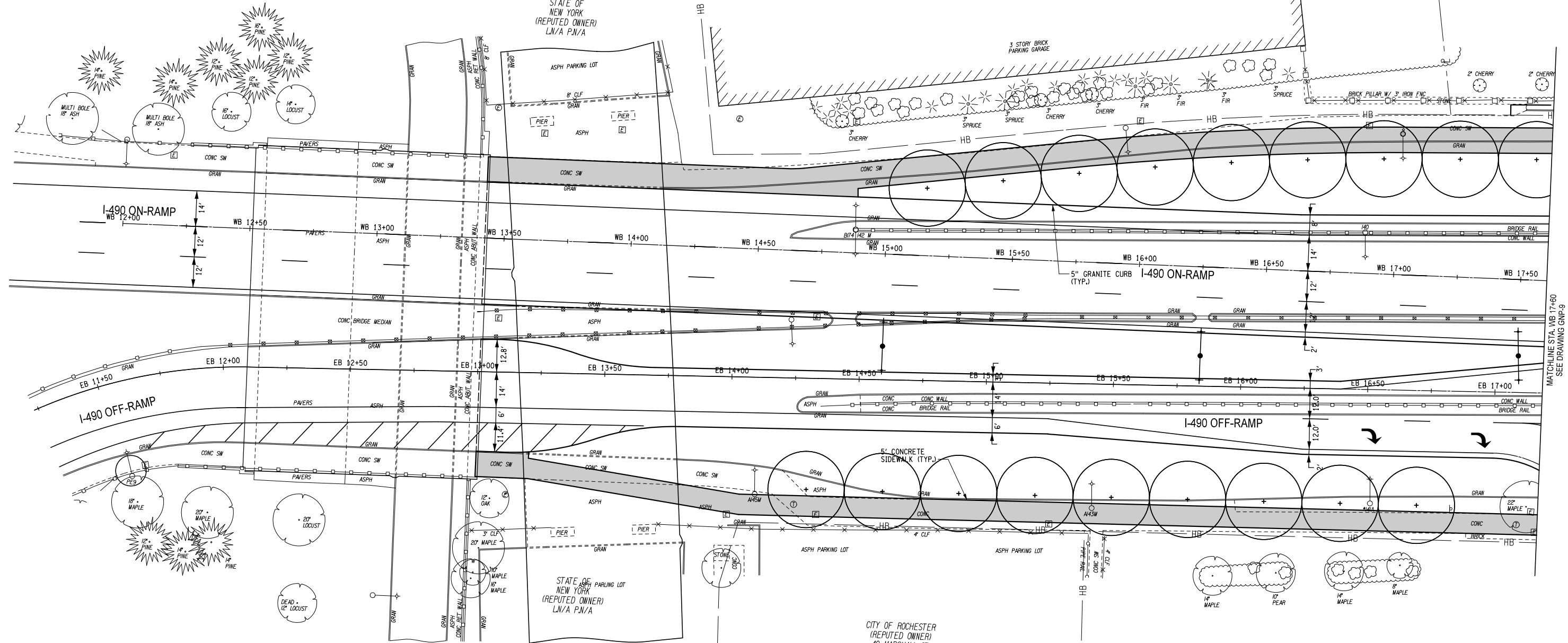

MATCHLINE STA. WB 17+80
SEE DRAWING GNP-9

IT IS A VIOLATION OF LAW FOR ANY PERSON, UNLESS THEY ARE ACTING UNDER THE DIRECTION OF A LICENSED PROFESSIONAL ENGINEER, ARCHITECT, LANDSCAPE ARCHITECT, OR LAND SURVEYOR, TO ALTER AN ITEM IN ANY WAY. IF AN ITEM BEARING THE STAMP OF A LICENSED PROFESSIONAL IS ALTERED, THE ALTERING ENGINEER, ARCHITECT, LANDSCAPE ARCHITECT, OR LAND SURVEYOR SHALL STAMP THE DOCUMENT AND INCLUDE THE NOTATION "ALTERED BY" FOLLOWED BY THEIR SIGNATURE, THE DATE OF SUCH ALTERATION, AND A SPECIFIC DESCRIPTION OF THE ALTERATION.

Revision	By	Appd.	YY.MM.DD	Issued	By	Appd.	YY.MM.DD

Permit-Seal

Consultants

Stantec

61 Commercial St. Suite 100
Rochester, NY 14614
www.stantec.com

The Contractor shall verify and be responsible for all dimensions. DO NOT scale the drawing - any errors or omissions shall be reported to Stantec without delay.

The Copyrights to all designs and drawings are the property of Stantec. Reproduction or use for any purpose other than that authorized by Stantec is forbidden.

Client/Project
CITY OF ROCHESTER
INNER LOOP EAST TRANSFORMATION PROJECT
S. CLINTON AVENUE TO EAST MAIN STREET
P.I.N. 4940.T7 D017599
ROCHESTER, NEW YORK

File Name: _____

Title	Project No.	Scale
GENERAL PLAN	192500295	1" = 20'
Drawing No.	Sheet	Revision
GNP-8	XXX of XXX	0

Design File: I:\9250295\Terrain\Plan\14614\14614.dwg
Date/Time: 3/27/2014 8:17:10 AM
Plotted By: ddbak

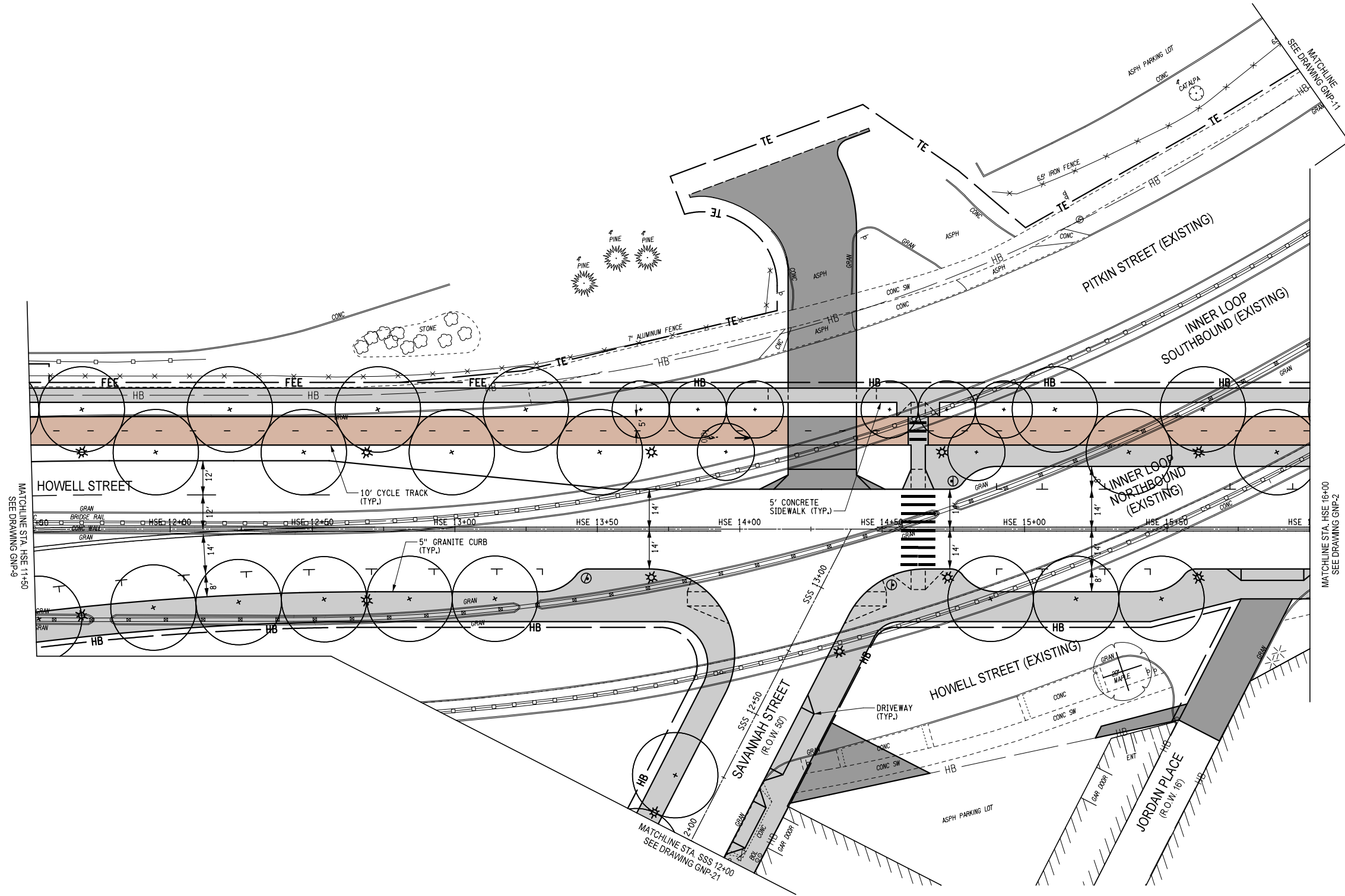

IT IS A VIOLATION OF LAW FOR ANY PERSON, UNLESS THEY ARE ACTING UNDER THE DIRECTION OF A LICENSED PROFESSIONAL ENGINEER, ARCHITECT, LANDSCAPE ARCHITECT, OR LAND SURVEYOR, TO ALTER AN ITEM IN ANY WAY. IF AN ITEM BEARING THE STAMP OF A LICENSED PROFESSIONAL IS ALTERED, THE ALTERING ENGINEER, ARCHITECT, LANDSCAPE ARCHITECT, OR LAND SURVEYOR SHALL STAMP THE DOCUMENT AND INCLUDE THE NOTATION "ALTERED BY" FOLLOWED BY THEIR SIGNATURE, THE DATE OF SUCH ALTERATION, AND A SPECIFIC DESCRIPTION OF THE ALTERATION.

Permit-Seal

Consultants



61 Commercial St. Suite 100
Rochester, NY 14614
www.stantec.com

The Contractor shall verify and be responsible for all dimensions. DO NOT scale the drawing - any errors or omissions shall be reported to Stantec without delay.

The Copyrights to all designs and drawings are the property of Stantec. Reproduction or use for any purpose other than that authorized by Stantec is forbidden.

Client/Project

CITY OF ROCHESTER

INNER LOOP EAST TRANSFORMATION PROJECT
S. CLINTON AVENUE TO EAST MAIN STREET
P.I.N. 4940.T7 D017599

ROCHESTER, NEW YORK

File Name: _____ Dwn. Chkd. Dsgn. 14.03
YY.MM.DD

Title

GENERAL PLAN

Project No.
192500295

Scale
1' = 20'

Drawing No.

Sheet

Revision

GNP-10

XXX of XXX

0

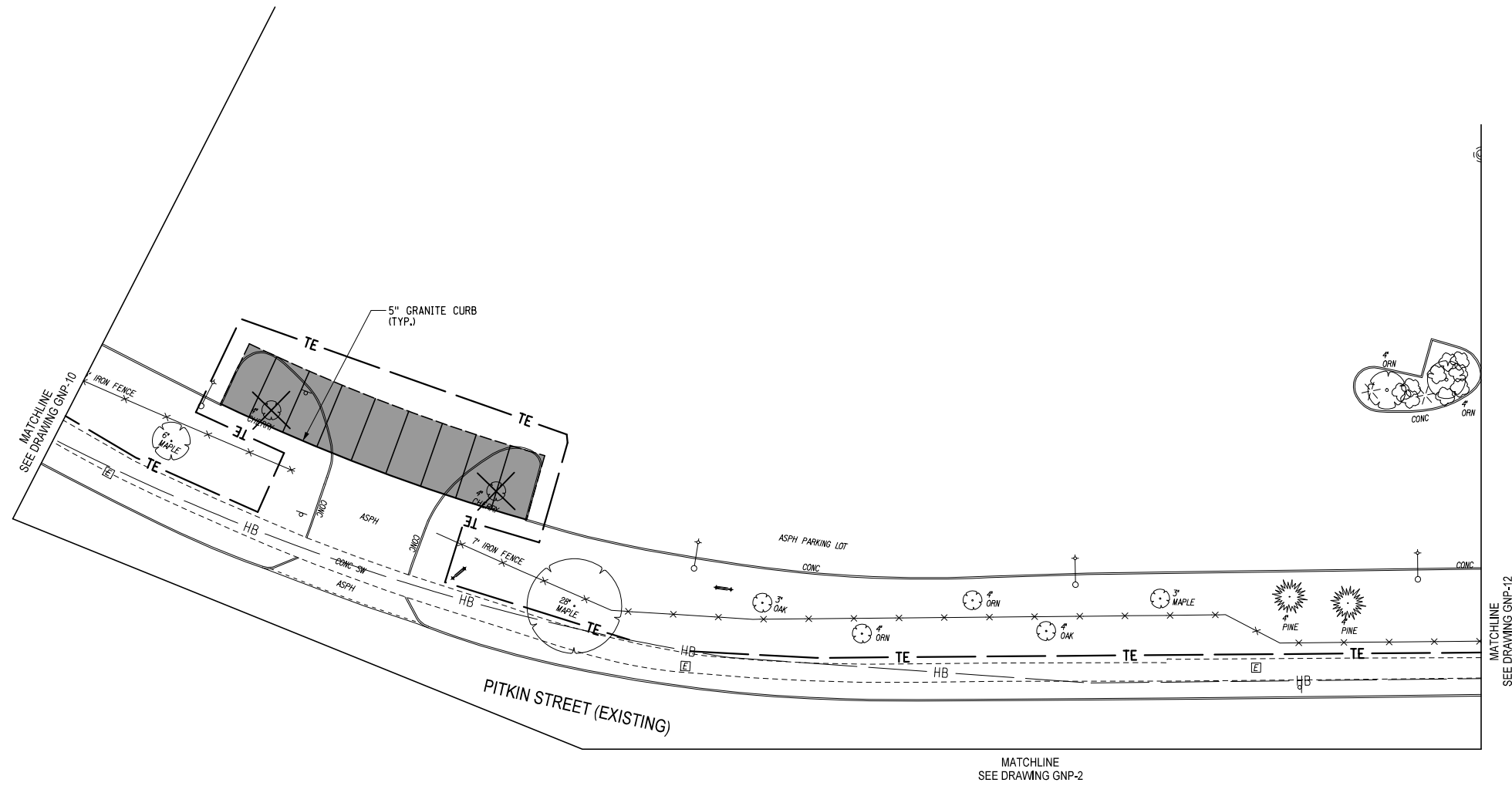

IT IS A VIOLATION OF LAW FOR ANY PERSON, UNLESS THEY ARE ACTING UNDER THE DIRECTION OF A LICENSED PROFESSIONAL ENGINEER, ARCHITECT, LANDSCAPE ARCHITECT, OR LAND SURVEYOR, TO ALTER AN ITEM IN ANY WAY. IF AN ITEM BEARING THE STAMP OF A LICENSED PROFESSIONAL IS ALTERED, THE ALTERING ENGINEER, ARCHITECT, LANDSCAPE ARCHITECT, OR LAND SURVEYOR SHALL STAMP THE DOCUMENT AND INCLUDE THE NOTATION "ALTERED BY" FOLLOWED BY THEIR SIGNATURE, THE DATE OF SUCH ALTERATION, AND A SPECIFIC DESCRIPTION OF THE ALTERATION.

Permit-Seal

Consultants



61 Commercial St, Suite 100
Rochester, NY 14614
www.stantec.com

The Contractor shall verify and be responsible for all dimensions. DO NOT scale the drawing - any errors or omissions shall be reported to Stantec without delay.
The Copyrights to all designs and drawings are the property of Stantec. Reproduction or use for any purpose other than that authorized by Stantec is forbidden.

Client/Project
CITY OF ROCHESTER

INNER LOOP EAST TRANSFORMATION PROJECT
S. CLINTON AVENUE TO EAST MAIN STREET
P.I.N. 4940.T7 D017599

ROCHESTER, NEW YORK

File Name: _____
Dwn. Chkd. Dsgn. 14.03
YY.MM.DD

Title
GENERAL PLAN
PITKIN STREET

Project No. 192500295
Scale 1" = 20'

Drawing No. GNP-11
Sheet XXX of XXX
Revision 0

Revision	By	Appd.	YY.MM.DD	Issued	By	Appd.	YY.MM.DD

Design File: U:\192500295\Temporary\Drawings\Plan Set\PL_design report\GNP-11.dgn
 Date Plotted: 3/27/2014 8:17:15 AM
 Plotted By: gbbok

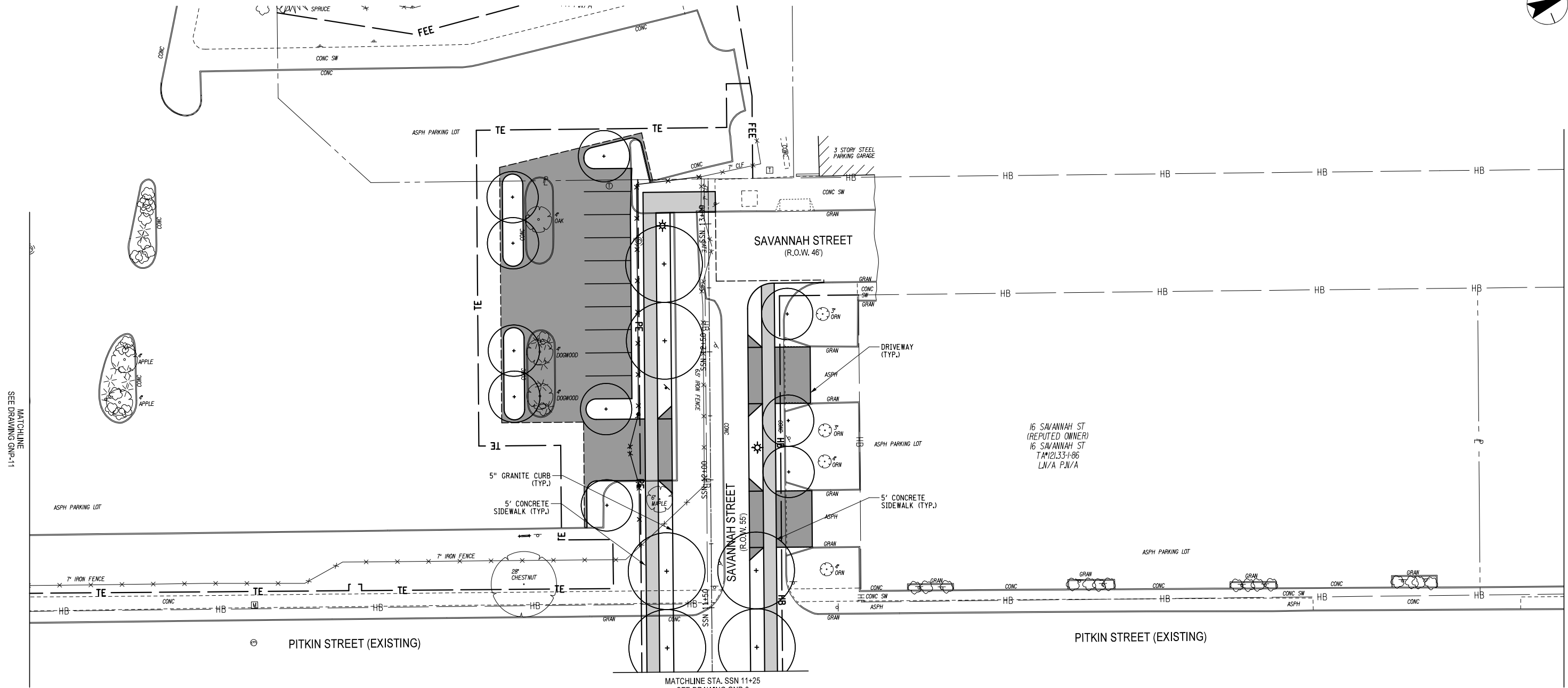
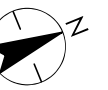

MATCHLINE SEE DRAWING GNP-11

MATCHLINE SEE DRAWING GNP-13

PITKIN STREET (EXISTING)

MATCHLINE STA. SSN 11+25
SEE DRAWING GNP-3

16 SAVANNAH ST
(REPUTED OWNER)
16 SAVANNAH ST
TAM 21.33+86
LN/A P.N/A

IT IS A VIOLATION OF LAW FOR ANY PERSON, UNLESS THEY ARE ACTING UNDER THE DIRECTION OF A LICENSED PROFESSIONAL ENGINEER, ARCHITECT, LANDSCAPE ARCHITECT, OR LAND SURVEYOR, TO ALTER AN ITEM IN ANY WAY. IF AN ITEM BEARING THE STAMP OF A LICENSED PROFESSIONAL IS ALTERED, THE ALTERING ENGINEER, ARCHITECT, LANDSCAPE ARCHITECT, OR LAND SURVEYOR SHALL STAMP THE DOCUMENT AND INCLUDE THE NOTATION "ALTERED BY" FOLLOWED BY THEIR SIGNATURE, THE DATE OF SUCH ALTERATION, AND A SPECIFIC DESCRIPTION OF THE ALTERATION.			
Revision	By	Appd.	YY.MM.DD

Permit-Seal

Consultants



61 Commercial St. Suite 100
Rochester, NY 14614
www.stantec.com

The Contractor shall verify and be responsible for all dimensions. DO NOT scale the drawing - any errors or omissions shall be reported to Stantec without delay.

The Copyrights to all designs and drawings are the property of Stantec. Reproduction or use for any purpose other than that authorized by Stantec is forbidden.

Client/Project	CITY OF ROCHESTER
	INNER LOOP EAST TRANSFORMATION PROJECT S. CLINTON AVENUE TO EAST MAIN STREET P.I.N. 4940.T7 D017599
	ROCHESTER, NEW YORK
File Name:	14.03 YY.MM.DD
	Dwn. Chkd. Dsgn.

Title	
GENERAL PLAN PITKIN STREET	
Project No.	Scale
192500295	1' = 20'
Drawing No.	Sheet
GNP-12	XXX of XXX
	Revision
	0

Design File: U:\192500295\Temporary\Drawings\Plan Set\PL_design report\GNP-12.dgn
Date/Time: 3/27/2014 8:17:16 AM
Plotted By: dtabak

ORIGINAL SHEET - NOT TO SCALE

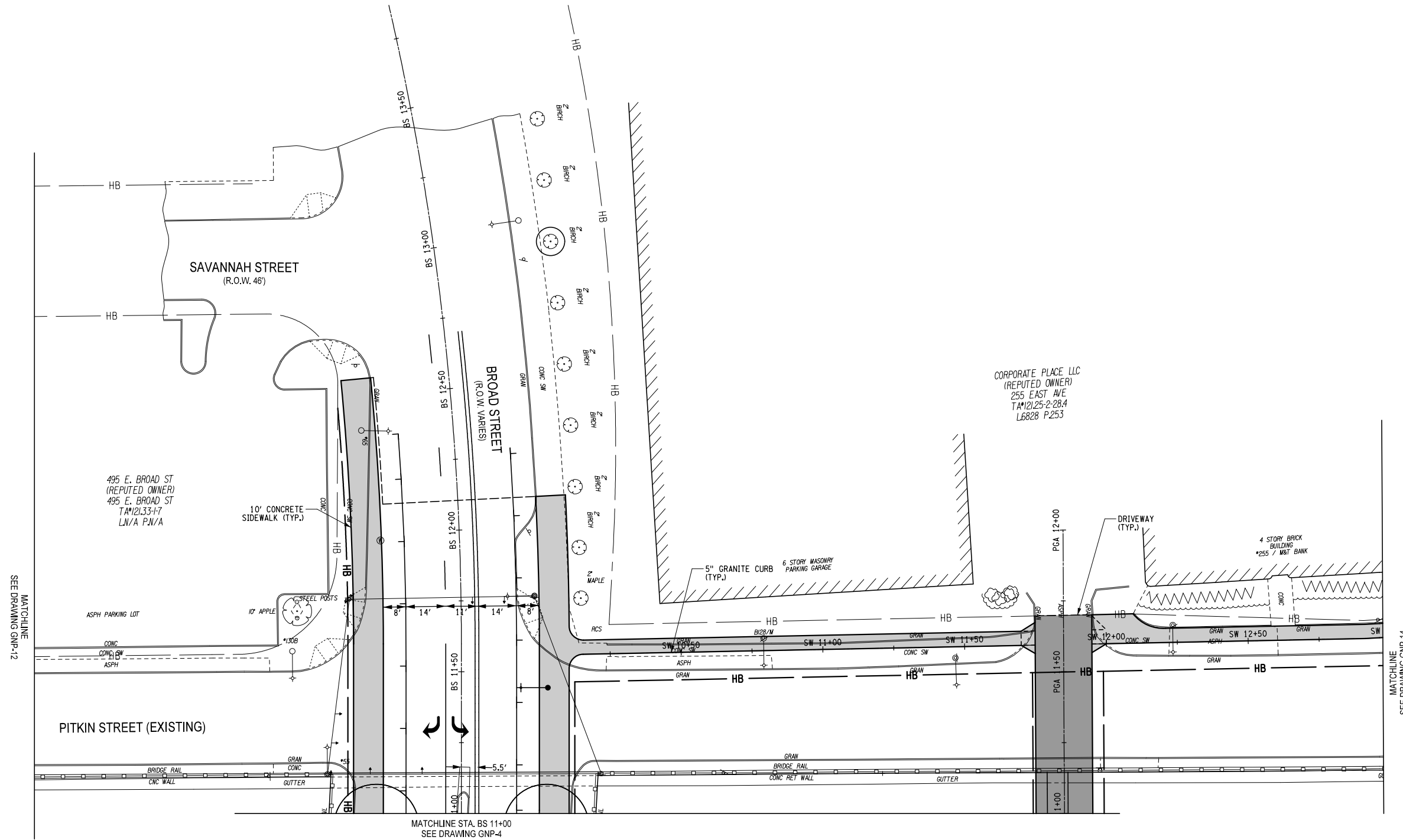

IT IS A VIOLATION OF LAW FOR ANY PERSON, UNLESS THEY ARE ACTING UNDER THE DIRECTION OF A LICENSED PROFESSIONAL ENGINEER, ARCHITECT, LANDSCAPE ARCHITECT, OR LAND SURVEYOR, TO ALTER AN ITEM IN ANY WAY. IF AN ITEM BEARING THE STAMP OF A LICENSED PROFESSIONAL IS ALTERED, THE ALTERING ENGINEER, ARCHITECT, LANDSCAPE ARCHITECT, OR LAND SURVEYOR SHALL STAMP THE DOCUMENT AND INCLUDE THE NOTATION "ALTERED BY" FOLLOWED BY THEIR SIGNATURE, THE DATE OF SUCH ALTERATION, AND A SPECIFIC DESCRIPTION OF THE ALTERATION.

Permit-Seal

Consultants



61 Commercial St, Suite 100
Rochester, NY 14614
www.stantec.com

The Contractor shall verify and be responsible for all dimensions. DO NOT scale the drawing - any errors or omissions shall be reported to Stantec without delay.
The Copyrights to all designs and drawings are the property of Stantec. Reproduction or use for any purpose other than that authorized by Stantec is forbidden.

Client/Project

CITY OF ROCHESTER
INNER LOOP EAST TRANSFORMATION PROJECT
S. CLINTON AVENUE TO EAST MAIN STREET
P.I.N. 4940.T7 D017599
ROCHESTER, NEW YORK

Title

GENERAL PLAN
PITKIN STREET

Project No.
192500295

Drawing No.
GNP-13

Scale
1" = 20'

Sheet
XXX of XXX

Revision
0

File Name: _____
Dwn. Chkd. Dsgn. 14.03
YY.MM.DD

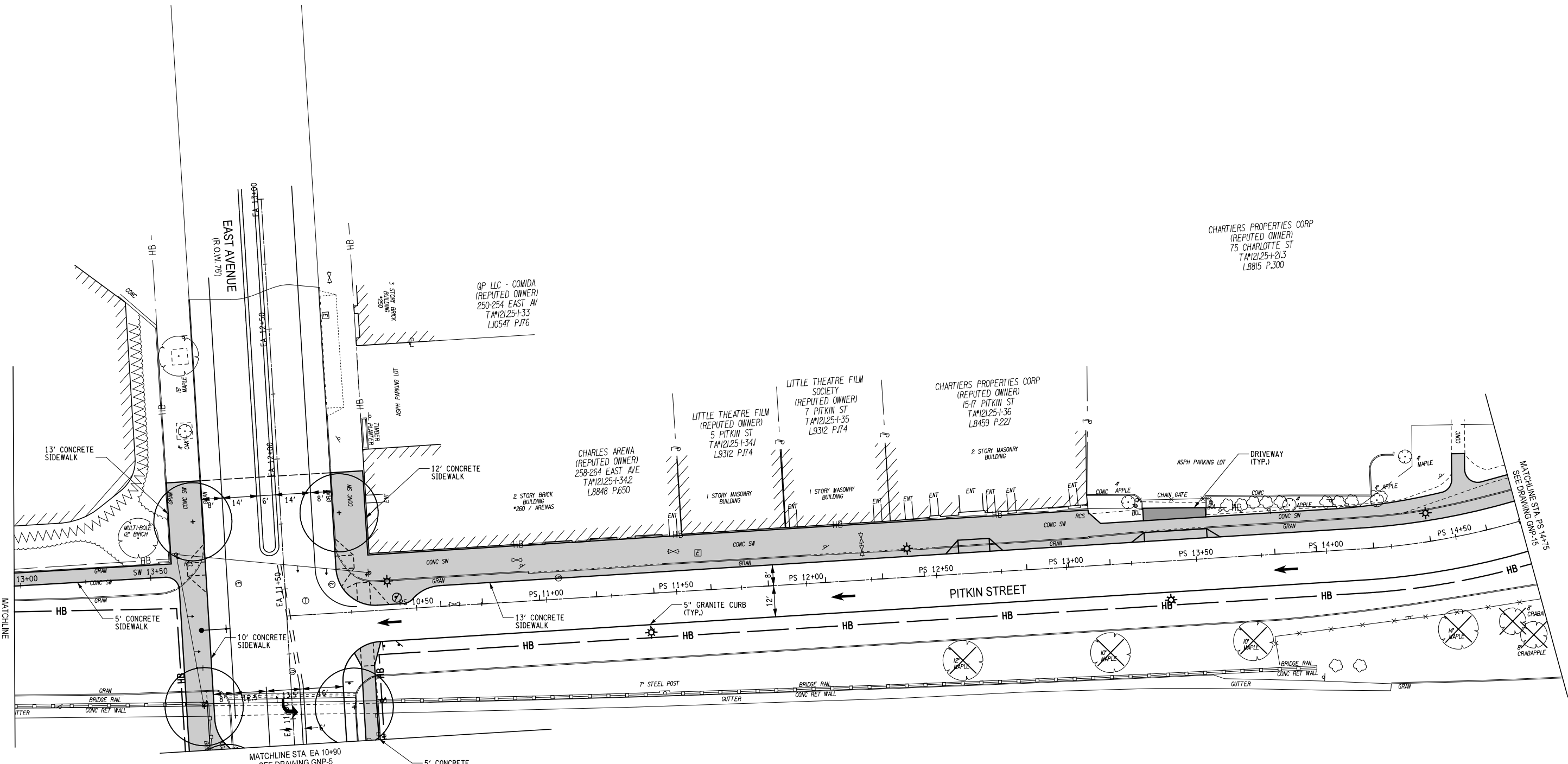

IT IS A VIOLATION OF LAW FOR ANY PERSON, UNLESS THEY ARE ACTING UNDER THE DIRECTION OF A LICENSED PROFESSIONAL ENGINEER, ARCHITECT, LANDSCAPE ARCHITECT, OR LAND SURVEYOR, TO ALTER AN ITEM IN ANY WAY. IF AN ITEM BEARING THE STAMP OF A LICENSED PROFESSIONAL IS ALTERED, THE ALTERING ENGINEER, ARCHITECT, LANDSCAPE ARCHITECT, OR LAND SURVEYOR SHALL STAMP THE DOCUMENT AND INCLUDE THE NOTATION "ALTERED BY" FOLLOWED BY THEIR SIGNATURE, THE DATE OF SUCH ALTERATION, AND A SPECIFIC DESCRIPTION OF THE ALTERATION.

Revision	By	Appd.	YY.MM.DD	Issued	By	Appd.	YY.MM.DD

Permit-Seal	Consultants
-------------	-------------



Stantec

61 Commercial St., Suite 100
Rochester, NY 14614
www.stantec.com

The Contractor shall verify and be responsible for all dimensions. DO NOT scale the drawing - any errors or omissions shall be reported to Stantec without delay.

The Copyrights to all designs and drawings are the property of Stantec. Reproduction or use for any purpose other than that authorized by Stantec is forbidden.

Client/Project
CITY OF ROCHESTER

INNER LOOP EAST TRANSFORMATION PROJECT
S. CLINTON AVENUE TO EAST MAIN STREET
P.I.N. 4940.T7 D017599

ROCHESTER, NEW YORK

File Name: _____
Dwn. Chkd. Dsgn. 14.03 YY.MM.DD

Title
GENERAL PLAN
PITKIN STREET

Project No. 192500295 Scale 1" = 20'

Drawing No. GNP-14 Sheet XXX of XXX Revision 0

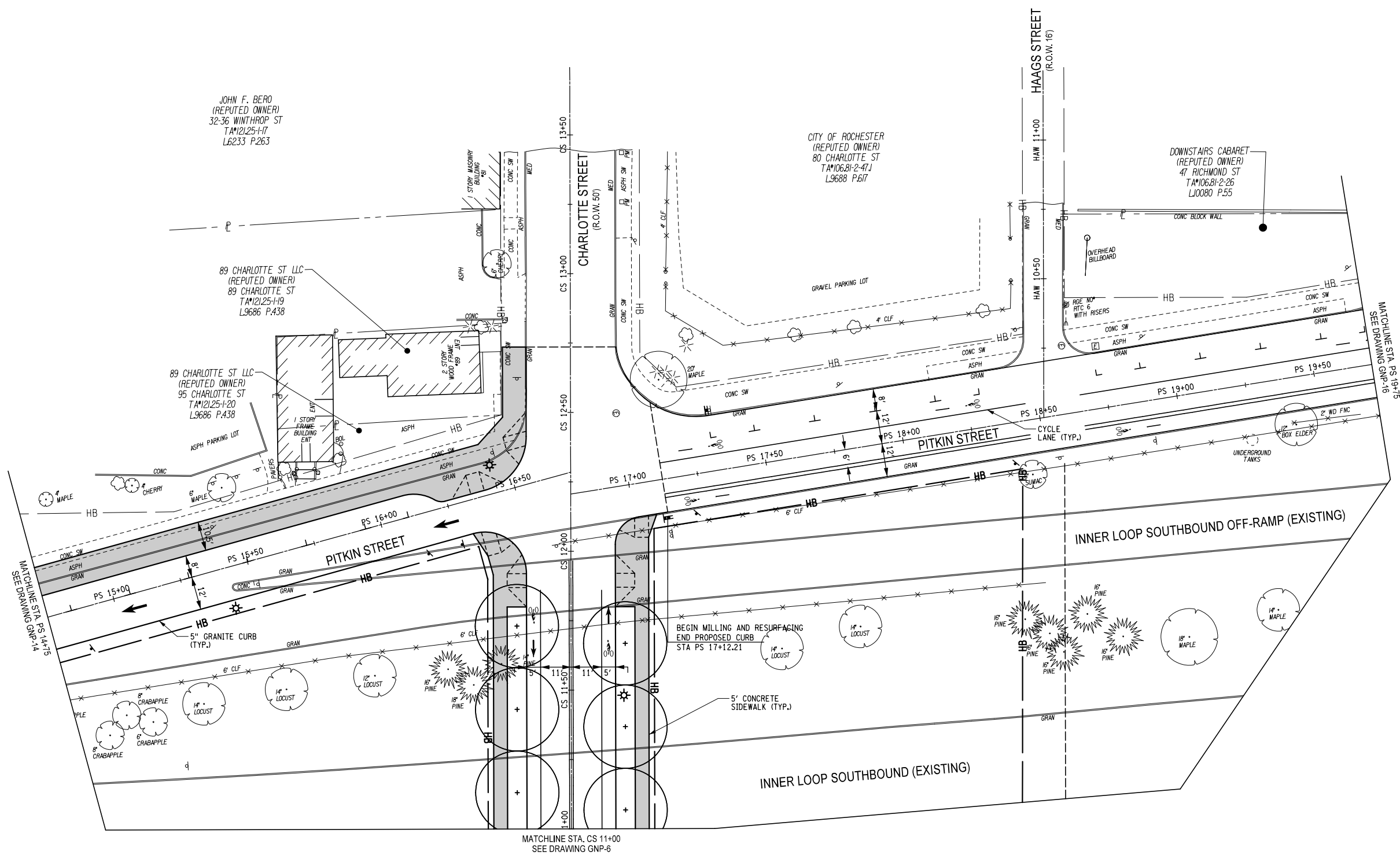

JOHN F. BERO
(REPUTED OWNER)
32-36 WINTHROP ST
TA12125-117
L96233 P.263

89 CHARLOTTE ST LLC
(REPUTED OWNER)
89 CHARLOTTE ST
TA12125-119
L9686 P.438

89 CHARLOTTE ST LLC
(REPUTED OWNER)
95 CHARLOTTE ST
TA12125-120
L9686 P.438

CITY OF ROCHESTER
(REPUTED OWNER)
80 CHARLOTTE ST
TA10681-2-47J
L9688 P.617

DOWNSTAIRS CABARET
(REPUTED OWNER)
47 RICHMOND ST
TA10681-2-26
L10080 P.55

IT IS A VIOLATION OF LAW FOR ANY PERSON, UNLESS THEY ARE ACTING UNDER THE DIRECTION OF A LICENSED PROFESSIONAL ENGINEER, ARCHITECT, LANDSCAPE ARCHITECT, OR LAND SURVEYOR, TO ALTER AN ITEM IN ANY WAY. IF AN ITEM BEARING THE STAMP OF A LICENSED PROFESSIONAL IS ALTERED, THE ALTERING ENGINEER, ARCHITECT, LANDSCAPE ARCHITECT, OR LAND SURVEYOR SHALL STAMP THE DOCUMENT AND INCLUDE THE NOTATION "ALTERED BY" FOLLOWED BY THEIR SIGNATURE, THE DATE OF SUCH ALTERATION, AND A SPECIFIC DESCRIPTION OF THE ALTERATION.

Revision	By	Appd.	YY.MM.DD	Issued	By	Appd.	YY.MM.DD

Permit-Seal	Consultants



61 Commercial St, Suite 100
Rochester, NY 14614
www.stantec.com

The Contractor shall verify and be responsible for all dimensions. DO NOT scale the drawing - any errors or omissions shall be reported to Stantec without delay.

The Copyrights to all designs and drawings are the property of Stantec. Reproduction or use for any purpose other than that authorized by Stantec is forbidden.

Client/Project	
CITY OF ROCHESTER	
INNER LOOP EAST TRANSFORMATION PROJECT	
S. CLINTON AVENUE TO EAST MAIN STREET	
P.I.N. 4940.T7 D017599	
ROCHESTER, NEW YORK	
File Name:	14.03 YY.MM.DD

Title		
GENERAL PLAN		
PITKIN STREET		
Project No.	Scale	
192500295	1" = 20'	
Drawing No.	Sheet	Revision
GNP-15	XXX of XXX	0

Design File: U:\192500295\Technical\Plan\GNP-15.dgn
 Date/Time: 3/27/2014 8:17:18 AM
 Plotted By: ddbok

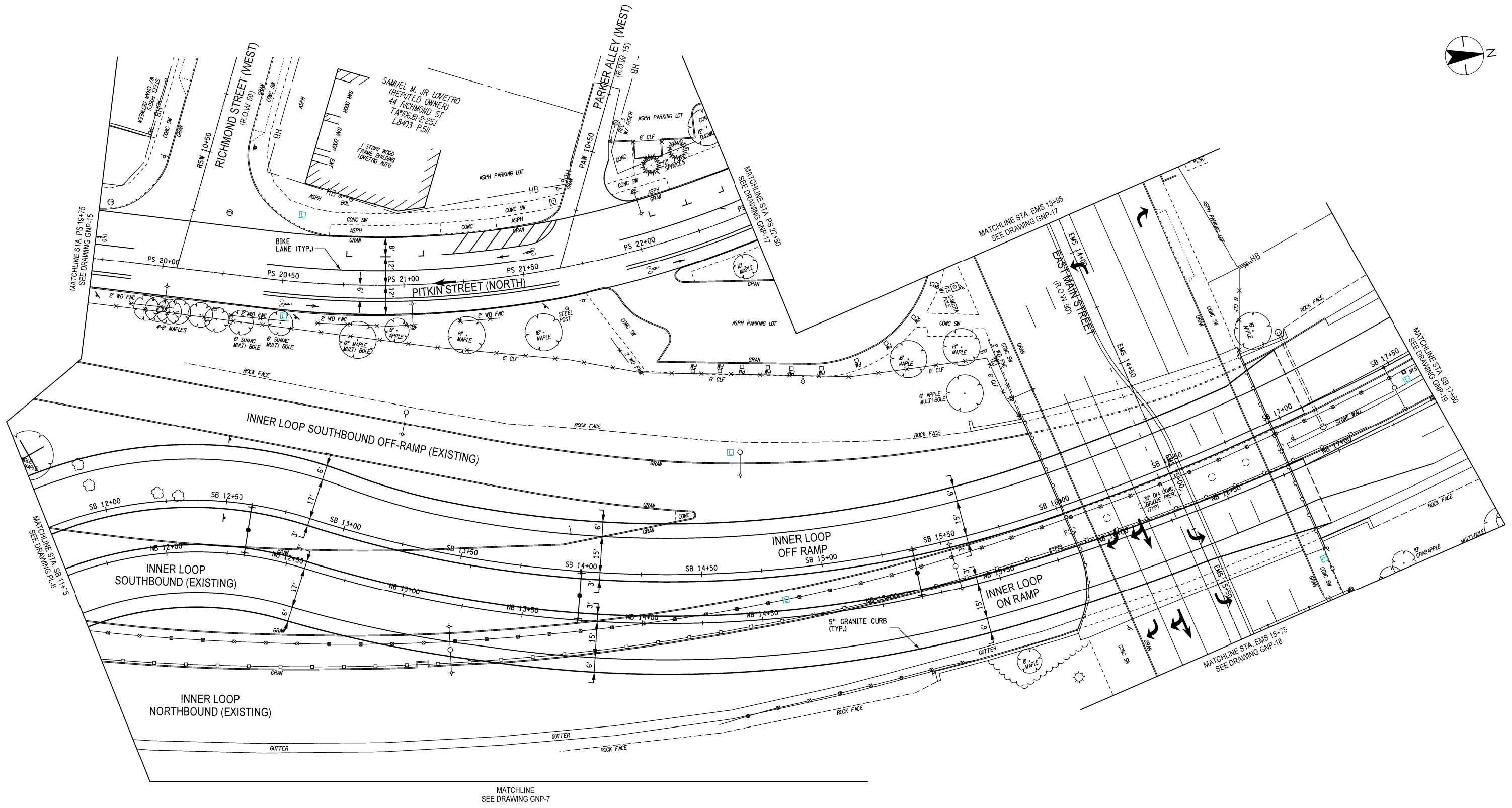
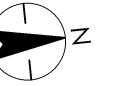

IT IS A VIOLATION OF LAW FOR ANY PERSON, UNLESS THEY ARE ACTING UNDER THE DIRECTION OF A LICENSED PROFESSIONAL ENGINEER, ARCHITECT, LANDSCAPE ARCHITECT, OR LAND SURVEYOR, TO ALTER AN ITEM IN ANY WAY. IF AN ITEM BEARING THE STAMP OF A LICENSED PROFESSIONAL IS ALTERED, THE ALTERING ENGINEER, ARCHITECT, LANDSCAPE ARCHITECT, OR LAND SURVEYOR SHALL STAMP THE DOCUMENT AND INCLUDE THE NOTATION "ALTERED BY" FOLLOWED BY THEIR SIGNATURE, THE DATE OF SUCH ALTERATION, AND A SPECIFIC DESCRIPTION OF THE ALTERATION.

Revision	By	Appd.	YY.MM.DD	Issued	By	Appd.	YY.MM.DD

Permit Seal

Consultants

Stantec

61 Commercial St. Suite 100
Rochester, NY 14614
www.stantec.com

The Contractor shall verify and be responsible for all dimensions. DO NOT scale the drawing - any errors or omissions shall be reported to Stantec without delay.

The Copyrights to all designs and drawings are the property of Stantec. Reproduction or use for any purpose other than that authorized by Stantec is forbidden.

Client/Project
CITY OF ROCHESTER
INNER LOOP EAST TRANSFORMATION PROJECT
S. CLINTON AVENUE TO EAST MAIN STREET
P.I.N. 4940.T7 D017599
ROCHESTER, NEW YORK

File Name: _____
Dwn. Chkd. Dgn. 14.03
YY.MM.DD

Title
GENERAL PLAN

Project No. 192500295 Scale 1" = 20'

Drawing No. GNP-16 Sheet XXX of XXX Revision 0

Design File: U:\192500295\Transportation\Drawings\Plan Set\Plan_Landscape\report\GNP-16.dgn
 Date/Time: 3/10/2014 8:55:35 AM
 Plotted By: kkleffner

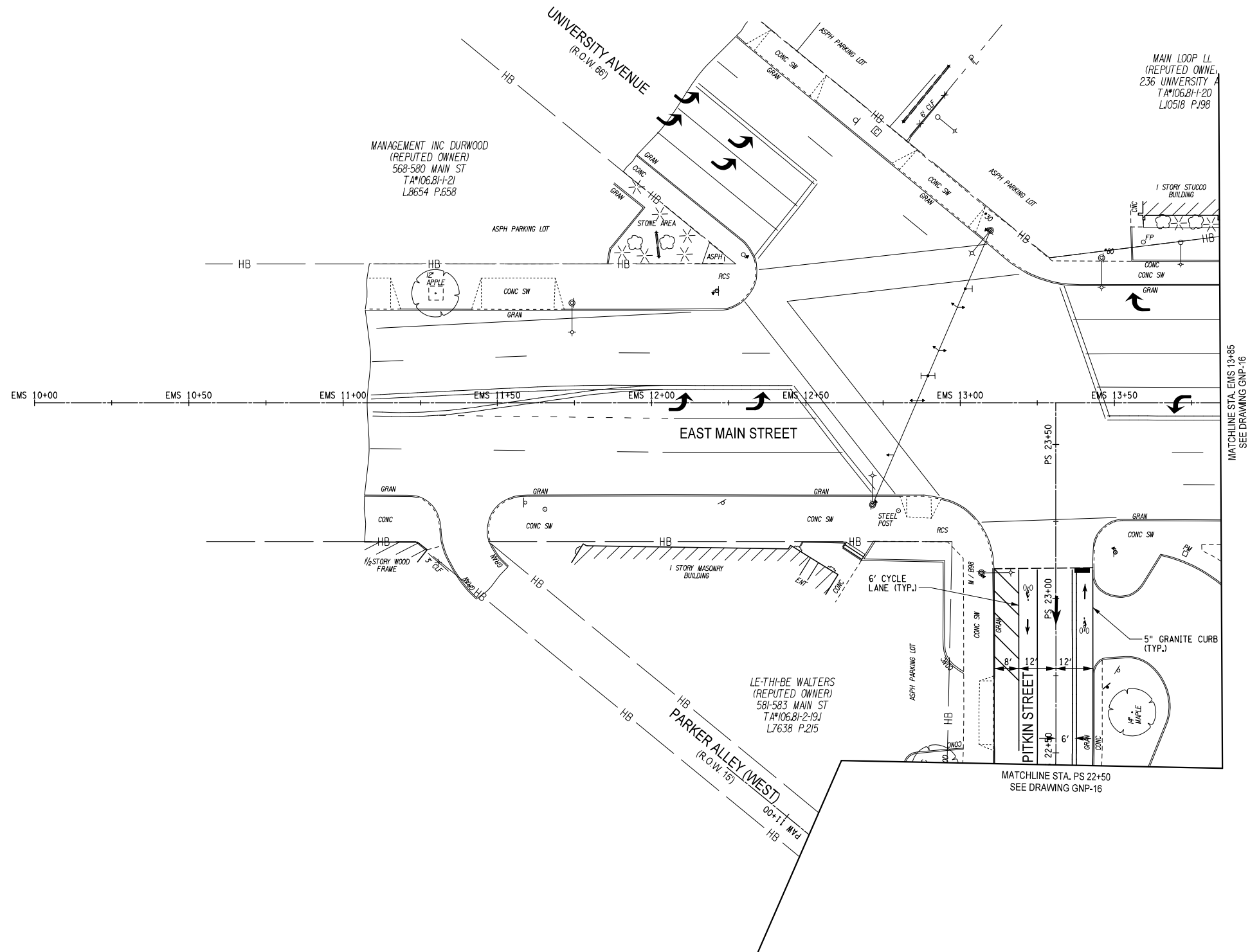

IT IS A VIOLATION OF LAW FOR ANY PERSON, UNLESS THEY ARE ACTING UNDER THE DIRECTION OF A LICENSED PROFESSIONAL ENGINEER, ARCHITECT, LANDSCAPE ARCHITECT, OR LAND SURVEYOR, TO ALTER AN ITEM IN ANY WAY. IF AN ITEM BEARING THE STAMP OF A LICENSED PROFESSIONAL IS ALTERED, THE ALTERING ENGINEER, ARCHITECT, LANDSCAPE ARCHITECT, OR LAND SURVEYOR SHALL STAMP THE DOCUMENT AND INCLUDE THE NOTATION "ALTERED BY" FOLLOWED BY THEIR SIGNATURE, THE DATE OF SUCH ALTERATION, AND A SPECIFIC DESCRIPTION OF THE ALTERATION.

Permit-Seal

Consultants



61 Commercial St, Suite 100
Rochester, NY 14614
www.stantec.com

The Contractor shall verify and be responsible for all dimensions. DO NOT scale the drawing - any errors or omissions shall be reported to Stantec without delay.
The Copyrights to all designs and drawings are the property of Stantec. Reproduction or use for any purpose other than that authorized by Stantec is forbidden.

Client/Project
CITY OF ROCHESTER

INNER LOOP EAST TRANSFORMATION PROJECT
S. CLINTON AVENUE TO EAST MAIN STREET
P.I.N. 4940.T7 D017599

ROCHESTER, NEW YORK

File Name: _____ Dwn. Chkd. Dsgn. 14.03 YY.MM.DD

Title
GENERAL PLAN

Project No. 192500295 Scale 1" = 20'

Drawing No. GNP-17 Sheet XXX of XXX Revision 0

Design File: U:\192500295\Temp\external\Plan Set\PL_design\report\GNP-17.dgn
 Date/Time: 3/27/2014 8:17:20 AM
 Plotted By: gbbok

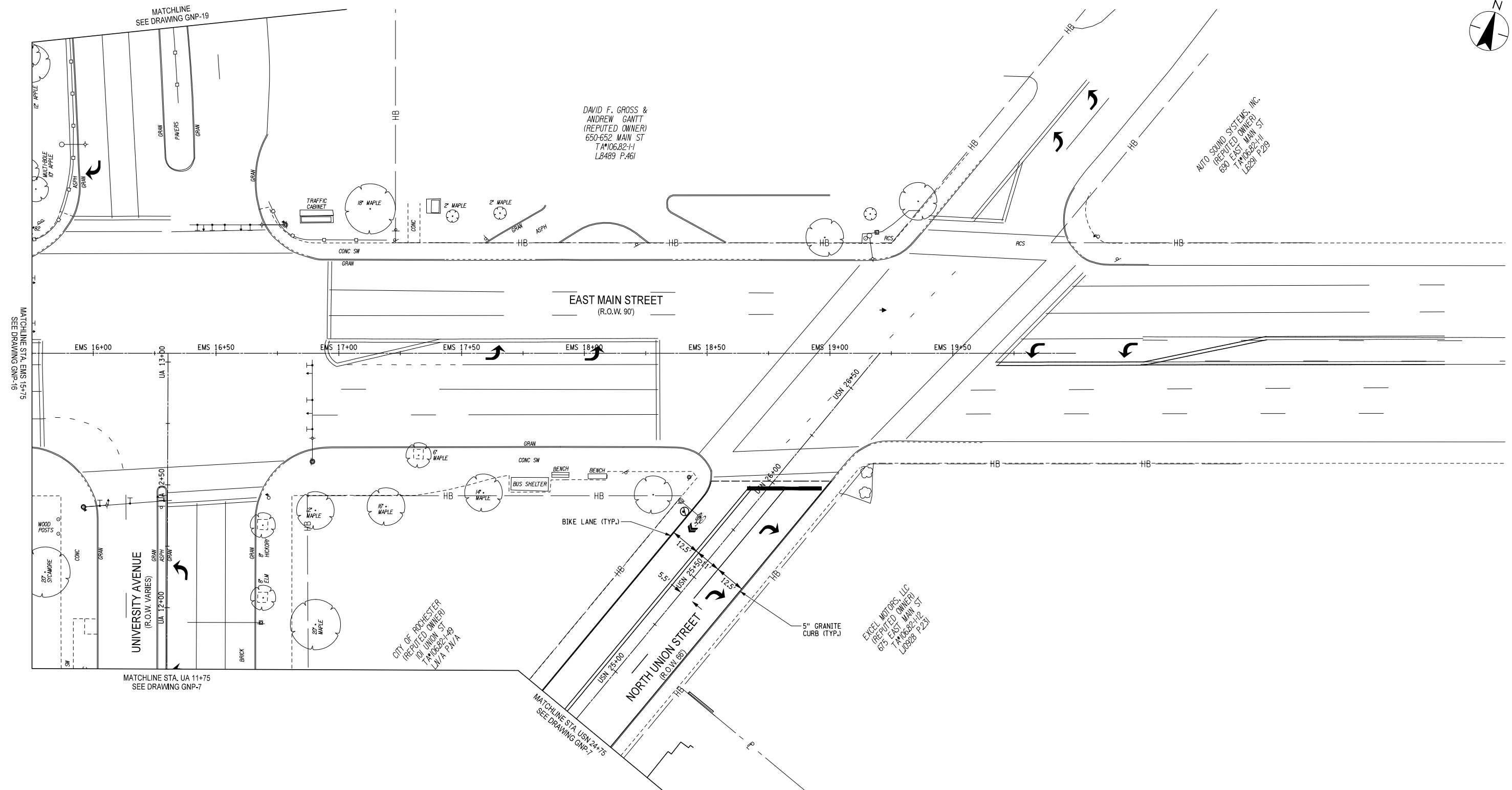

IT IS A VIOLATION OF LAW FOR ANY PERSON, UNLESS THEY ARE ACTING UNDER THE DIRECTION OF A LICENSED PROFESSIONAL ENGINEER, ARCHITECT, LANDSCAPE ARCHITECT, OR LAND SURVEYOR, TO ALTER AN ITEM IN ANY WAY. IF AN ITEM BEARING THE STAMP OF A LICENSED PROFESSIONAL IS ALTERED, THE ALTERING ENGINEER, ARCHITECT, LANDSCAPE ARCHITECT, OR LAND SURVEYOR SHALL STAMP THE DOCUMENT AND INCLUDE THE NOTATION "ALTERED BY" FOLLOWED BY THEIR SIGNATURE, THE DATE OF SUCH ALTERATION, AND A SPECIFIC DESCRIPTION OF THE ALTERATION.

Revision	By	Appd.	YY.MM.DD	Issued	By	Appd.	YY.MM.DD

Permit-Seal	Consultants

61 Commercial St, Suite 100
Rochester, NY 14614
www.stantec.com

The Contractor shall verify and be responsible for all dimensions. DO NOT scale the drawing - any errors or omissions shall be reported to Stantec without delay.

The Copyrights to all designs and drawings are the property of Stantec. Reproduction or use for any purpose other than that authorized by Stantec is forbidden.



Client/Project
CITY OF ROCHESTER
INNER LOOP EAST TRANSFORMATION PROJECT
S. CLINTON AVENUE TO EAST MAIN STREET
P.I.N. 4940.T7 D017599
ROCHESTER, NEW YORK

File Name: _____ Dwn. Chkd. Dsgn. 14.03 YY.MM.DD

Title
GENERAL PLAN

Project No. 192500295 Scale 1' = 20'

Drawing No. GNP-18 Sheet XXX of XXX Revision 0

Design File: U:\192500295\Technical\Drawings\Plan Set\PL_design report\GNP-18.dgn
Date/Time: 3/27/2014 6:17:21 AM
Plotted By: gbbak

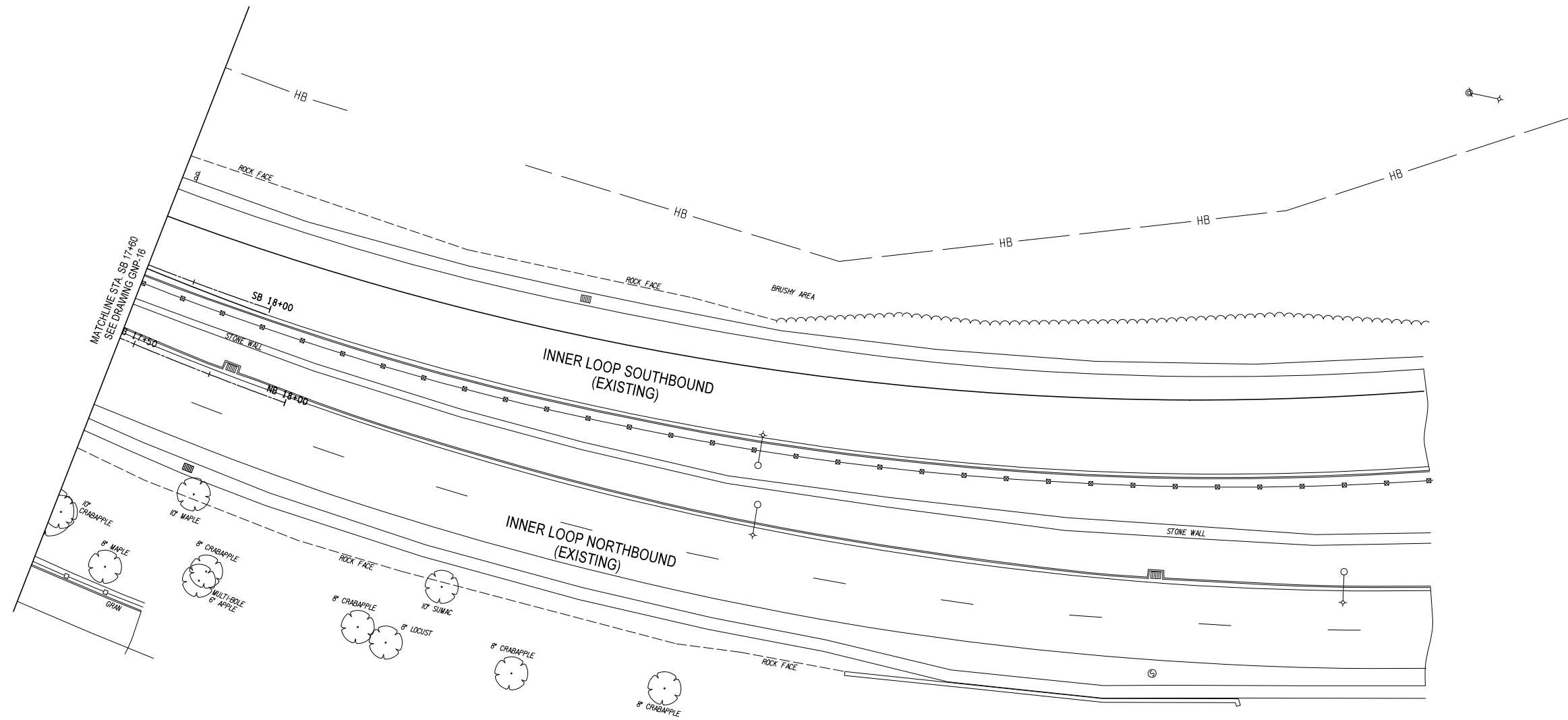

IT IS A VIOLATION OF LAW FOR ANY PERSON, UNLESS THEY ARE ACTING UNDER THE DIRECTION OF A LICENSED PROFESSIONAL ENGINEER, ARCHITECT, LANDSCAPE ARCHITECT, OR LAND SURVEYOR, TO ALTER AN ITEM IN ANY WAY. IF AN ITEM BEARING THE STAMP OF A LICENSED PROFESSIONAL IS ALTERED, THE ALTERING ENGINEER, ARCHITECT, LANDSCAPE ARCHITECT, OR LAND SURVEYOR SHALL STAMP THE DOCUMENT AND INCLUDE THE NOTATION "ALTERED BY" FOLLOWED BY THEIR SIGNATURE, THE DATE OF SUCH ALTERATION, AND A SPECIFIC DESCRIPTION OF THE ALTERATION.

Revision	By	Appd.	YY.MM.DD

Issued	By	Appd.	YY.MM.DD

Permit-Seal

Consultants



61 Commercial St, Suite 100
 Rochester, NY 14614
 www.stantec.com

The Contractor shall verify and be responsible for all dimensions. DO NOT scale the drawing - any errors or omissions shall be reported to Stantec without delay.

The Copyrights to all designs and drawings are the property of Stantec. Reproduction or use for any purpose other than that authorized by Stantec is forbidden.

Client/Project
 CITY OF ROCHESTER
 INNER LOOP EAST TRANSFORMATION PROJECT
 S. CLINTON AVENUE TO EAST MAIN STREET
 P.I.N. 4940.T7 D017599
 ROCHESTER, NEW YORK

File Name: _____
 Dwn. Chkd. Dsgn. 14.03 YY.MM.DD

Title
 GENERAL PLAN
 INNER LOOP

Project No. 192500295 Scale 1' = 20'

Drawing No. GNP-19 Sheet XXX of XXX Revision 0

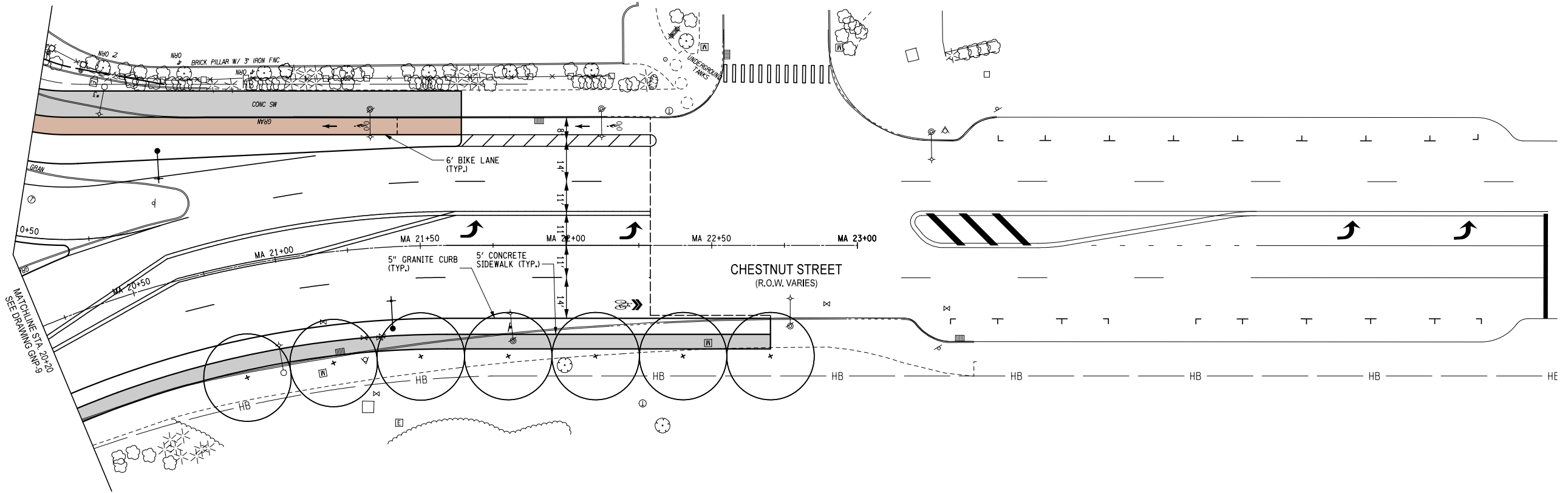
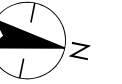

IT IS A VIOLATION OF LAW FOR ANY PERSON, UNLESS THEY ARE ACTING UNDER THE DIRECTION OF A LICENSED PROFESSIONAL ENGINEER, ARCHITECT, LANDSCAPE ARCHITECT, OR LAND SURVEYOR, TO ALTER AN ITEM IN ANY WAY. IF AN ITEM BEARING THE STAMP OF A LICENSED PROFESSIONAL IS ALTERED, THE ALTERING ENGINEER, ARCHITECT, LANDSCAPE ARCHITECT, OR LAND SURVEYOR SHALL STAMP THE DOCUMENT AND INCLUDE THE NOTATION "ALTERED BY" FOLLOWED BY THEIR SIGNATURE, THE DATE OF SUCH ALTERATION, AND A SPECIFIC DESCRIPTION OF THE ALTERATION.

Permit-Seal

Consultants



61 Commercial St, Suite 100
Rochester, NY 14614
www.stantec.com

The Contractor shall verify and be responsible for all dimensions. DO NOT scale the drawing - any errors or omissions shall be reported to Stantec without delay.
The Copyrights to all designs and drawings are the property of Stantec. Reproduction or use for any purpose other than that authorized by Stantec is forbidden.

Client/Project
CITY OF ROCHESTER

INNER LOOP EAST TRANSFORMATION PROJECT
S. CLINTON AVENUE TO EAST MAIN STREET
P.I.N. 4940.T7 D017599

ROCHESTER, NEW YORK

File Name: _____
Dwn. Chkd. Dsgn. 14.03
YY.MM.DD

Title
GENERAL PLAN
CHESTNUT STREET

Project No. 192500295
Scale 1' = 20'

Drawing No. GNP-20
Sheet XXX of XXX
Revision 0

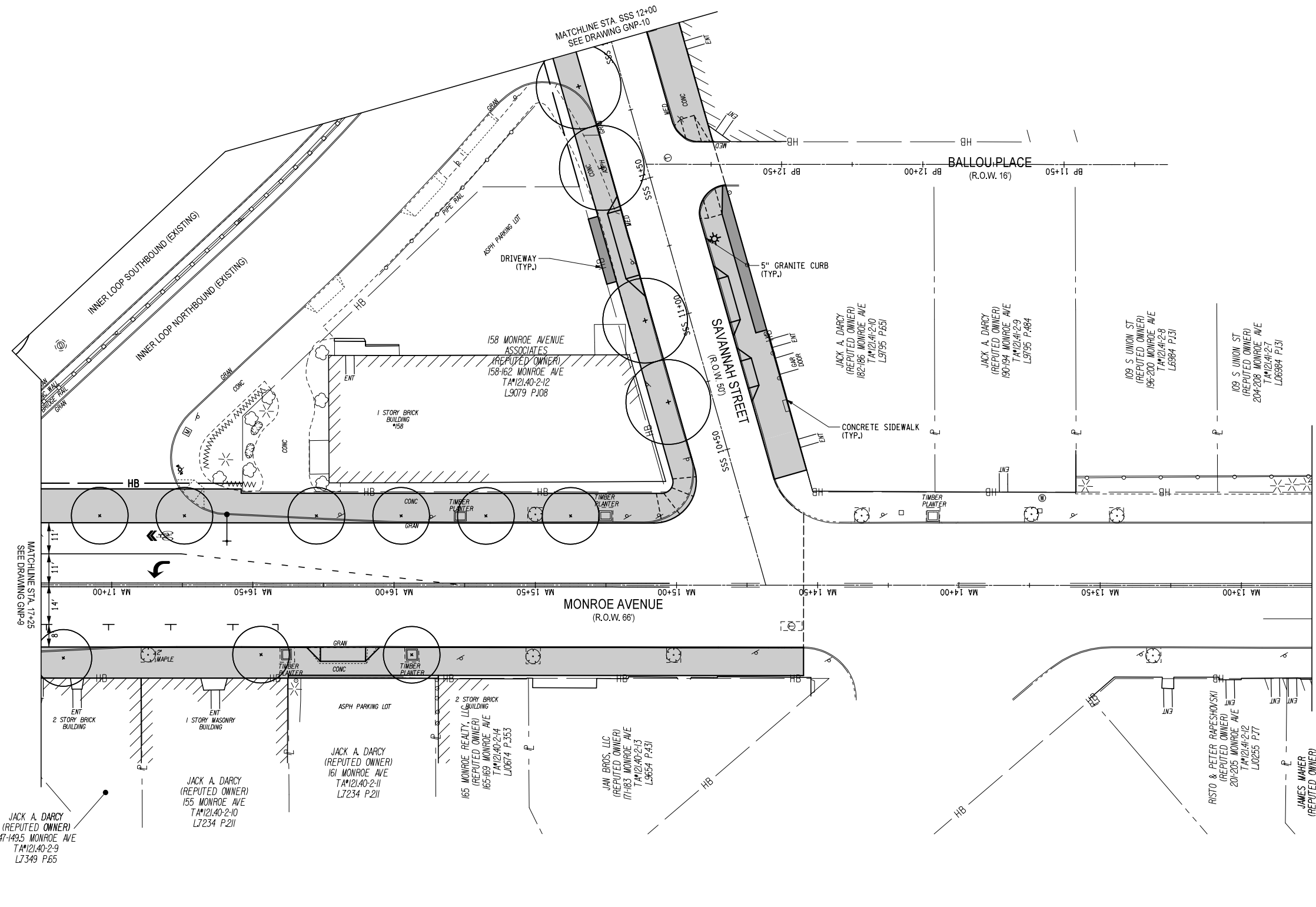

Revision	By	Appd.	YY.MM.DD	Issued	By	Appd.	YY.MM.DD

Permit-Seal

Consultants



61 Commercial St, Suite 100
Rochester, NY 14614
www.stantec.com

The Contractor shall verify and be responsible for all dimensions. DO NOT scale the drawing - any errors or omissions shall be reported to Stantec without delay.
The Copyrights to all designs and drawings are the property of Stantec. Reproduction or use for any purpose other than that authorized by Stantec is forbidden.

Client/Project
CITY OF ROCHESTER
INNER LOOP EAST TRANSFORMATION PROJECT
S. CLINTON AVENUE TO EAST MAIN STREET
P.I.N. 4940.T7 D017599
ROCHESTER, NEW YORK

File Name: _____
Dwn. Chkd. Dsgn. 14.03
YY.MM.DD

Title
GENERAL PLAN

Project No. 192500295
Scale 1" = 20'

Drawing No. GNP-21
Sheet XXX of XXX
Revision 0

Design File: U:\192500295\192500295\192500295\Drawings\Plan Set\PL_Design\report\GNP-21.dgn
 Date Plotted: 3/27/2014 8:17:23 AM
 Plotted By: dtabak

ORIGINAL SHEET - ANSID HOME

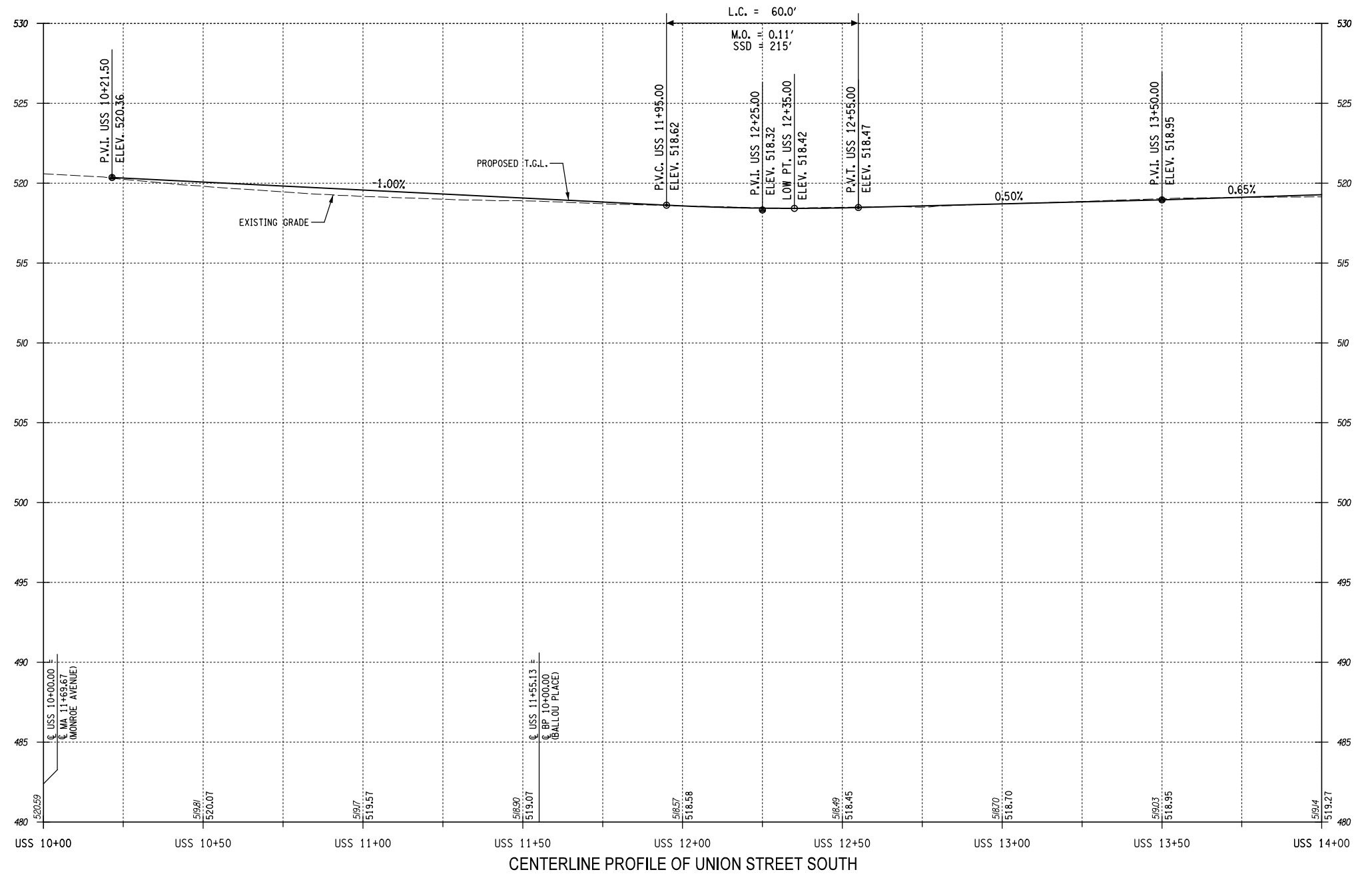

CENTERLINE PROFILE OF UNION STREET SOUTH

IT IS A VIOLATION OF LAW FOR ANY PERSON, UNLESS THEY ARE ACTING UNDER THE DIRECTION OF A LICENSED PROFESSIONAL ENGINEER, ARCHITECT, LANDSCAPE ARCHITECT, OR LAND SURVEYOR, TO ALTER AN ITEM IN ANY WAY. IF AN ITEM BEARING THE STAMP OF A LICENSED PROFESSIONAL IS ALTERED, THE ALTERING ENGINEER, ARCHITECT, LANDSCAPE ARCHITECT, OR LAND SURVEYOR SHALL STAMP THE DOCUMENT AND INCLUDE THE NOTATION "ALTERED BY" FOLLOWED BY THEIR SIGNATURE, THE DATE OF SUCH ALTERATION, AND A SPECIFIC DESCRIPTION OF THE ALTERATION.

Permit-Seal

Consultants



61 Commercial St, Suite 100
Rochester, NY 14614
www.stantec.com

The Contractor shall verify and be responsible for all dimensions. DO NOT scale the drawing - any errors or omissions shall be reported to Stantec without delay.

The Copyrights to all designs and drawings are the property of Stantec. Reproduction or use for any purpose other than that authorized by Stantec is forbidden.

Client/Project

CITY OF ROCHESTER

INNER LOOP EAST TRANSFORMATION PROJECT
S. CLINTON AVENUE TO EAST MAIN STREET
P.I.N. 4940.T7 D017599

ROCHESTER, NEW YORK

File Name:

14.03
YY.MM.DD

Title

GENERAL PROFILE

Project No.
192500295

Scale
H: 1"=40' V: 1"=8'

Drawing No.

Sheet Revision

PR-1

XXX of XXX

0

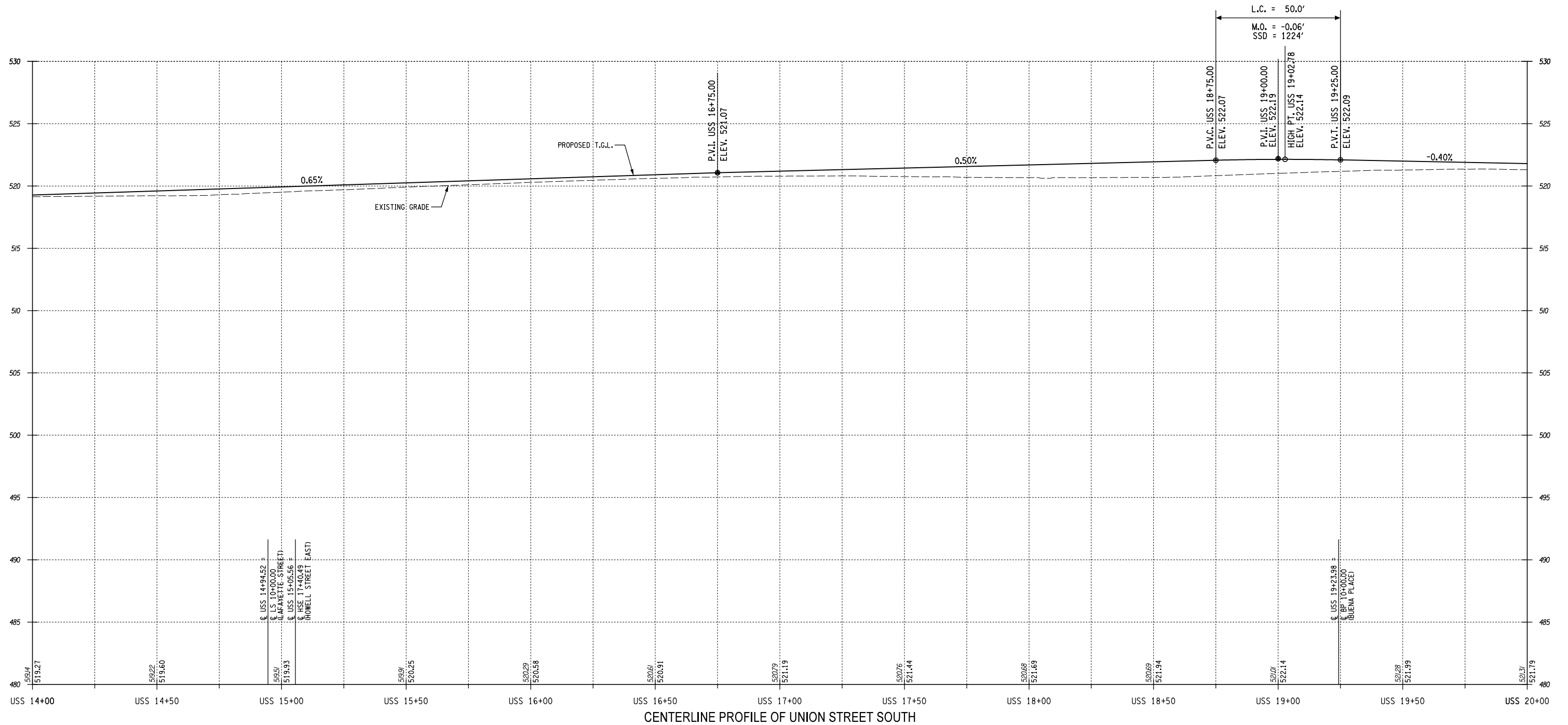

Design File: U:\192500295\Tentative\Drawings\Plan Set\PR\PR-02.dgn
 Date Plotted: 3/6/2014 3:06:45 PM
 Plotted By: sromer

Revision	By	Appd.	YY.MM.DD	Issued	By	Appd.	YY.MM.DD

Permit-Seal

Consultants



Stantec

61 Commercial St, Suite 100
Rochester, NY 14614
www.stantec.com

The Contractor shall verify and be responsible for all dimensions. DO NOT scale the drawing - any errors or omissions shall be reported to Stantec without delay.

The Copyrights to all designs and drawings are the property of Stantec. Reproduction or use for any purpose other than that authorized by Stantec is forbidden.

Client/Project
CITY OF ROCHESTER

INNER LOOP EAST TRANSFORMATION PROJECT
S. CLINTON AVENUE TO EAST MAIN STREET
P.I.N. 4940.T7 D017599

ROCHESTER, NEW YORK

File Name: _____

Dwn. Chkd. Dsgn. 14.03 YY.MM.DD

Title
GENERAL PROFILE

Project No. 192500295 Scale H: 1"=40' V: 1"=8'

Drawing No. PR-2 Sheet XXX of XXX Revision 0

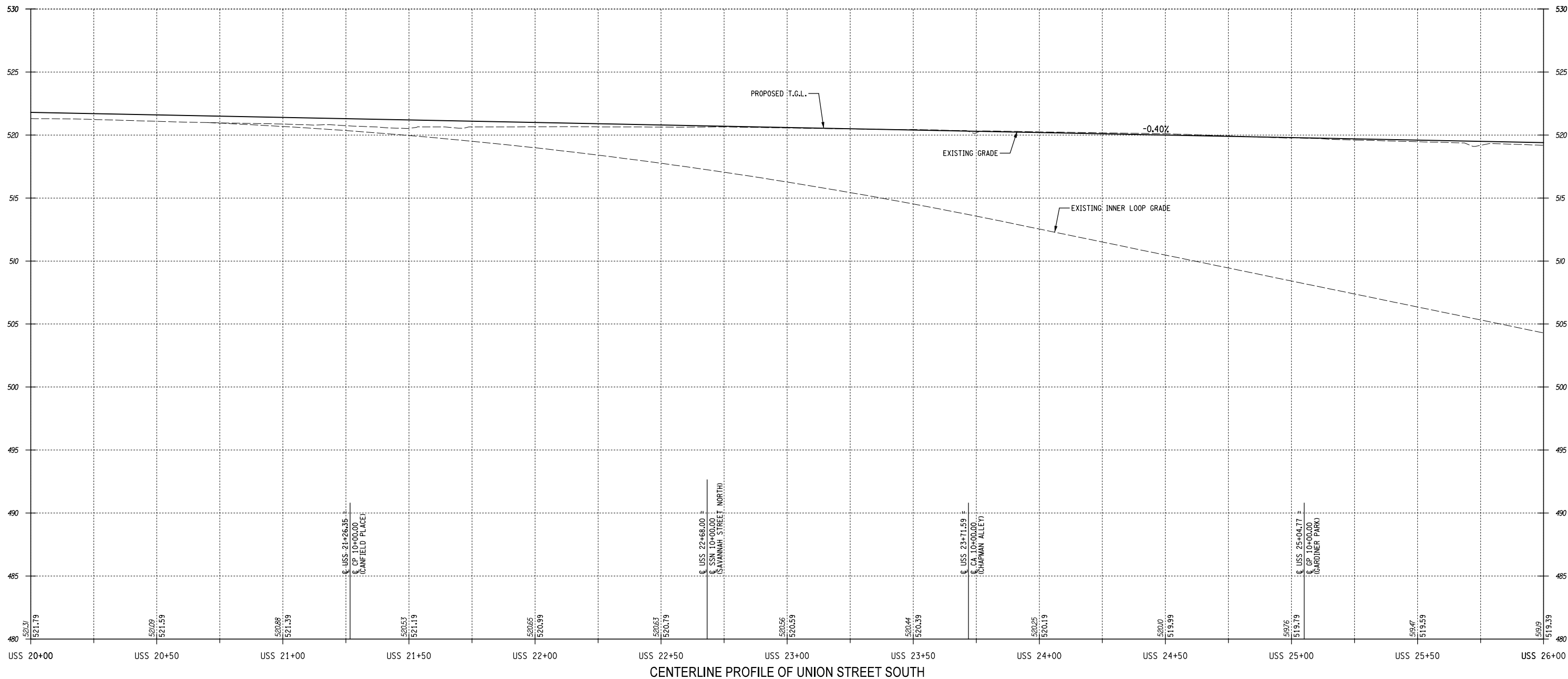

Design File: \\s\192500295\Technical\Drawings\Plan Set\PR-03.dgn
 Date Plotted: 3/27/2014 3:06:46 PM
 Plotted By: sommer

Revision				Issued			
By	Appd.	YY.MM.DD		By	Appd.	YY.MM.DD	

Permit-Seal

Consultants



The Contractor shall verify and be responsible for all dimensions. DO NOT scale the drawing - any errors or omissions shall be reported to Stantec without delay.

The Copyrights to all designs and drawings are the property of Stantec. Reproduction or use for any purpose other than that authorized by Stantec is forbidden.

Client/Project
CITY OF ROCHESTER
 INNER LOOP EAST TRANSFORMATION PROJECT
 S. CLINTON AVENUE TO EAST MAIN STREET
 P.I.N. 4940.T7 D017599
 ROCHESTER, NEW YORK

File Name: _____

Dwn. Chkd. Dsgn. 14.03
 YY.MM.DD

Title
GENERAL PROFILE

Project No. 192500295 Scale H: 1"=40' V: 1"=8'

Drawing No. PR-3 Sheet XXX of XXX Revision 0

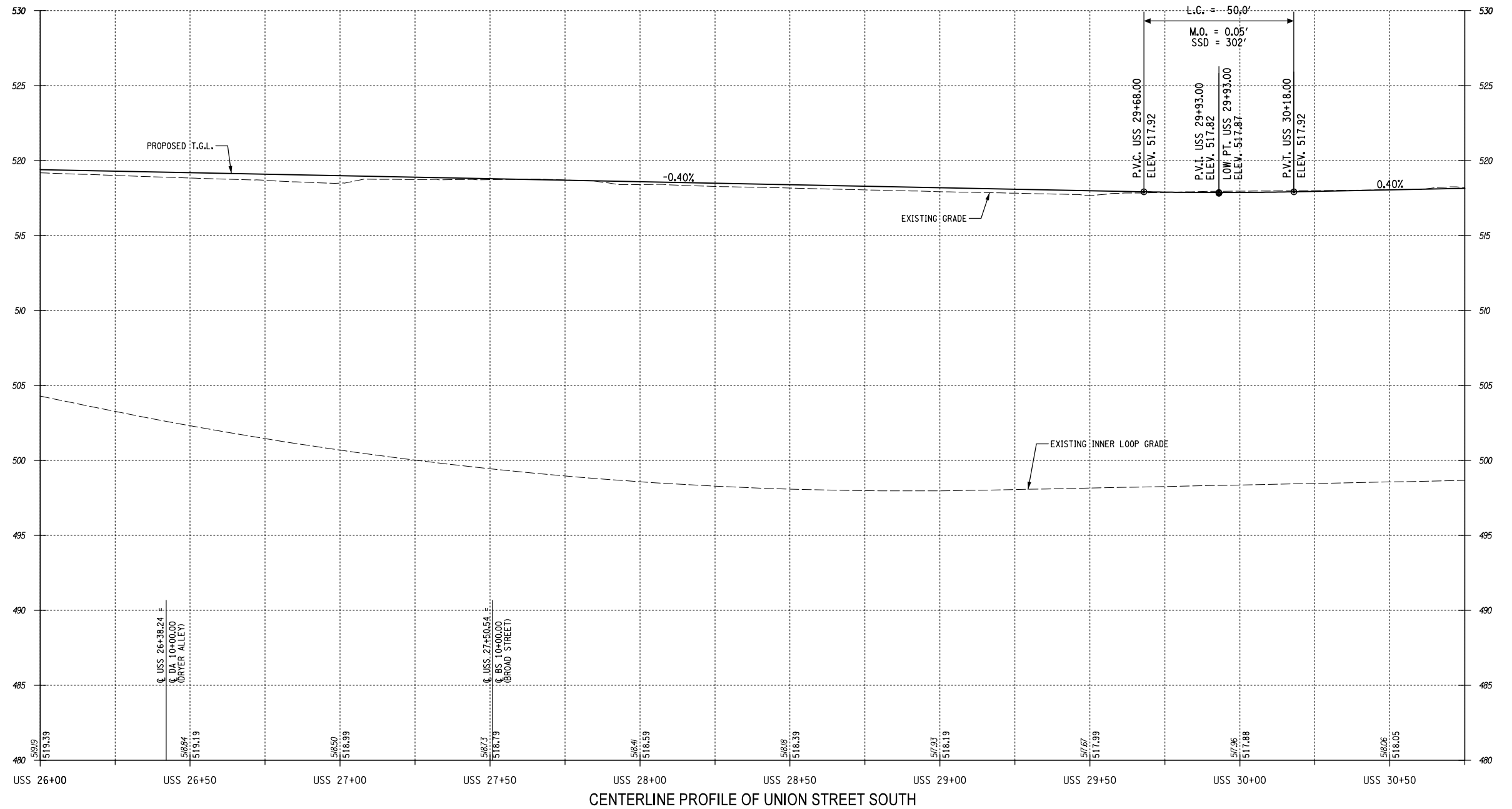

Design File: \\s020295\Projects\192500295\InnerLoopEastTransformation\Drawings\Plan Set\PR-4.dgn
 Date Plotted: 3/27/2014 3:06:47 PM
 Plotted By: somester

IT IS A VIOLATION OF LAW FOR ANY PERSON, UNLESS THEY ARE ACTING UNDER THE DIRECTION OF A LICENSED PROFESSIONAL ENGINEER, ARCHITECT, LANDSCAPE ARCHITECT, OR LAND SURVEYOR, TO ALTER AN ITEM IN ANY WAY. IF AN ITEM BEARING THE STAMP OF A LICENSED PROFESSIONAL IS ALTERED, THE ALTERING ENGINEER, ARCHITECT, LANDSCAPE ARCHITECT, OR LAND SURVEYOR SHALL STAMP THE DOCUMENT AND INCLUDE THE NOTATION "ALTERED BY" FOLLOWED BY THEIR SIGNATURE, THE DATE OF SUCH ALTERATION, AND A SPECIFIC DESCRIPTION OF THE ALTERATION.				Permit-Seal	Consultants	 61 Commercial St., Suite 100 Rochester, NY 14614 www.stantec.com <small>The Contractor shall verify and be responsible for all dimensions. DO NOT scale the drawing - any errors or omissions shall be reported to Stantec without delay. The Copyrights to all designs and drawings are the property of Stantec. Reproduction or use for any purpose other than that authorized by Stantec is forbidden.</small>	Client/Project CITY OF ROCHESTER INNER LOOP EAST TRANSFORMATION PROJECT S. CLINTON AVENUE TO EAST MAIN STREET P.I.N. 4940.T7 D017599 ROCHESTER, NEW YORK	Title GENERAL PROFILE Project No. 192500295 Scale H: 1"=40' V: 1"=8' Drawing No. PR-4 Sheet XXX of XXX Revision 0																																																																																														
<table border="1"> <thead> <tr> <th>Revision</th> <th>By</th> <th>Appd.</th> <th>YY.MM.DD</th> </tr> </thead> <tbody> <tr><td> </td><td> </td><td> </td><td> </td></tr> <tr><td> </td><td> </td><td> </td><td> </td></tr> <tr><td> </td><td> </td><td> </td><td> </td></tr> <tr><td> </td><td> </td><td> </td><td> </td></tr> <tr><td> </td><td> </td><td> </td><td> </td></tr> <tr><td> </td><td> </td><td> </td><td> </td></tr> <tr><td> </td><td> </td><td> </td><td> </td></tr> <tr><td> </td><td> </td><td> </td><td> </td></tr> <tr><td> </td><td> </td><td> </td><td> </td></tr> <tr><td> </td><td> </td><td> </td><td> </td></tr> </tbody> </table>	Revision	By	Appd.	YY.MM.DD																																									<table border="1"> <thead> <tr> <th>Issued</th> <th>By</th> <th>Appd.</th> <th>YY.MM.DD</th> </tr> </thead> <tbody> <tr><td> </td><td> </td><td> </td><td> </td></tr> <tr><td> </td><td> </td><td> </td><td> </td></tr> <tr><td> </td><td> </td><td> </td><td> </td></tr> <tr><td> </td><td> </td><td> </td><td> </td></tr> <tr><td> </td><td> </td><td> </td><td> </td></tr> <tr><td> </td><td> </td><td> </td><td> </td></tr> <tr><td> </td><td> </td><td> </td><td> </td></tr> <tr><td> </td><td> </td><td> </td><td> </td></tr> <tr><td> </td><td> </td><td> </td><td> </td></tr> <tr><td> </td><td> </td><td> </td><td> </td></tr> </tbody> </table>	Issued	By	Appd.	YY.MM.DD																																									<table border="1"> <thead> <tr> <th>File Name:</th> <th>Dwn.</th> <th>Chkd.</th> <th>Dsgn.</th> <th>14.03</th> <th>YY.MM.DD</th> </tr> </thead> <tbody> <tr> <td> </td> <td> </td> <td> </td> <td> </td> <td> </td> <td> </td> </tr> </tbody> </table>	File Name:	Dwn.	Chkd.	Dsgn.	14.03	YY.MM.DD						
Revision	By	Appd.	YY.MM.DD																																																																																																			
Issued	By	Appd.	YY.MM.DD																																																																																																			
File Name:	Dwn.	Chkd.	Dsgn.	14.03	YY.MM.DD																																																																																																	

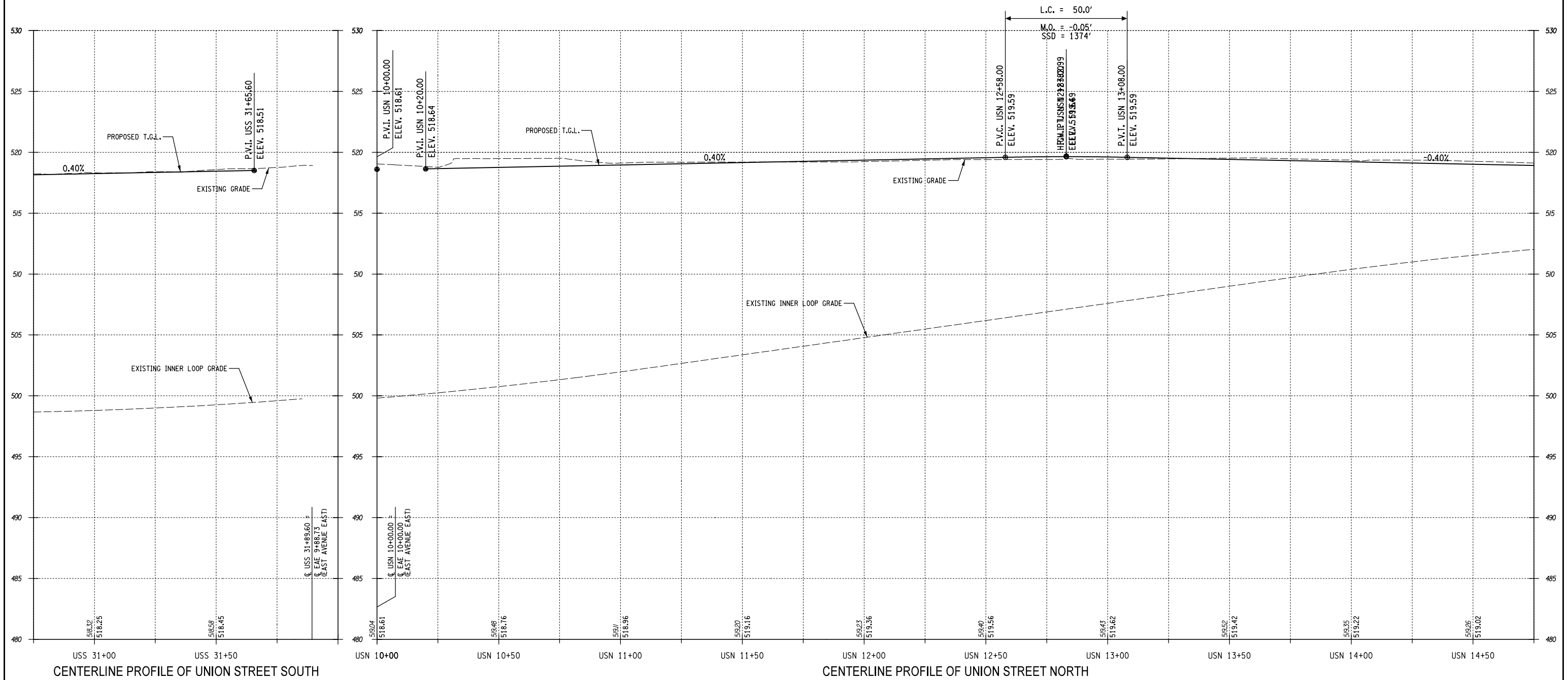

IT IS A VIOLATION OF LAW FOR ANY PERSON, UNLESS THEY ARE ACTING UNDER THE DIRECTION OF A LICENSED PROFESSIONAL ENGINEER, ARCHITECT, LANDSCAPE ARCHITECT, OR LAND SURVEYOR, TO ALTER AN ITEM IN ANY WAY. IF AN ITEM BEARING THE STAMP OF A LICENSED PROFESSIONAL IS ALTERED, THE ALTERING ENGINEER, ARCHITECT, LANDSCAPE ARCHITECT, OR LAND SURVEYOR SHALL STAMP THE DOCUMENT AND INCLUDE THE NOTATION "ALTERED BY" FOLLOWED BY THEIR SIGNATURE, THE DATE OF SUCH ALTERATION, AND A SPECIFIC DESCRIPTION OF THE ALTERATION.

Permit-Seal

Consultants



61 Commercial St, Suite 100
Rochester, NY 14614
www.stantec.com

The Contractor shall verify and be responsible for all dimensions. DO NOT scale the drawing - any errors or omissions shall be reported to Stantec without delay.
The Copyrights to all designs and drawings are the property of Stantec. Reproduction or use for any purpose other than that authorized by Stantec is forbidden.

Client/Project

CITY OF ROCHESTER
INNER LOOP EAST TRANSFORMATION PROJECT
S. CLINTON AVENUE TO EAST MAIN STREET
P.I.N. 4940.T7 D017599
ROCHESTER, NEW YORK

Title

GENERAL PROFILE

Project No.
192500295

Scale
H: 1"=40' V: 1"=8'

Drawing No.

Sheet
Revision

PR-5

XXX of XXX

0

File Name: _____ Dwn. Chkd. Dsgn. 14.03 YY.MM.DD

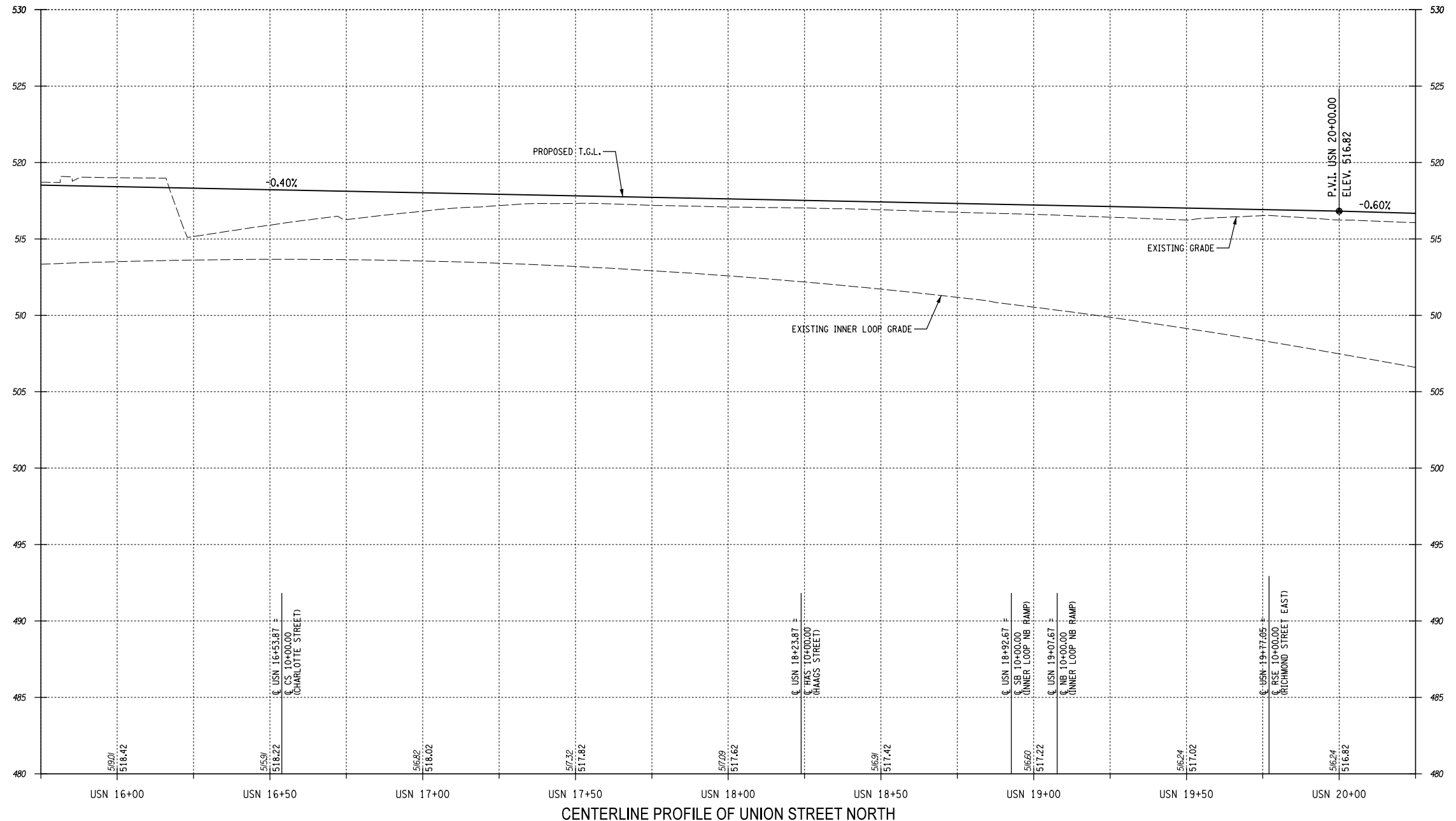

IT IS A VIOLATION OF LAW FOR ANY PERSON, UNLESS THEY ARE ACTING UNDER THE DIRECTION OF A LICENSED PROFESSIONAL ENGINEER, ARCHITECT, LANDSCAPE ARCHITECT, OR LAND SURVEYOR, TO ALTER AN ITEM IN ANY WAY. IF AN ITEM BEARING THE STAMP OF A LICENSED PROFESSIONAL IS ALTERED, THE ALTERING ENGINEER, ARCHITECT, LANDSCAPE ARCHITECT, OR LAND SURVEYOR SHALL STAMP THE DOCUMENT AND INCLUDE THE NOTATION "ALTERED BY" FOLLOWED BY THEIR SIGNATURE, THE DATE OF SUCH ALTERATION, AND A SPECIFIC DESCRIPTION OF THE ALTERATION.

Permit-Seal

Consultants



Client/Project
CITY OF ROCHESTER
INNER LOOP EAST TRANSFORMATION PROJECT
S. CLINTON AVENUE TO EAST MAIN STREET
P.I.N. 4940.T7 D017599
ROCHESTER, NEW YORK

Title
GENERAL PROFILE
Project No. 192500295
Drawing No. PR-6
Scale H: 1"=40' V: 1"=8'
Sheet XXX of XXX
Revision 0

Revision	By	Appd.	YY.MM.DD	Issued	By	Appd.	YY.MM.DD

The Contractor shall verify and be responsible for all dimensions. DO NOT scale the drawing - any errors or omissions shall be reported to Stantec without delay.
The Copyrights to all designs and drawings are the property of Stantec. Reproduction or use for any purpose other than that authorized by Stantec is forbidden.

File Name: _____
Dwn. Chkd. Dsgn. 14.03
YY.MM.DD

Design File: U:\192500295\Transportation\Design\Drawings\Plan Set\PR\PR-06.dgn
 Date Plotted: 3/27/2014 3:06:48 PM
 Plotted By: somelster

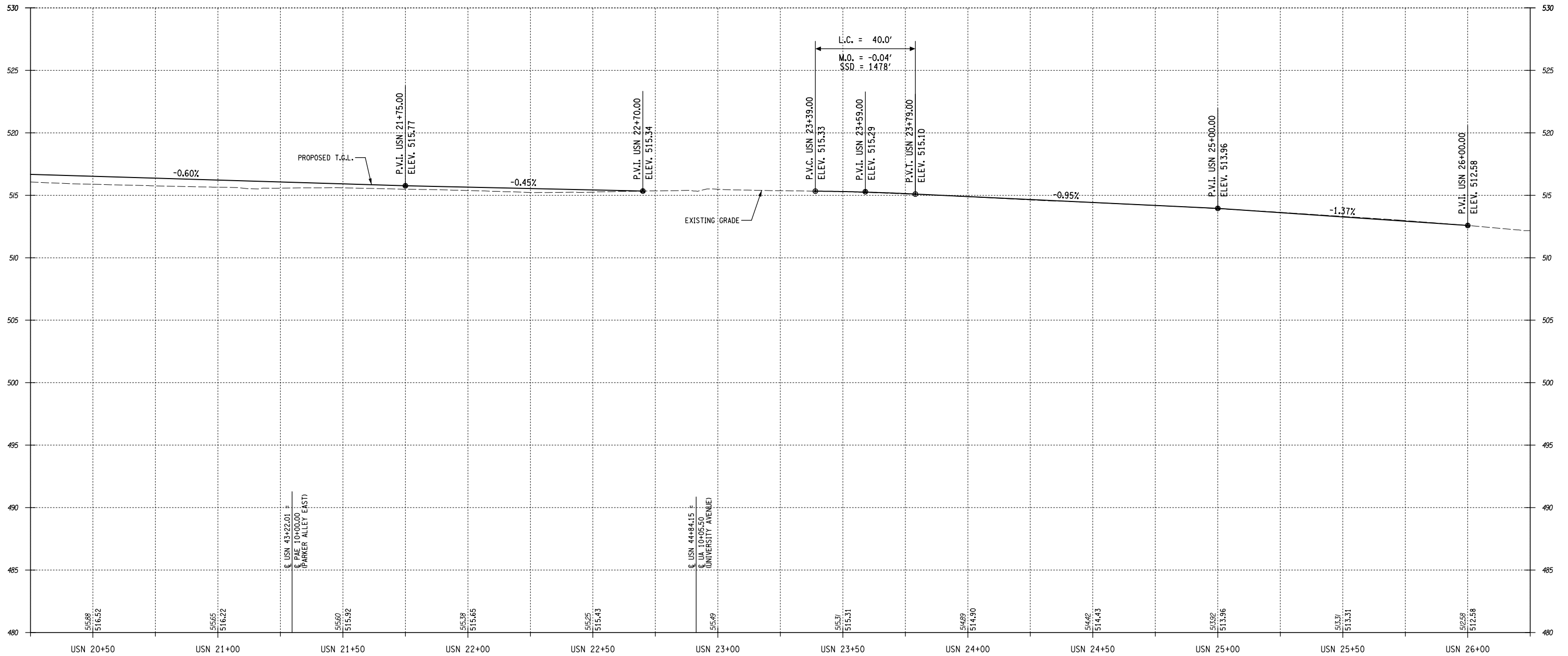

CENTERLINE PROFILE OF UNION STREET NORTH

IT IS A VIOLATION OF LAW FOR ANY PERSON, UNLESS THEY ARE ACTING UNDER THE DIRECTION OF A LICENSED PROFESSIONAL ENGINEER, ARCHITECT, LANDSCAPE ARCHITECT, OR LAND SURVEYOR, TO ALTER AN ITEM IN ANY WAY. IF AN ITEM BEARING THE STAMP OF A LICENSED PROFESSIONAL IS ALTERED, THE ALTERING ENGINEER, ARCHITECT, LANDSCAPE ARCHITECT, OR LAND SURVEYOR SHALL STAMP THE DOCUMENT AND INCLUDE THE NOTATION "ALTERED BY" FOLLOWED BY THEIR SIGNATURE, THE DATE OF SUCH ALTERATION, AND A SPECIFIC DESCRIPTION OF THE ALTERATION.

Permit-Seal	
Consultants	
Revision	By Appd. YY.MM.DD
Issued	By Appd. YY.MM.DD

Stantec
 61 Commercial St. Suite 100
 Rochester, NY 14614
 www.stantec.com

The Contractor shall verify and be responsible for all dimensions. DO NOT scale the drawing - any errors or omissions shall be reported to Stantec without delay.
 The Copyrights to all designs and drawings are the property of Stantec. Reproduction or use for any purpose other than that authorized by Stantec is forbidden.

Client/Project
 CITY OF ROCHESTER
 INNER LOOP EAST TRANSFORMATION PROJECT
 S. CLINTON AVENUE TO EAST MAIN STREET
 P.I.N. 4940.T7 D017599
 ROCHESTER, NEW YORK

File Name: _____ Dwn. Chkd. Dsgn. 14.03 YY.MM.DD

Title
 GENERAL PROFILE

Project No. 192500295
 Drawing No. PR-7

Scale H: 1"=40' V: 1"=8'
 Sheet XXX of XXX
 Revision 0

Design File: U:\192500295\Transportation\Design\Drawings\Plan Set\PR\PR-07.dgn
 Date Plotted: 3/27/2014 3:50:49 PM
 Plotted By: sromelster

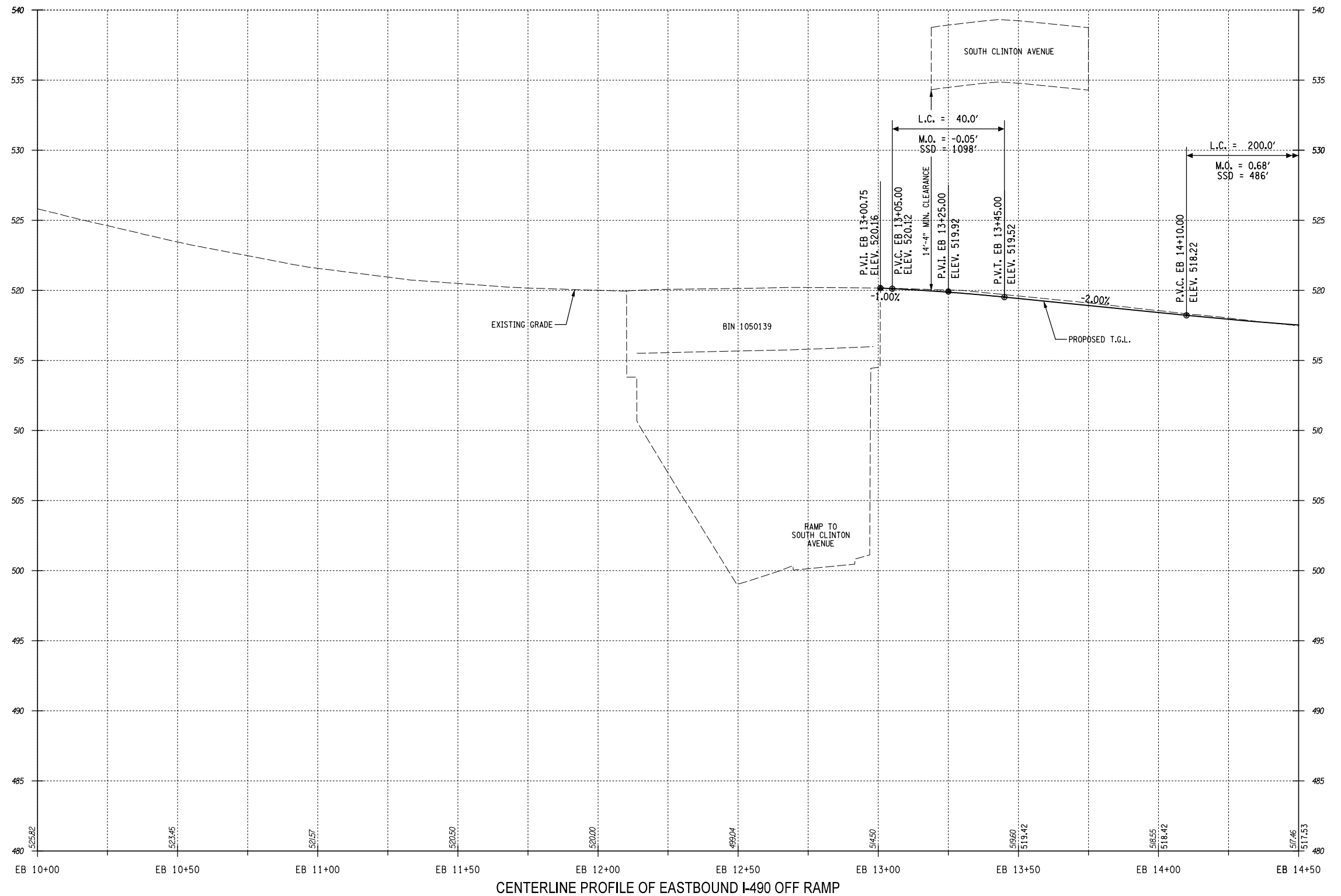

Design File: U:\192500295\Tennis\external\Design\Drawings\Plan Set\PR\PR-08.dgn
 Date Plotted: 3/27/2014 3:06:50 PM
 Plotted By: somerster

IT IS A VIOLATION OF LAW FOR ANY PERSON, UNLESS THEY ARE ACTING UNDER THE DIRECTION OF A LICENSED PROFESSIONAL ENGINEER, ARCHITECT, LANDSCAPE ARCHITECT, OR LAND SURVEYOR, TO ALTER AN ITEM IN ANY WAY. IF AN ITEM BEARING THE STAMP OF A LICENSED PROFESSIONAL IS ALTERED, THE ALTERING ENGINEER, ARCHITECT, LANDSCAPE ARCHITECT, OR LAND SURVEYOR SHALL STAMP THE DOCUMENT AND INCLUDE THE NOTATION "ALTERED BY" FOLLOWED BY THEIR SIGNATURE, THE DATE OF SUCH ALTERATION, AND A SPECIFIC DESCRIPTION OF THE ALTERATION.																																																																																	
Permit-Seal		Consultants																																																																															
<table border="1" style="width: 100%; border-collapse: collapse;"> <thead> <tr> <th>Revision</th> <th>By</th> <th>Appd.</th> <th>YY.MM.DD</th> </tr> </thead> <tbody> <tr><td> </td><td> </td><td> </td><td> </td></tr> <tr><td> </td><td> </td><td> </td><td> </td></tr> <tr><td> </td><td> </td><td> </td><td> </td></tr> <tr><td> </td><td> </td><td> </td><td> </td></tr> <tr><td> </td><td> </td><td> </td><td> </td></tr> <tr><td> </td><td> </td><td> </td><td> </td></tr> <tr><td> </td><td> </td><td> </td><td> </td></tr> <tr><td> </td><td> </td><td> </td><td> </td></tr> <tr><td> </td><td> </td><td> </td><td> </td></tr> </tbody> </table>	Revision	By	Appd.	YY.MM.DD																																					<table border="1" style="width: 100%; border-collapse: collapse;"> <thead> <tr> <th>Issued</th> <th>By</th> <th>Appd.</th> <th>YY.MM.DD</th> </tr> </thead> <tbody> <tr><td> </td><td> </td><td> </td><td> </td></tr> <tr><td> </td><td> </td><td> </td><td> </td></tr> <tr><td> </td><td> </td><td> </td><td> </td></tr> <tr><td> </td><td> </td><td> </td><td> </td></tr> <tr><td> </td><td> </td><td> </td><td> </td></tr> <tr><td> </td><td> </td><td> </td><td> </td></tr> <tr><td> </td><td> </td><td> </td><td> </td></tr> <tr><td> </td><td> </td><td> </td><td> </td></tr> <tr><td> </td><td> </td><td> </td><td> </td></tr> </tbody> </table>	Issued	By	Appd.	YY.MM.DD																																				
Revision	By	Appd.	YY.MM.DD																																																																														
Issued	By	Appd.	YY.MM.DD																																																																														



The Contractor shall verify and be responsible for all dimensions. DO NOT scale the drawing - any errors or omissions shall be reported to Stantec without delay.

The Copyrights to all designs and drawings are the property of Stantec. Reproduction or use for any purpose other than that authorized by Stantec is forbidden.

Client/Project
CITY OF ROCHESTER
 INNER LOOP EAST TRANSFORMATION PROJECT
 S. CLINTON AVENUE TO EAST MAIN STREET
 P.I.N. 4940.T7 D017599
 ROCHESTER, NEW YORK

File Name: _____
 Dwn. Chkd. Dsgn. 14.03 YY.MM.DD

Title
GENERAL PROFILE

Project No. 192500295 Scale H: 1"=40' V: 1"=8'

Drawing No. PR-8 Sheet XXX of XXX Revision 0

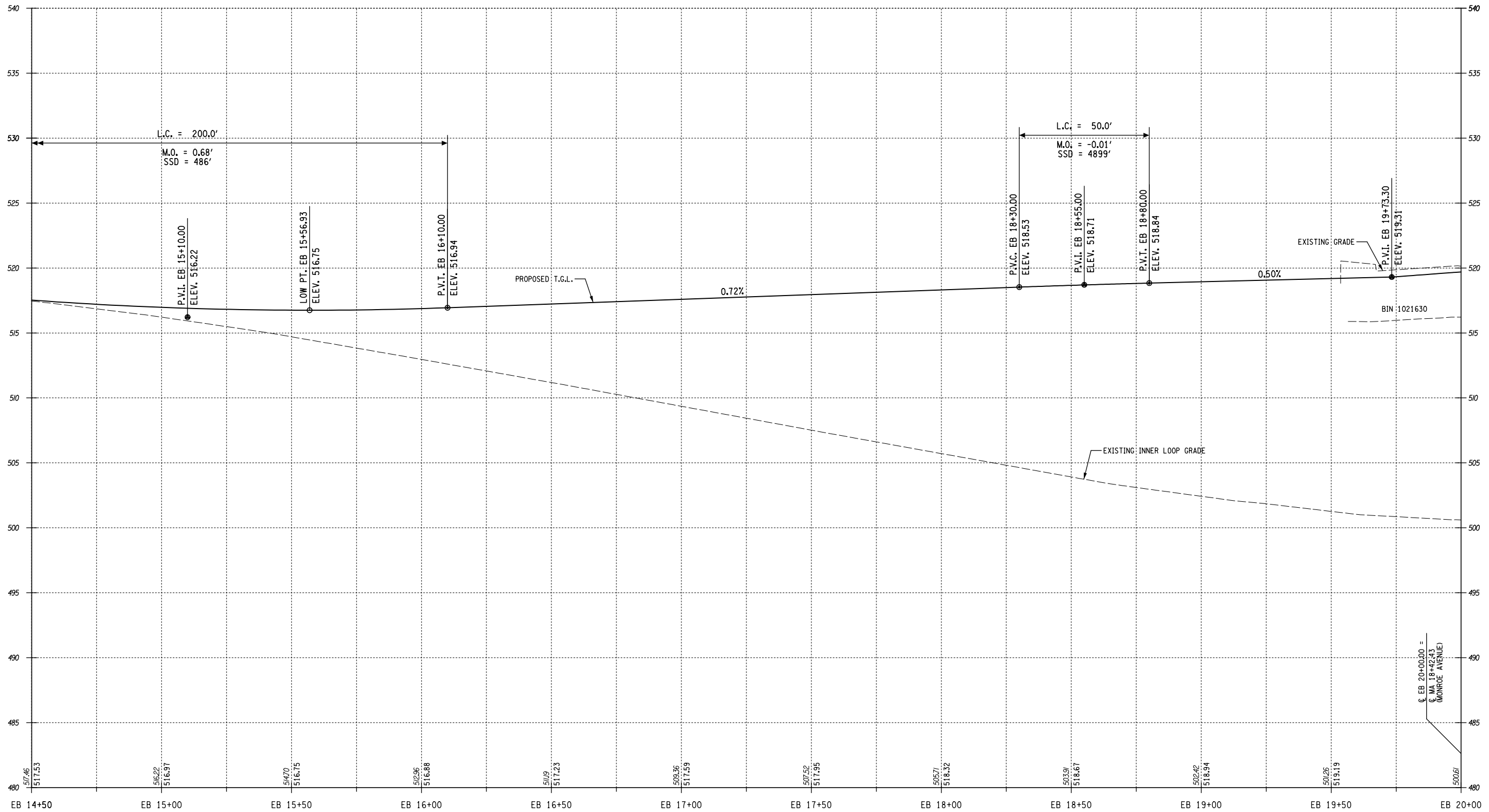

CENTERLINE PROFILE OF EASTBOUND I-490 OFF RAMP

IT IS A VIOLATION OF LAW FOR ANY PERSON, UNLESS THEY ARE ACTING UNDER THE DIRECTION OF A LICENSED PROFESSIONAL ENGINEER, ARCHITECT, LANDSCAPE ARCHITECT, OR LAND SURVEYOR, TO ALTER AN ITEM IN ANY WAY. IF AN ITEM BEARING THE STAMP OF A LICENSED PROFESSIONAL IS ALTERED, THE ALTERING ENGINEER, ARCHITECT, LANDSCAPE ARCHITECT, OR LAND SURVEYOR SHALL STAMP THE DOCUMENT AND INCLUDE THE NOTATION "ALTERED BY" FOLLOWED BY THEIR SIGNATURE, THE DATE OF SUCH ALTERATION, AND A SPECIFIC DESCRIPTION OF THE ALTERATION.

Revision	By	Appd.	YY.MM.DD	Issued	By	Appd.	YY.MM.DD

Permit-Seal

Consultants



The Contractor shall verify and be responsible for all dimensions. DO NOT scale the drawing - any errors or omissions shall be reported to Stantec without delay.
The Copyrights to all designs and drawings are the property of Stantec. Reproduction or use for any purpose other than that authorized by Stantec is forbidden.

Client/Project
CITY OF ROCHESTER
INNER LOOP EAST TRANSFORMATION PROJECT
S. CLINTON AVENUE TO EAST MAIN STREET
P.I.N. 4940.T7 D017599
ROCHESTER, NEW YORK

File Name: _____
Dwn. Chkd. Dsgn. 14.03
YY.MM.DD

Title
GENERAL PROFILE

Project No. 192500295 Scale H: 1"=40' V: 1"=8'

Drawing No. PR-9 Sheet XXX of XXX Revision 0

Design File: U:\192500295\Technical\Drawings\Plan Set\PR-09.dgn
 Date Plotted: 3/27/2014 3:06:50 PM
 Plotted By: sommer

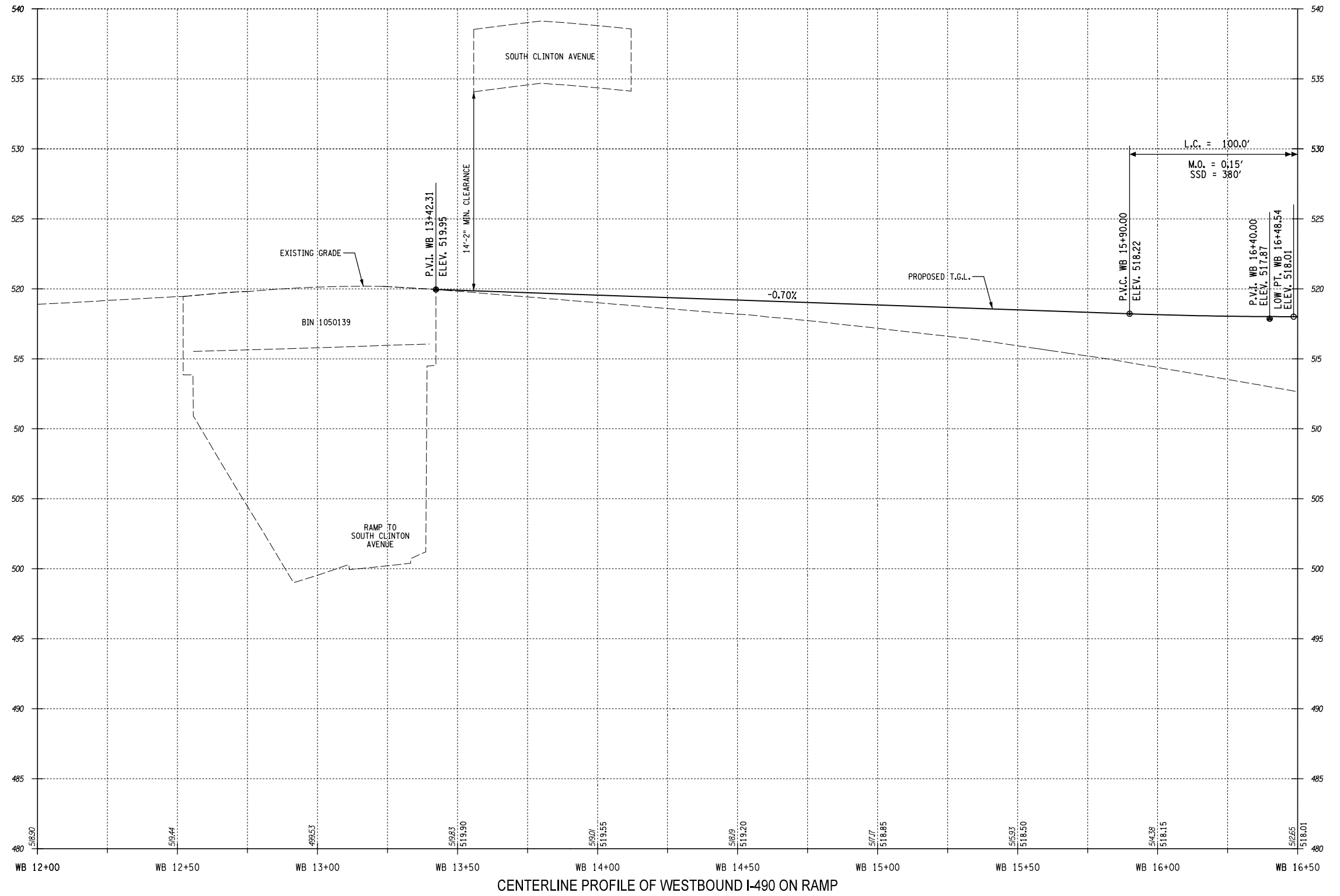

CENTERLINE PROFILE OF WESTBOUND I-490 ON RAMP

IT IS A VIOLATION OF LAW FOR ANY PERSON, UNLESS THEY ARE ACTING UNDER THE DIRECTION OF A LICENSED PROFESSIONAL ENGINEER, ARCHITECT, LANDSCAPE ARCHITECT, OR LAND SURVEYOR, TO ALTER AN ITEM IN ANY WAY. IF AN ITEM BEARING THE STAMP OF A LICENSED PROFESSIONAL IS ALTERED, THE ALTERING ENGINEER, ARCHITECT, LANDSCAPE ARCHITECT, OR LAND SURVEYOR SHALL STAMP THE DOCUMENT AND INCLUDE THE NOTATION "ALTERED BY" FOLLOWED BY THEIR SIGNATURE, THE DATE OF SUCH ALTERATION, AND A SPECIFIC DESCRIPTION OF THE ALTERATION.

Revision	By	Appd.	YY.MM.DD	Issued	By	Appd.	YY.MM.DD

Permit-Seal

Consultants

Stantec
 61 Commercial St., Suite 100
 Rochester, NY 14614
 www.stantec.com

The Contractor shall verify and be responsible for all dimensions. DO NOT scale the drawing - any errors or omissions shall be reported to Stantec without delay.

The Copyrights to all designs and drawings are the property of Stantec. Reproduction or use for any purpose other than that authorized by Stantec is forbidden.

Client/Project
 CITY OF ROCHESTER
 INNER LOOP EAST TRANSFORMATION PROJECT
 S. CLINTON AVENUE TO EAST MAIN STREET
 P.I.N. 4940.T7 D017599
 ROCHESTER, NEW YORK

File Name: _____
 Dwn. Chkd. Dsgn. 14.03
 YY.MM.DD

Title
 GENERAL PROFILE

Project No. 192500295
 Scale H: 1"=40' V: 1"=8'

Drawing No. PR-10
 Sheet XXX of XXX
 Revision 0

Design File: U:\192500295\Transportation\Design\Drawings\Plan Set\PR-10.dgn
 Date Plotted: 3/27/2014 3:06:51 PM
 Plotted By: sommer

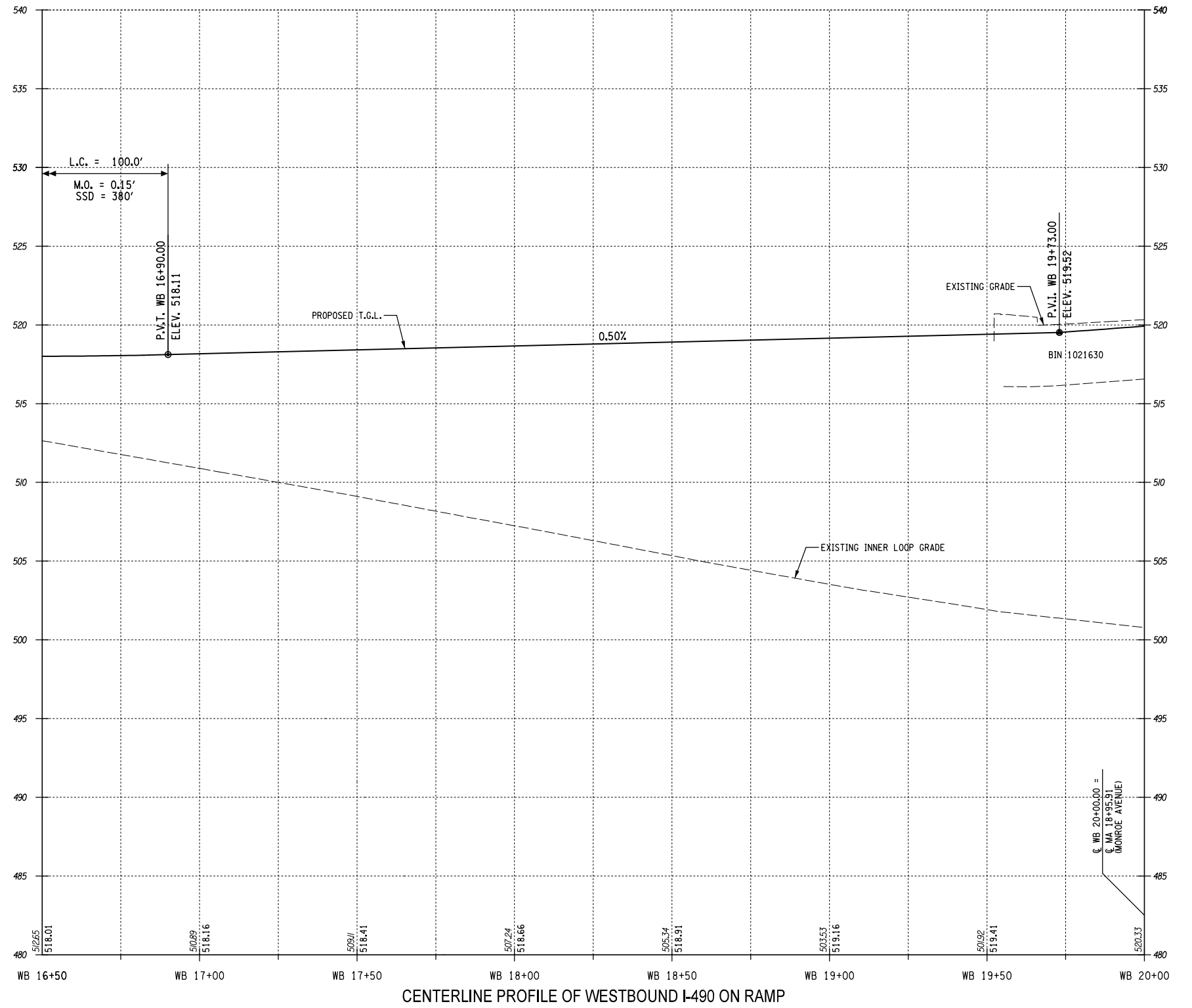

CENTERLINE PROFILE OF WESTBOUND I-490 ON RAMP

IT IS A VIOLATION OF LAW FOR ANY PERSON, UNLESS THEY ARE ACTING UNDER THE DIRECTION OF A LICENSED PROFESSIONAL ENGINEER, ARCHITECT, LANDSCAPE ARCHITECT, OR LAND SURVEYOR, TO ALTER AN ITEM IN ANY WAY. IF AN ITEM BEARING THE STAMP OF A LICENSED PROFESSIONAL IS ALTERED, THE ALTERING ENGINEER, ARCHITECT, LANDSCAPE ARCHITECT, OR LAND SURVEYOR SHALL STAMP THE DOCUMENT AND INCLUDE THE NOTATION "ALTERED BY" FOLLOWED BY THEIR SIGNATURE, THE DATE OF SUCH ALTERATION, AND A SPECIFIC DESCRIPTION OF THE ALTERATION.

Revision	By	Appd.	YY.MM.DD	Issued	By	Appd.	YY.MM.DD

Permit-Seal

Consultants

Stantec

61 Commercial St, Suite 100
Rochester, NY 14614
www.stantec.com

The Contractor shall verify and be responsible for all dimensions. DO NOT scale the drawing - any errors or omissions shall be reported to Stantec without delay.

The Copyrights to all designs and drawings are the property of Stantec. Reproduction or use for any purpose other than that authorized by Stantec is forbidden.

Client/Project
CITY OF ROCHESTER

INNER LOOP EAST TRANSFORMATION PROJECT
S. CLINTON AVENUE TO EAST MAIN STREET
P.I.N. 4940.T7 D017599

ROCHESTER, NEW YORK

File Name: _____

Dwn. Chkd. Dsgn. 14.03
YY.MM.DD

Title
GENERAL PROFILE

Project No. 192500295 Scale H: 1"=40' V: 1"=8'

Drawing No. PR-11 Sheet XXX of XXX Revision 0

Design File: U:\192500295\Tentative\Station\Design\Drawing\Plan Set\PR-11.dgn
 Date Plotted: 3/27/2014 3:06:52 PM
 Plotted By: somester

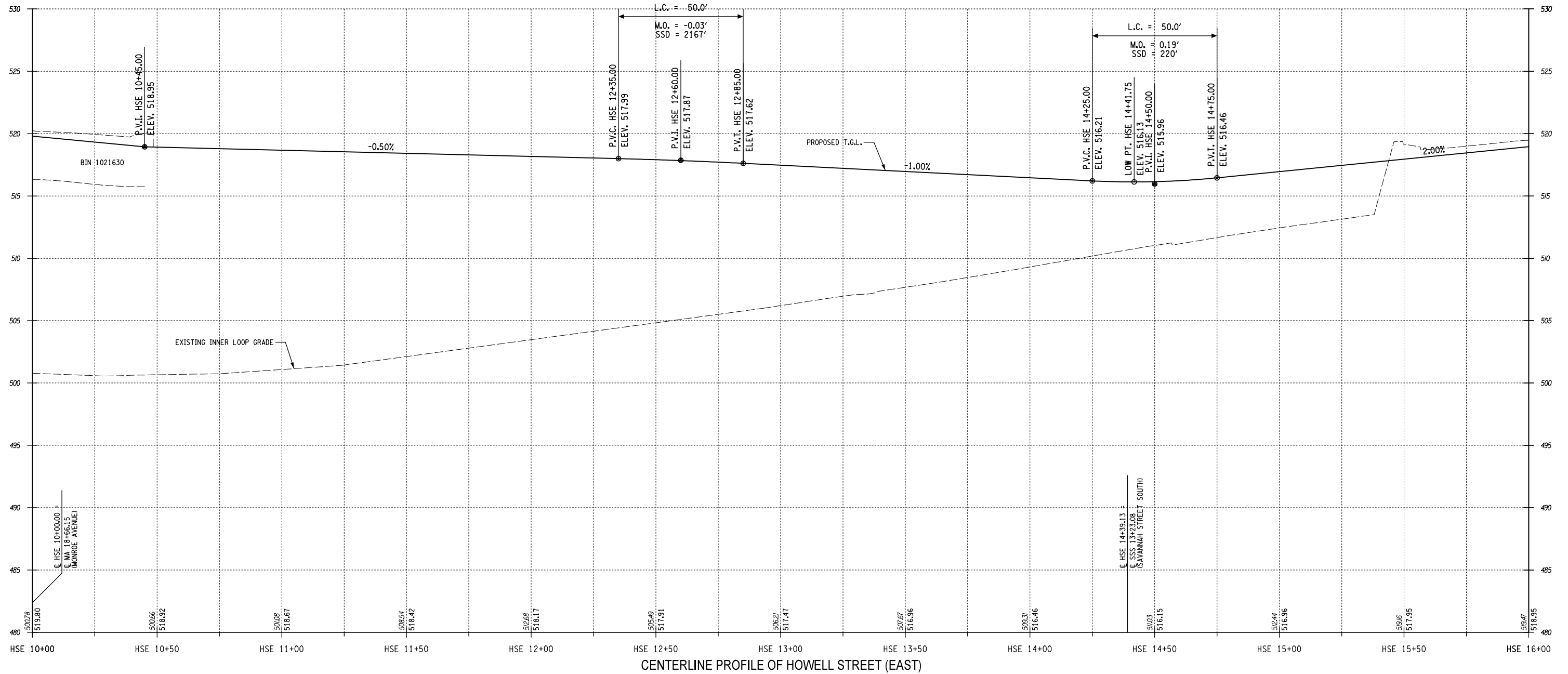

Design File: \\192500295\Technical\Design\Drawings\Plan Set\PR-12.dgn
 Date Plotted: 3/27/2014 3:06:52 PM
 Plotted By: somester

Revision	By	Appd.	YY.MM.DD	Issued	By	Appd.	YY.MM.DD

Permit-Seal	Consultants



Stantec

61 Commercial St, Suite 100
Rochester, NY 14614
www.stantec.com

The Contractor shall verify and be responsible for all dimensions. DO NOT scale the drawing - any errors or omissions shall be reported to Stantec without delay.

The Copyrights to all designs and drawings are the property of Stantec. Reproduction or use for any purpose other than that authorized by Stantec is forbidden.

Client/Project
CITY OF ROCHESTER

INNER LOOP EAST TRANSFORMATION PROJECT
S. CLINTON AVENUE TO EAST MAIN STREET
P.I.N. 4940.T7 D017599

ROCHESTER, NEW YORK

File Name: _____

14.03
YY.MM.DD

Title
GENERAL PROFILE

Project No. 192500295 Scale H: 1"=40' V: 1"=8'

Drawing No. PR-12 Sheet XXX of XXX Revision 0

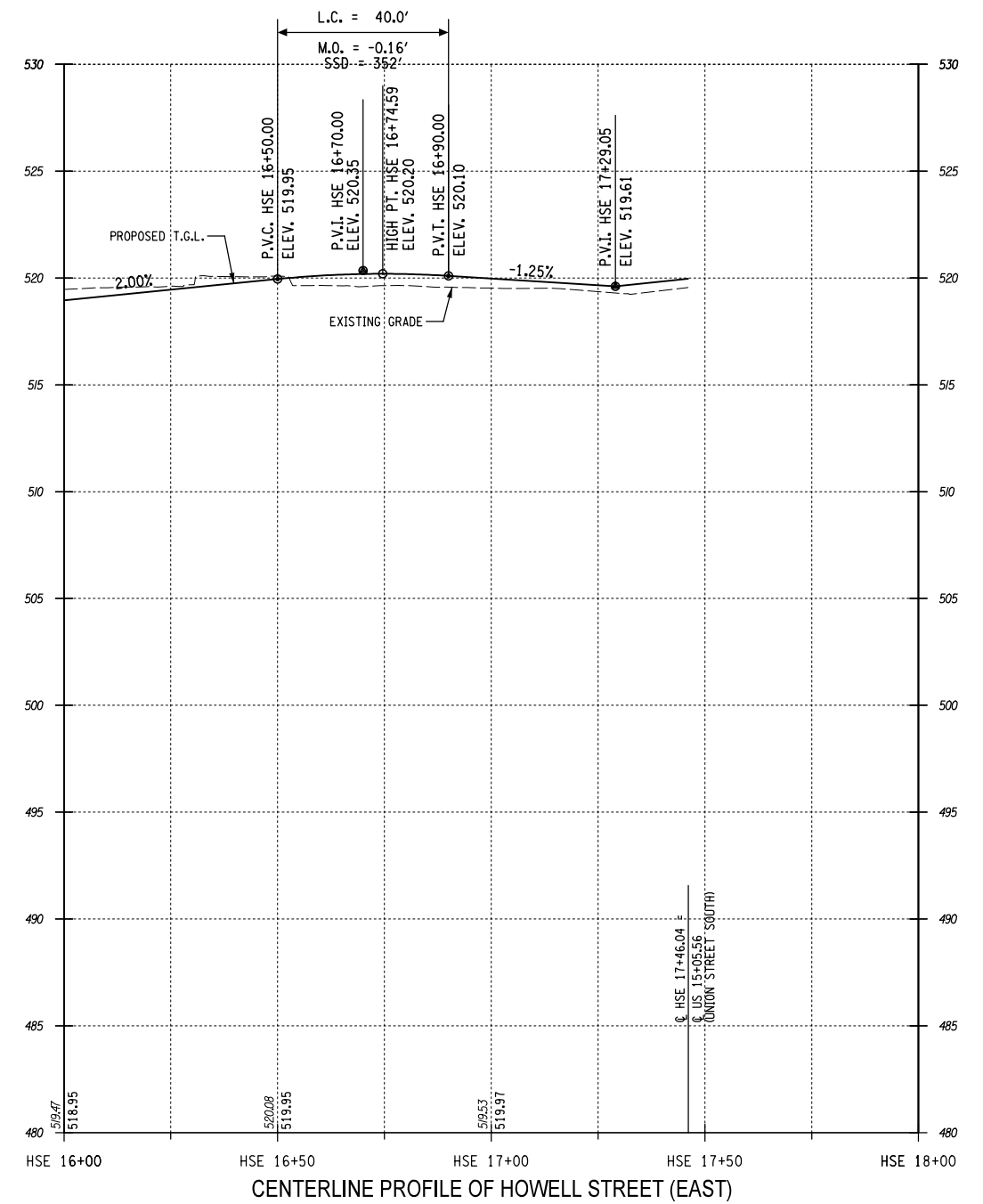

CENTERLINE PROFILE OF HOWELL STREET (EAST)

Design File: U:\192500295\Technical\Drawings\Plan Set\PR-13.dgn
 Date Plotted: 3/27/2014 3:06:55 PM
 Plotted By: sromer

IT IS A VIOLATION OF LAW FOR ANY PERSON, UNLESS THEY ARE ACTING UNDER THE DIRECTION OF A LICENSED PROFESSIONAL ENGINEER, ARCHITECT, LANDSCAPE ARCHITECT, OR LAND SURVEYOR, TO ALTER AN ITEM IN ANY WAY. IF AN ITEM BEARING THE STAMP OF A LICENSED PROFESSIONAL IS ALTERED, THE ALTERING ENGINEER, ARCHITECT, LANDSCAPE ARCHITECT, OR LAND SURVEYOR SHALL STAMP THE DOCUMENT AND INCLUDE THE NOTATION "ALTERED BY" FOLLOWED BY THEIR SIGNATURE, THE DATE OF SUCH ALTERATION, AND A SPECIFIC DESCRIPTION OF THE ALTERATION.

Revision	By	Appd.	YY.MM.DD	Issued	By	Appd.	YY.MM.DD

Permit-Seal

Consultants

Consultants



61 Commercial St, Suite 100
 Rochester, NY 14614
 www.stantec.com

The Contractor shall verify and be responsible for all dimensions. DO NOT scale the drawing - any errors or omissions shall be reported to Stantec without delay.

The Copyrights to all designs and drawings are the property of Stantec. Reproduction or use for any purpose other than that authorized by Stantec is forbidden.

Client/Project
CITY OF ROCHESTER
 INNER LOOP EAST TRANSFORMATION PROJECT
 S. CLINTON AVENUE TO EAST MAIN STREET
 P.I.N. 4940.T7 D017599
 ROCHESTER, NEW YORK

Title
GENERAL PROFILE

Project No.	Scale	
192500295	H: 1"=40' V: 1"=8'	
Drawing No.	Sheet	Revision
PR-13	XXX of XXX	0

ORIGINAL SHEET - ANISO HOME

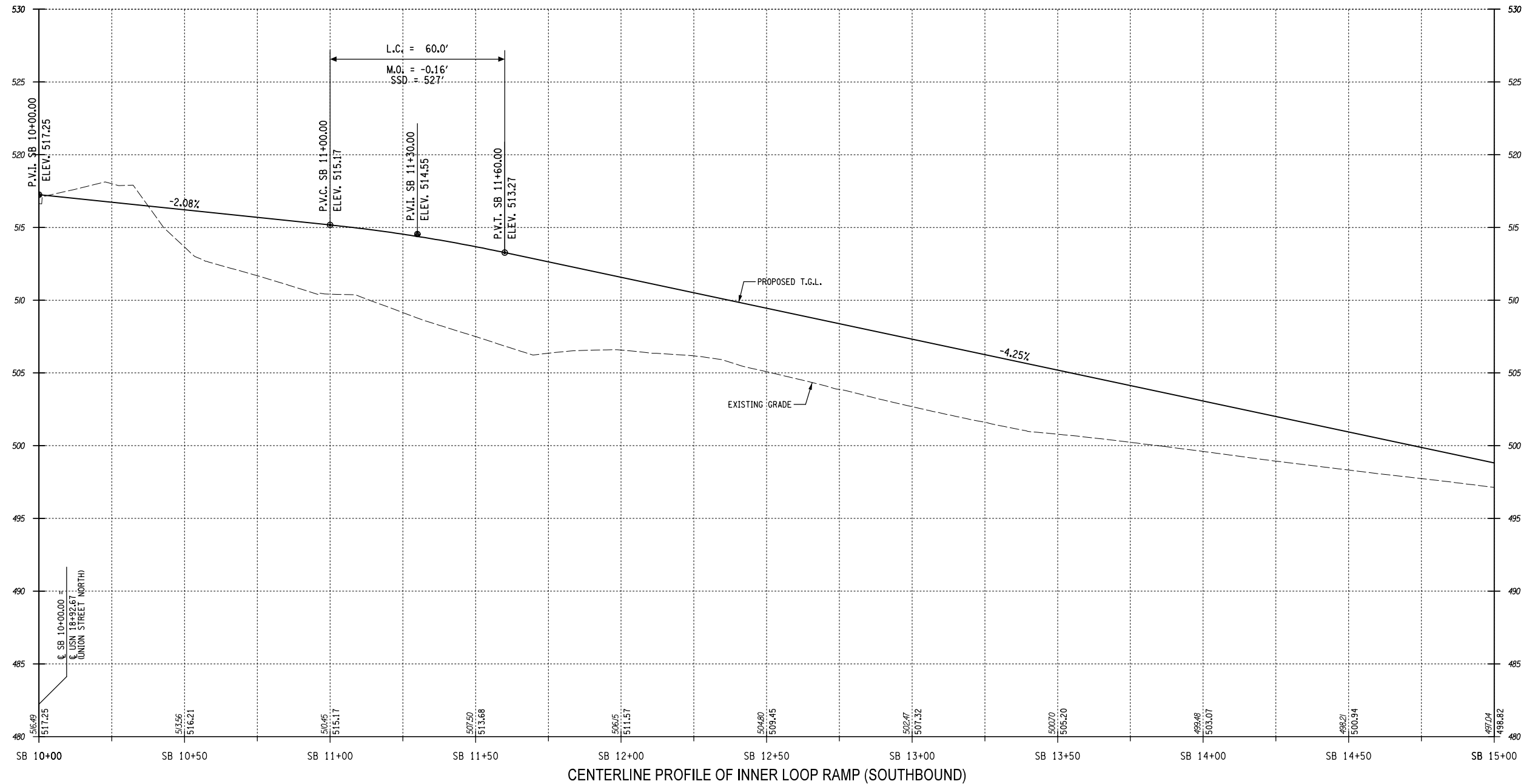

CENTERLINE PROFILE OF INNER LOOP RAMP (SOUTHBOUND)

IT IS A VIOLATION OF LAW FOR ANY PERSON, UNLESS THEY ARE ACTING UNDER THE DIRECTION OF A LICENSED PROFESSIONAL ENGINEER, ARCHITECT, LANDSCAPE ARCHITECT, OR LAND SURVEYOR, TO ALTER AN ITEM IN ANY WAY. IF AN ITEM BEARING THE STAMP OF A LICENSED PROFESSIONAL IS ALTERED, THE ALTERING ENGINEER, ARCHITECT, LANDSCAPE ARCHITECT, OR LAND SURVEYOR SHALL STAMP THE DOCUMENT AND INCLUDE THE NOTATION "ALTERED BY" FOLLOWED BY THEIR SIGNATURE, THE DATE OF SUCH ALTERATION, AND A SPECIFIC DESCRIPTION OF THE ALTERATION.

Permit-Seal

Consultants



61 Commercial St, Suite 100
Rochester, NY 14614
www.stantec.com

The Contractor shall verify and be responsible for all dimensions. DO NOT scale the drawing - any errors or omissions shall be reported to Stantec without delay.
The Copyrights to all designs and drawings are the property of Stantec. Reproduction or use for any purpose other than that authorized by Stantec is forbidden.

Client/Project

CITY OF ROCHESTER

INNER LOOP EAST TRANSFORMATION PROJECT
S. CLINTON AVENUE TO EAST MAIN STREET
P.I.N. 4940.T7 D017599

ROCHESTER, NEW YORK

File Name:

14.03
YY.MM.DD
Dwn. Chkd. Dsgn.

Title

GENERAL PROFILE

Project No.
192500295

Scale
H: 1"=40' V: 1"=8'

Drawing No.

Sheet

Revision

PR-14

XXX of XXX

0

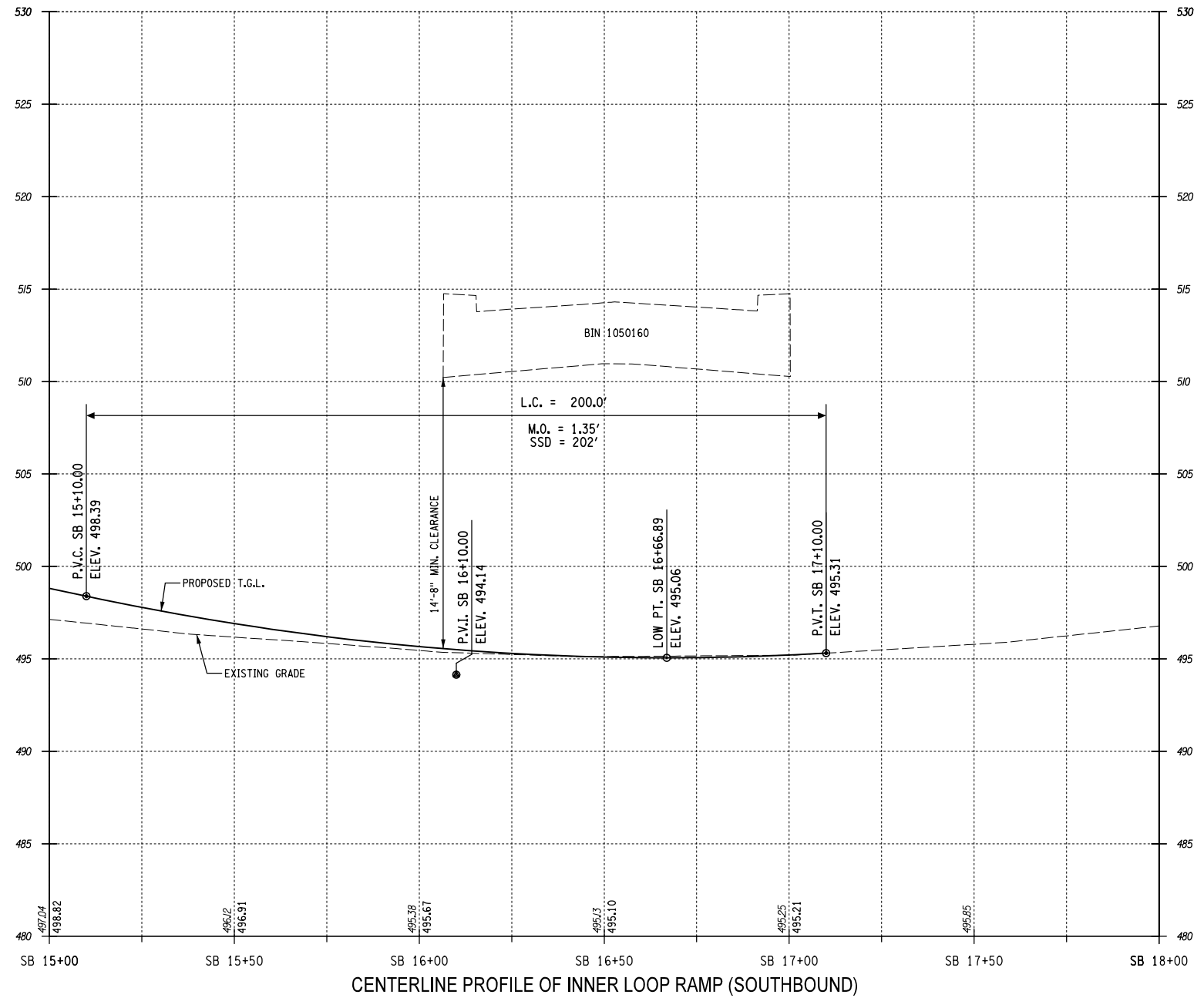

Design File: U:\192500295\Technical\Drawings\Plan Set\PR-15.dgn
 Date Plotted: 3/27/2014 3:06:55 PM
 Plotted By: sommer

IT IS A VIOLATION OF LAW FOR ANY PERSON, UNLESS THEY ARE ACTING UNDER THE DIRECTION OF A LICENSED PROFESSIONAL ENGINEER, ARCHITECT, LANDSCAPE ARCHITECT, OR LAND SURVEYOR, TO ALTER AN ITEM IN ANY WAY. IF AN ITEM BEARING THE STAMP OF A LICENSED PROFESSIONAL IS ALTERED, THE ALTERING ENGINEER, ARCHITECT, LANDSCAPE ARCHITECT, OR LAND SURVEYOR SHALL STAMP THE DOCUMENT AND INCLUDE THE NOTATION "ALTERED BY" FOLLOWED BY THEIR SIGNATURE, THE DATE OF SUCH ALTERATION, AND A SPECIFIC DESCRIPTION OF THE ALTERATION.				Permit-Seal	Consultants	 61 Commercial St, Suite 100 Rochester, NY 14614 www.stantec.com	Client/Project CITY OF ROCHESTER INNER LOOP EAST TRANSFORMATION PROJECT S. CLINTON AVENUE TO EAST MAIN STREET P.I.N. 4940.T7 D017599 ROCHESTER, NEW YORK	Title GENERAL PROFILE																																																																																												
<table border="1"> <thead> <tr> <th>Revision</th> <th>By</th> <th>Appd.</th> <th>YY.MM.DD</th> </tr> </thead> <tbody> <tr><td> </td><td> </td><td> </td><td> </td></tr> <tr><td> </td><td> </td><td> </td><td> </td></tr> <tr><td> </td><td> </td><td> </td><td> </td></tr> <tr><td> </td><td> </td><td> </td><td> </td></tr> <tr><td> </td><td> </td><td> </td><td> </td></tr> <tr><td> </td><td> </td><td> </td><td> </td></tr> <tr><td> </td><td> </td><td> </td><td> </td></tr> <tr><td> </td><td> </td><td> </td><td> </td></tr> <tr><td> </td><td> </td><td> </td><td> </td></tr> <tr><td> </td><td> </td><td> </td><td> </td></tr> </tbody> </table>	Revision	By	Appd.						YY.MM.DD																																									<table border="1"> <thead> <tr> <th>Issued</th> <th>By</th> <th>Appd.</th> <th>YY.MM.DD</th> </tr> </thead> <tbody> <tr><td> </td><td> </td><td> </td><td> </td></tr> <tr><td> </td><td> </td><td> </td><td> </td></tr> <tr><td> </td><td> </td><td> </td><td> </td></tr> <tr><td> </td><td> </td><td> </td><td> </td></tr> <tr><td> </td><td> </td><td> </td><td> </td></tr> <tr><td> </td><td> </td><td> </td><td> </td></tr> <tr><td> </td><td> </td><td> </td><td> </td></tr> <tr><td> </td><td> </td><td> </td><td> </td></tr> <tr><td> </td><td> </td><td> </td><td> </td></tr> <tr><td> </td><td> </td><td> </td><td> </td></tr> </tbody> </table>	Issued	By	Appd.	YY.MM.DD																																									<table border="1"> <thead> <tr> <th>Project No.</th> <th>Scale</th> </tr> </thead> <tbody> <tr> <td>192500295</td> <td>H: 1"=40' V: 1"=8'</td> </tr> <tr> <th>Drawing No.</th> <th>Sheet</th> <th>Revision</th> </tr> <tr> <td>PR-15</td> <td>XXX of XXX</td> <td>0</td> </tr> </tbody> </table>	Project No.	Scale	192500295	H: 1"=40' V: 1"=8'	Drawing No.
Revision	By	Appd.	YY.MM.DD																																																																																																	
Issued	By	Appd.	YY.MM.DD																																																																																																	
Project No.	Scale																																																																																																			
192500295	H: 1"=40' V: 1"=8'																																																																																																			
Drawing No.	Sheet	Revision																																																																																																		
PR-15	XXX of XXX	0																																																																																																		

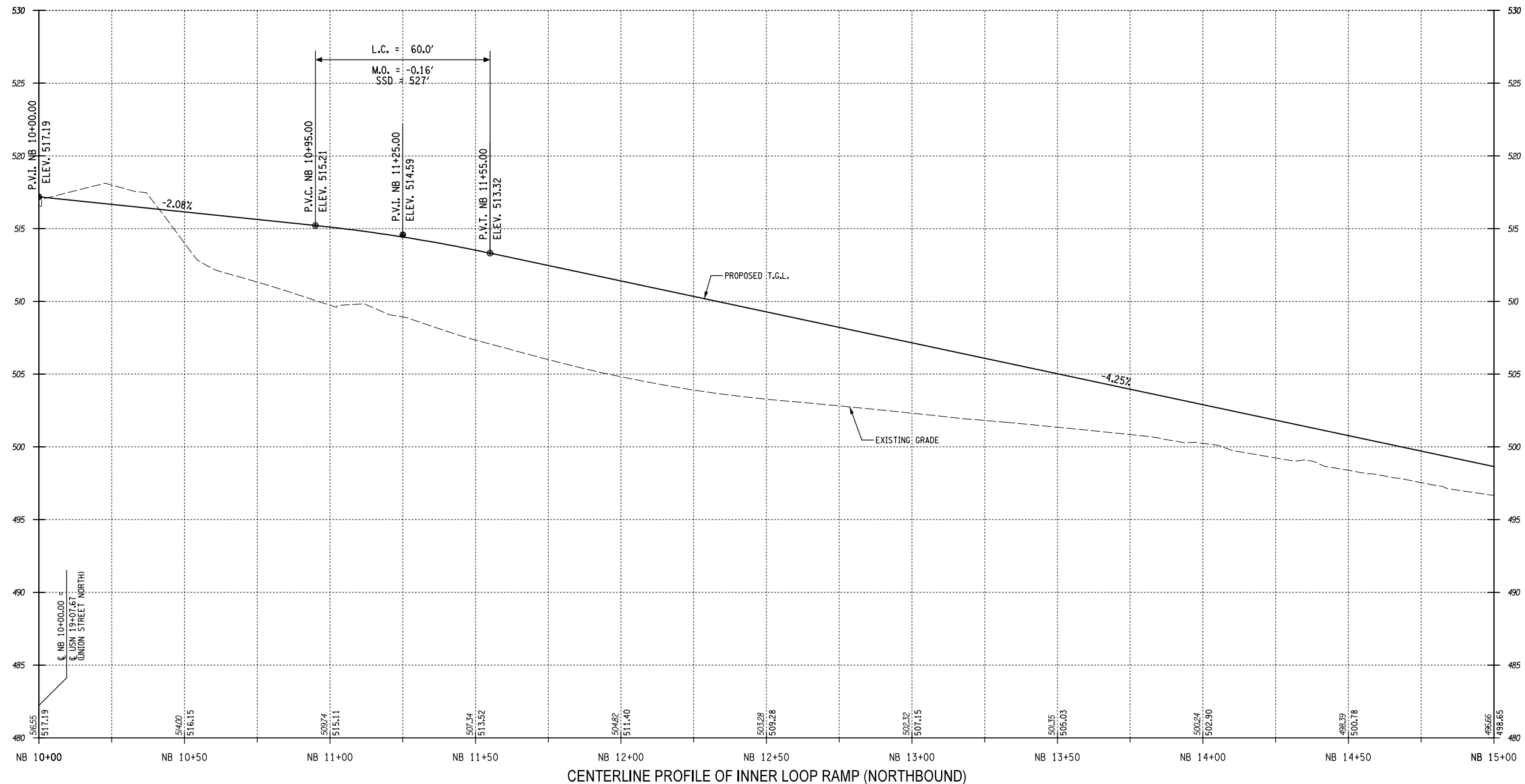

CENTERLINE PROFILE OF INNER LOOP RAMP (NORTHBOUND)

Design File: \\s0220285\Technical\Drawings\Plan Set\VR\PR-16.dgn
 Date/Time: 3/27/2014 3:06:55 PM
 Plotted By: somerster

Revision			By			Appd.			Issued		
Rev.	Description	Date	By	Appd.	Issued	By	Appd.	Issued	By	Appd.	Issued

ORIGINAL SHEET - ANSID HOME

Permit-Seal

Consultants

61 Commercial St, Suite 100
 Rochester, NY 14614
 www.stantec.com
 The Contractor shall verify and be responsible for all dimensions. DO NOT scale the drawing - any errors or omissions shall be reported to Stantec without delay.
 The Copyrights to all designs and drawings are the property of Stantec. Reproduction or use for any purpose other than that authorized by Stantec is forbidden.

Client/Project
 CITY OF ROCHESTER
 INNER LOOP EAST TRANSFORMATION PROJECT
 S. CLINTON AVENUE TO EAST MAIN STREET
 P.I.N. 4940.T7 D017599
 ROCHESTER, NEW YORK

File Name: _____
 Dwn. Chkd. Dsgn. 14.03 YY.MM.DD

Title
 GENERAL PROFILE

Project No. 192500295
 Drawing No. PR-16

Scale: H: 1"=40' V: 1"=8'
 Sheet: XXX of XXX
 Revision: 0

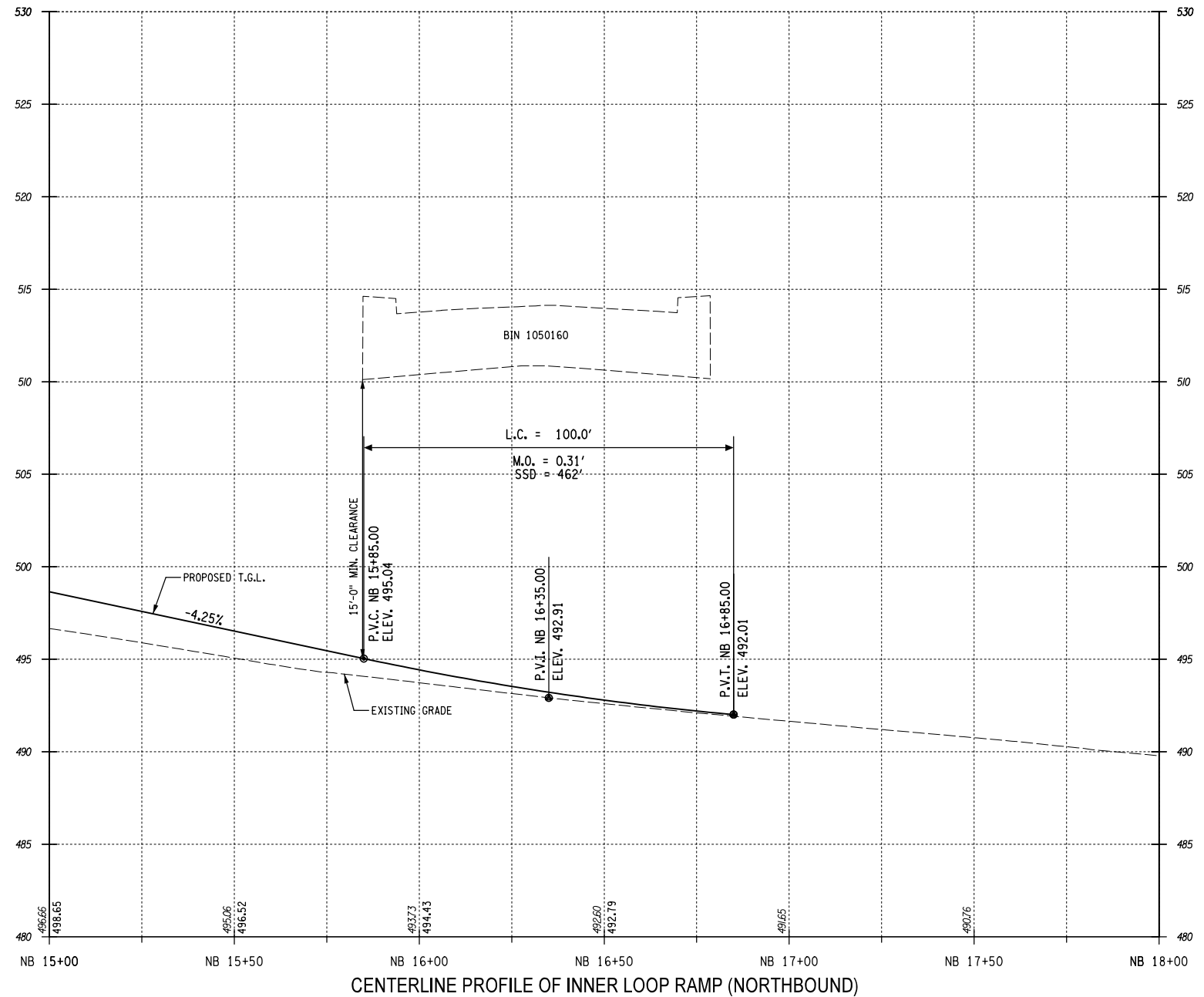

Design File: U:\192500295\Technical\Drawings\Plan Set\PR-17.dgn
 Date Plotted: 3/27/2014 3:06:56 PM
 Plotted By: sromer

Revision	By	Appd.	YY.MM.DD	Issued	By	Appd.	YY.MM.DD

Permit-Seal

Consultants



Stantec

61 Commercial St, Suite 100
 Rochester, NY 14614
 www.stantec.com

The Contractor shall verify and be responsible for all dimensions. DO NOT scale the drawing - any errors or omissions shall be reported to Stantec without delay.

The Copyrights to all designs and drawings are the property of Stantec. Reproduction or use for any purpose other than that authorized by Stantec is forbidden.

Client/Project
CITY OF ROCHESTER
 INNER LOOP EAST TRANSFORMATION PROJECT
 S. CLINTON AVENUE TO EAST MAIN STREET
 P.I.N. 4940.T7 D017599
 ROCHESTER, NEW YORK

File Name: _____
 Dwn. Chkd. Dsgn. 14.03
 YY.MM.DD

Title
GENERAL PROFILE

Project No. 192500295 Scale H: 1"=40' V: 1"=8'

Drawing No. PR-17 Sheet XXX of XXX Revision 0

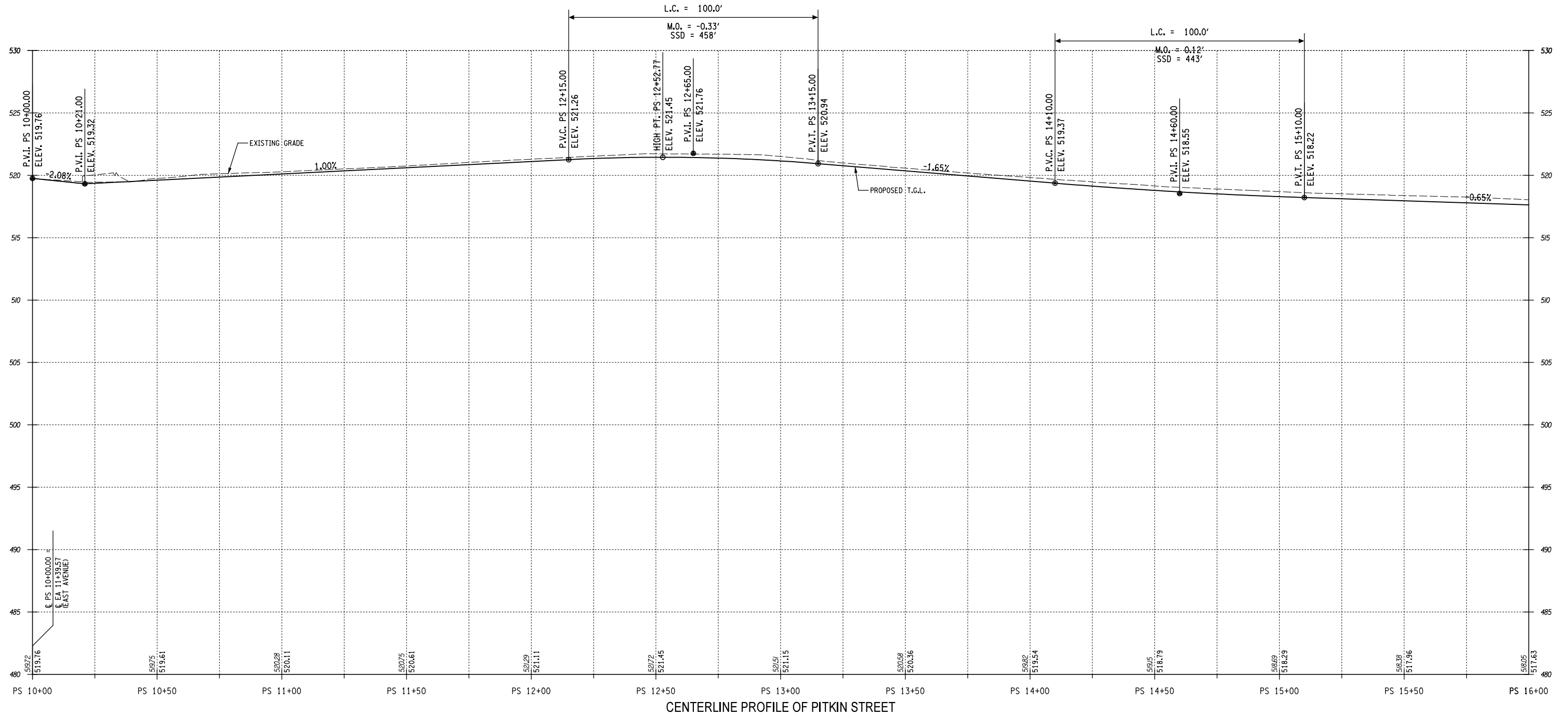

CENTERLINE PROFILE OF PITKIN STREET

IT IS A VIOLATION OF LAW FOR ANY PERSON, UNLESS THEY ARE ACTING UNDER THE DIRECTION OF A LICENSED PROFESSIONAL ENGINEER, ARCHITECT, LANDSCAPE ARCHITECT, OR LAND SURVEYOR, TO ALTER AN ITEM IN ANY WAY. IF AN ITEM BEARING THE STAMP OF A LICENSED PROFESSIONAL IS ALTERED, THE ALTERING ENGINEER, ARCHITECT, LANDSCAPE ARCHITECT, OR LAND SURVEYOR SHALL STAMP THE DOCUMENT AND INCLUDE THE NOTATION "ALTERED BY" FOLLOWED BY THEIR SIGNATURE, THE DATE OF SUCH ALTERATION, AND A SPECIFIC DESCRIPTION OF THE ALTERATION.

Revision	By	Appd.	YY.MM.DD

Issued	By	Appd.	YY.MM.DD

Permit-Seal

Consultants

Stantec

61 Commercial St, Suite 100
 Rochester, NY 14614
 www.stantec.com

The Contractor shall verify and be responsible for all dimensions. DO NOT scale the drawing - any errors or omissions shall be reported to Stantec without delay.

The Copyrights to all designs and drawings are the property of Stantec. Reproduction or use for any purpose other than that authorized by Stantec is forbidden.

Client/Project
 CITY OF ROCHESTER
 INNER LOOP EAST TRANSFORMATION PROJECT
 S. CLINTON AVENUE TO EAST MAIN STREET
 P.I.N. 4940.T7 D017599
 ROCHESTER, NEW YORK

File Name: _____
 Dwn. Chkd. Dsgn. 14.03
 YY.MM.DD

Title
 GENERAL PROFILE

Project No. 192500295 Scale H: 1"=40' V: 1"=8'

Drawing No. PR-18 Sheet XXX of XXX Revision 0

Design File: U:\192500295\Transportation\Design\Drawings\Plan Set\PR-18.dgn
 Date Plotted: 3/6/2014 3:06:57 PM
 Plotted By: sommer

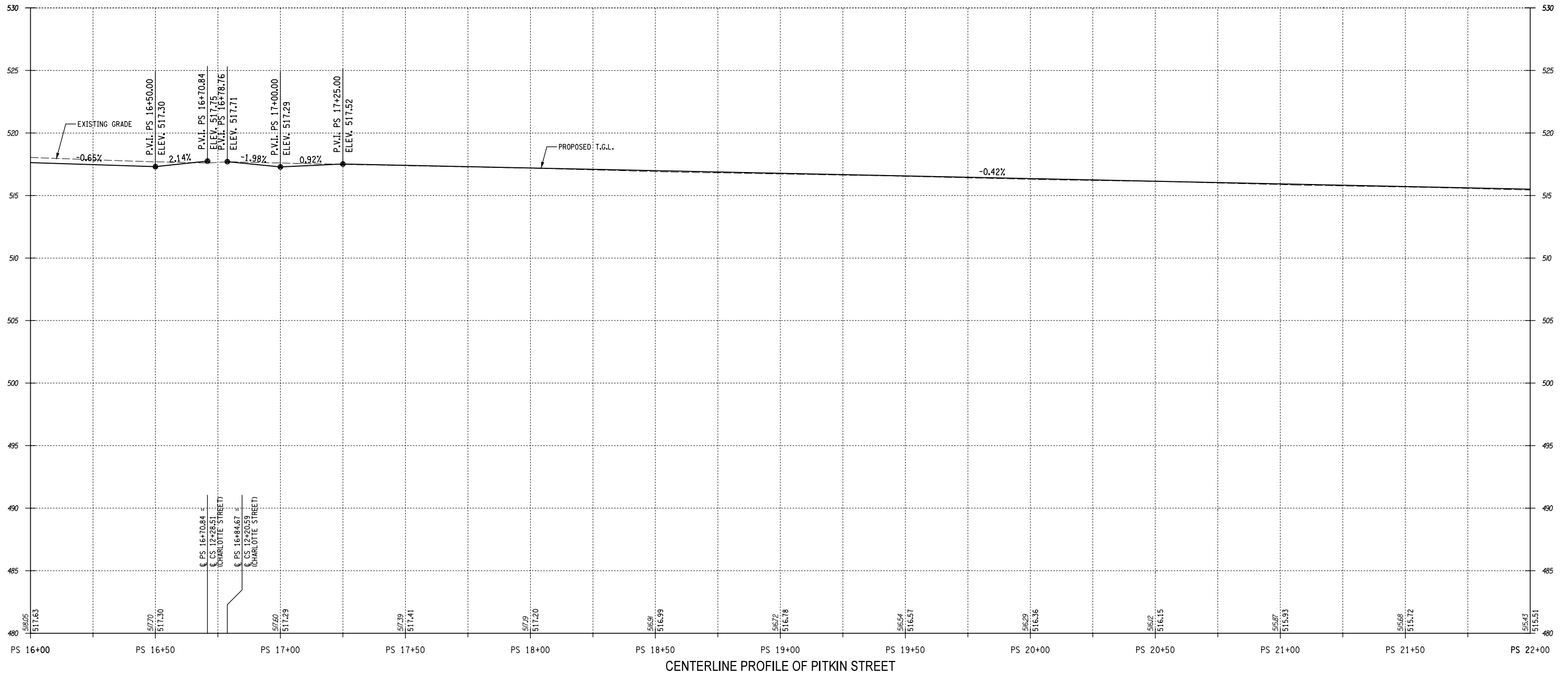

CENTERLINE PROFILE OF PITKIN STREET

Design File: U:\192500295\Technical\Drawings\Plan Set\PR-19.dgn
 Date Plotted: 3/27/2014 3:06:57 PM
 Plotted By: sommer

<small>IT IS A VIOLATION OF LAW FOR ANY PERSON, UNLESS THEY ARE ACTING UNDER THE DIRECTION OF A LICENSED PROFESSIONAL ENGINEER, ARCHITECT, LANDSCAPE ARCHITECT, OR LAND SURVEYOR, TO ALTER AN ITEM IN ANY WAY. IF AN ITEM BEARING THE STAMP OF A LICENSED PROFESSIONAL IS ALTERED, THE ALTERING ENGINEER, ARCHITECT, LANDSCAPE ARCHITECT, OR LAND SURVEYOR SHALL STAMP THE DOCUMENT AND INCLUDE THE NOTATION "ALTERED BY" FOLLOWED BY THEIR SIGNATURE, THE DATE OF SUCH ALTERATION, AND A SPECIFIC DESCRIPTION OF THE ALTERATION.</small>			
Permit-Seal			
Consultants			
Revision	By	Appd.	YY.MM.DD
Issued	By	Appd.	YY.MM.DD



The Contractor shall verify and be responsible for all dimensions. DO NOT scale the drawing - any errors or omissions shall be reported to Stantec without delay.
 The Copyrights to all designs and drawings are the property of Stantec. Reproduction or use for any purpose other than that authorized by Stantec is forbidden.

Client/Project
CITY OF ROCHESTER
 INNER LOOP EAST TRANSFORMATION PROJECT
 S. CLINTON AVENUE TO EAST MAIN STREET
 P.I.N. 4940.T7 D017599
 ROCHESTER, NEW YORK

File Name: _____
 Dwn. Chkd. Dsgn. 14.03 YY.MM.DD

Title
GENERAL PROFILE

Project No. 192500295 Scale H: 1"=40' V: 1"=8'

Drawing No. PR-19 Sheet XXX of XXX Revision 0

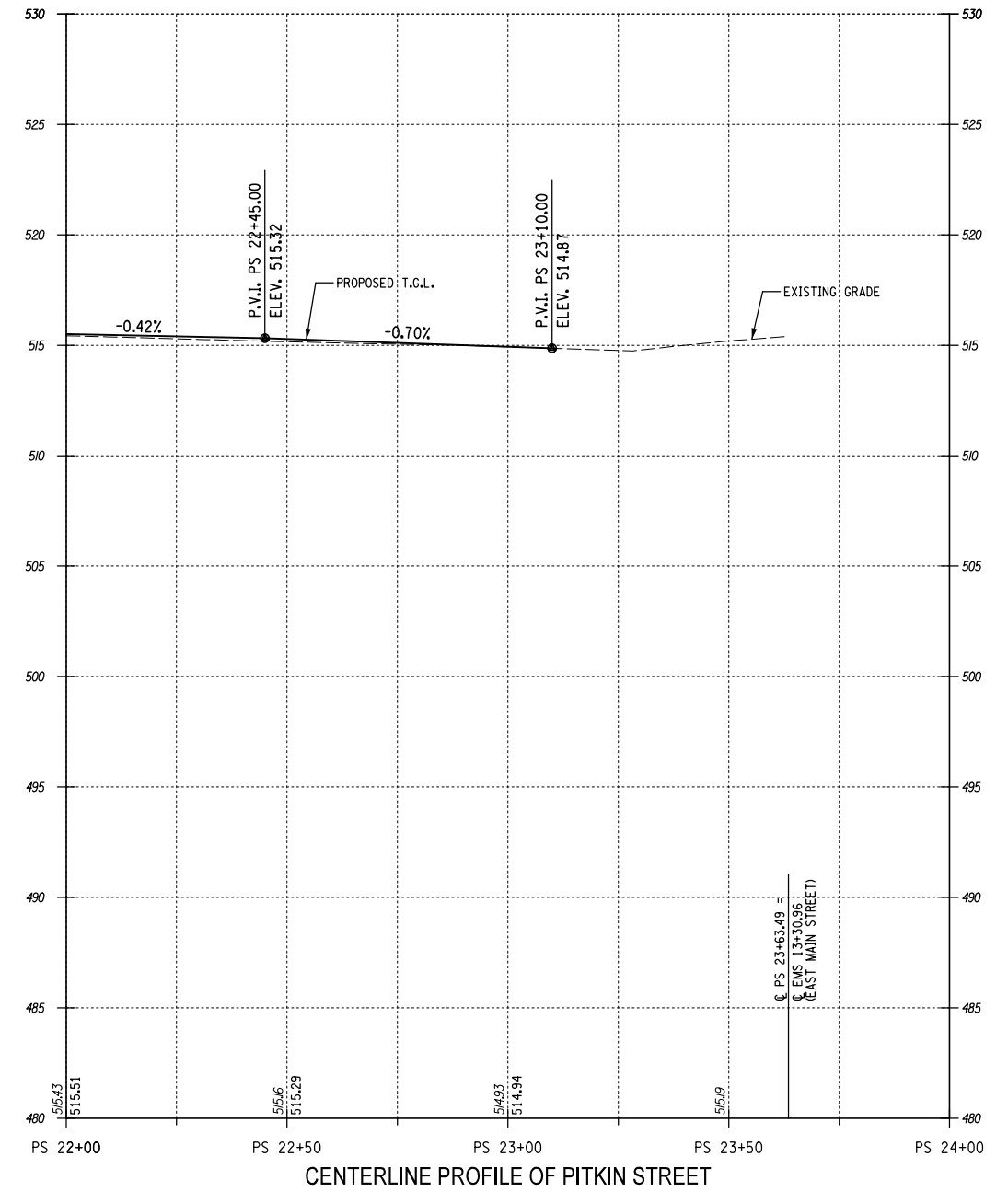

CENTERLINE PROFILE OF PITKIN STREET

Design File: I:\192500295\Technical\Drawings\Plan Set\PR-20.dgn
 Date Plotted: 3/27/2014 3:06:58 PM
 Plotted By: srombler

IT IS A VIOLATION OF LAW FOR ANY PERSON, UNLESS THEY ARE ACTING UNDER THE DIRECTION OF A LICENSED PROFESSIONAL ENGINEER, ARCHITECT, LANDSCAPE ARCHITECT, OR LAND SURVEYOR, TO ALTER AN ITEM IN ANY WAY. IF AN ITEM BEARING THE STAMP OF A LICENSED PROFESSIONAL IS ALTERED, THE ALTERING ENGINEER, ARCHITECT, LANDSCAPE ARCHITECT, OR LAND SURVEYOR SHALL STAMP THE DOCUMENT AND INCLUDE THE NOTATION "ALTERED BY" FOLLOWED BY THEIR SIGNATURE, THE DATE OF SUCH ALTERATION, AND A SPECIFIC DESCRIPTION OF THE ALTERATION.

Permit-Seal

Consultants

61 Commercial St, Suite 100
 Rochester, NY 14614
 www.stantec.com

Client/Project
 CITY OF ROCHESTER
 INNER LOOP EAST TRANSFORMATION PROJECT
 S. CLINTON AVENUE TO EAST MAIN STREET
 P.I.N. 4940.T7 D017599
 ROCHESTER, NEW YORK

Title
 GENERAL PROFILE

Project No. 192500295 Scale H: 1"=40' V: 1"=8'

Drawing No. Sheet Revision

Revision	By	Appd.	YY.MM.DD

Issued	By	Appd.	YY.MM.DD

File Name:	Dwn.	Chkd.	Dsgn.	14.03

PR-20 XXX of XXX 0

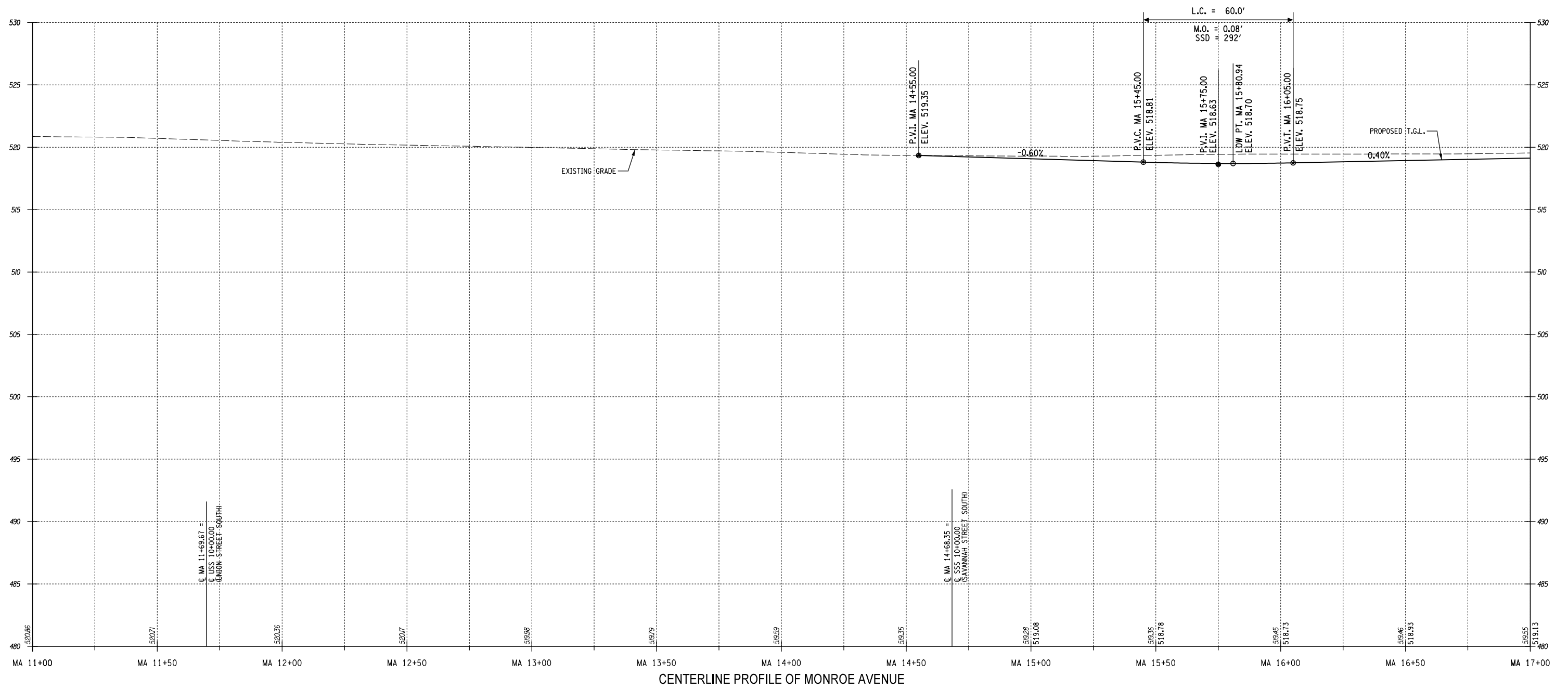

CENTERLINE PROFILE OF MONROE AVENUE

IT IS A VIOLATION OF LAW FOR ANY PERSON, UNLESS THEY ARE ACTING UNDER THE DIRECTION OF A LICENSED PROFESSIONAL ENGINEER, ARCHITECT, LANDSCAPE ARCHITECT, OR LAND SURVEYOR, TO ALTER AN ITEM IN ANY WAY. IF AN ITEM BEARING THE STAMP OF A LICENSED PROFESSIONAL IS ALTERED, THE ALTERING ENGINEER, ARCHITECT, LANDSCAPE ARCHITECT, OR LAND SURVEYOR SHALL STAMP THE DOCUMENT AND INCLUDE THE NOTATION "ALTERED BY" FOLLOWED BY THEIR SIGNATURE, THE DATE OF SUCH ALTERATION, AND A SPECIFIC DESCRIPTION OF THE ALTERATION.

Revision	By	Appd.	YY.MM.DD	Issued	By	Appd.	YY.MM.DD

Permit-Seal

Consultants

Stantec

61 Commercial St, Suite 100
Rochester, NY 14614
www.stantec.com

The Contractor shall verify and be responsible for all dimensions. DO NOT scale the drawing - any errors or omissions shall be reported to Stantec without delay.

The Copyrights to all designs and drawings are the property of Stantec. Reproduction or use for any purpose other than that authorized by Stantec is forbidden.

Client/Project
CITY OF ROCHESTER

INNER LOOP EAST TRANSFORMATION PROJECT
S. CLINTON AVENUE TO EAST MAIN STREET
P.I.N. 4940.T7 D017599

ROCHESTER, NEW YORK

File Name: _____

Dwn. Chkd. Dsgn. 14.03
YY.MM.DD

Title
GENERAL PROFILE

Project No. 192500295 Scale H: 1"=40' V: 1"=8'

Drawing No. PR-21 Sheet XXX of XXX Revision 0

Design File: \\s\192500295\Technical\Drawings\Plan Set\PR-21.dgn
Date Plotted: 3/27/2014 3:56:59 PM
Plotted By: sromeler

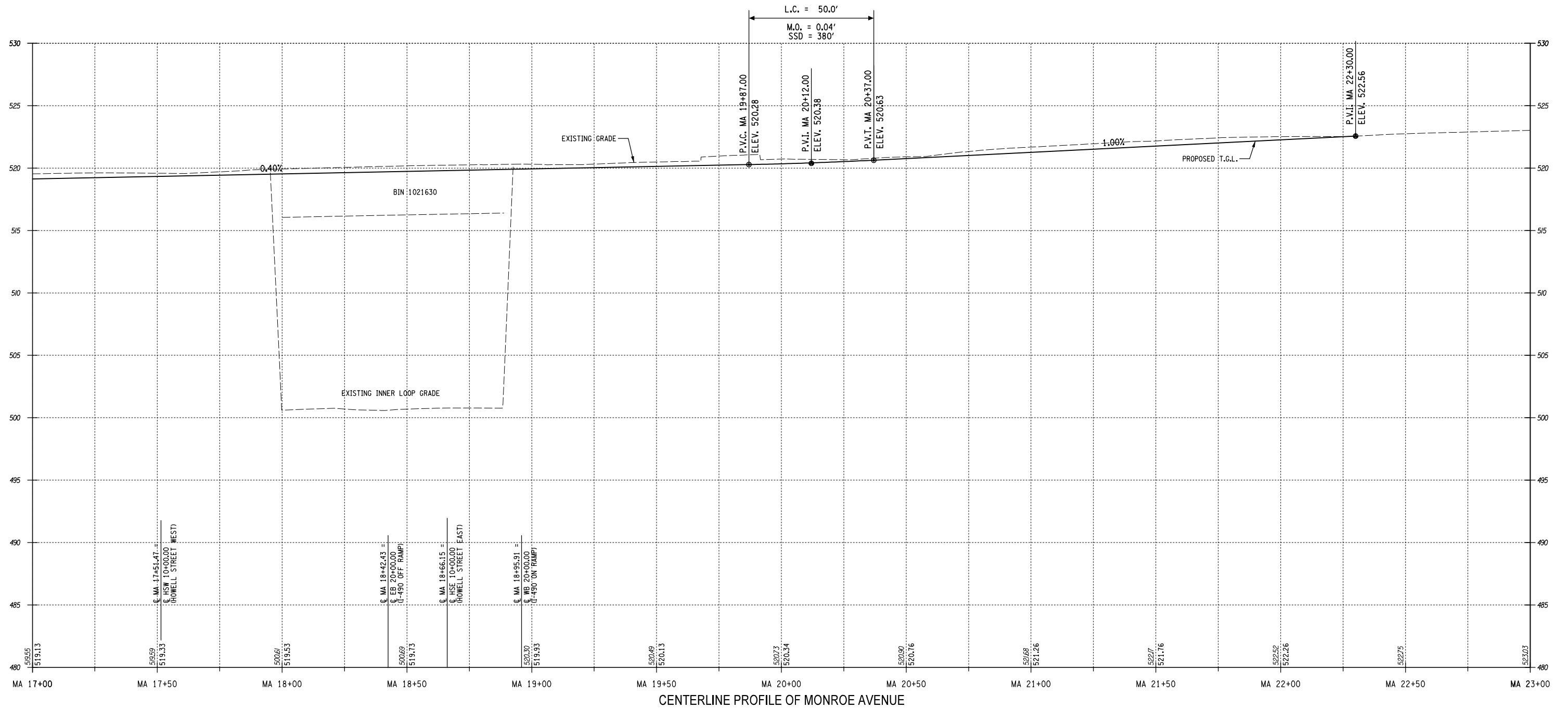

CENTERLINE PROFILE OF MONROE AVENUE

Design File: \\s020285\Technical\Drawings\Plan Set\PR-22.dgn
 Date Plotted: 3/27/2014 3:07:00 PM
 Plotted By: somelster

Permit-Seal				Consultants			
Revision	By	Appd.	YY.MM.DD	Issued	By	Appd.	YY.MM.DD

Permit-Seal		Consultants	

61 Commercial St, Suite 100
 Rochester, NY 14614
 www.stantec.com

The Contractor shall verify and be responsible for all dimensions. DO NOT scale the drawing - any errors or omissions shall be reported to Stantec without delay.

The Copyrights to all designs and drawings are the property of Stantec. Reproduction or use for any purpose other than that authorized by Stantec is forbidden.

Client/Project
 CITY OF ROCHESTER
 INNER LOOP EAST TRANSFORMATION PROJECT
 S. CLINTON AVENUE TO EAST MAIN STREET
 P.I.N. 4940.T7 D017599
 ROCHESTER, NEW YORK

File Name: _____
 Dwn. Chkd. Dsgn. 14.03 YY.MM.DD

Title		
GENERAL PROFILE		
Project No. 192500295	Scale H: 1"=40' V: 1"=8'	
Drawing No. PR-22	Sheet XXX of XXX	Revision 0

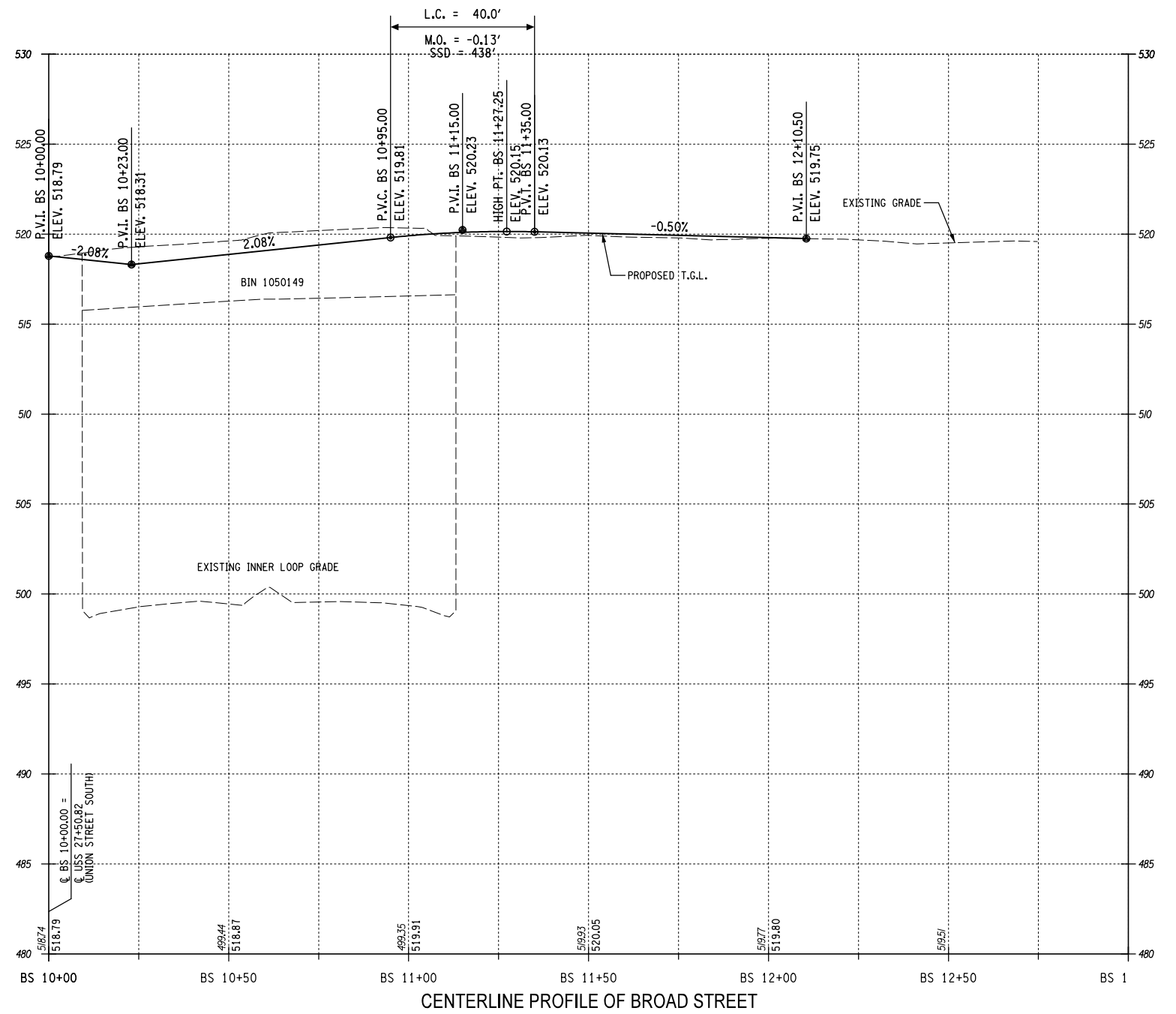

Design File: U:\192500295\Technical\Drawings\Plan Set\PR-23.dgn
 Date Plotted: 3/27/2014 3:07:00 PM
 Plotted By: somelster

Revision				Issued			
By	Appd.	YY.MM.DD		By	Appd.	YY.MM.DD	

Permit-Seal

Consultants

Stantec

61 Commercial St, Suite 100
 Rochester, NY 14614
 www.stantec.com

The Contractor shall verify and be responsible for all dimensions. DO NOT scale the drawing - any errors or omissions shall be reported to Stantec without delay.

The Copyrights to all designs and drawings are the property of Stantec. Reproduction or use for any purpose other than that authorized by Stantec is forbidden.

Client/Project
 CITY OF ROCHESTER
 INNER LOOP EAST TRANSFORMATION PROJECT
 S. CLINTON AVENUE TO EAST MAIN STREET
 P.I.N. 4940.T7 D017599
 ROCHESTER, NEW YORK

File Name: _____
 Dwn. Chkd. Dsgn. 14.03
 YY.MM.DD

Title
 GENERAL PROFILE

Project No. 192500295
 Scale H: 1"=40' V: 1"=8'

Drawing No. PR-23
 Sheet XXX of XXX
 Revision 0

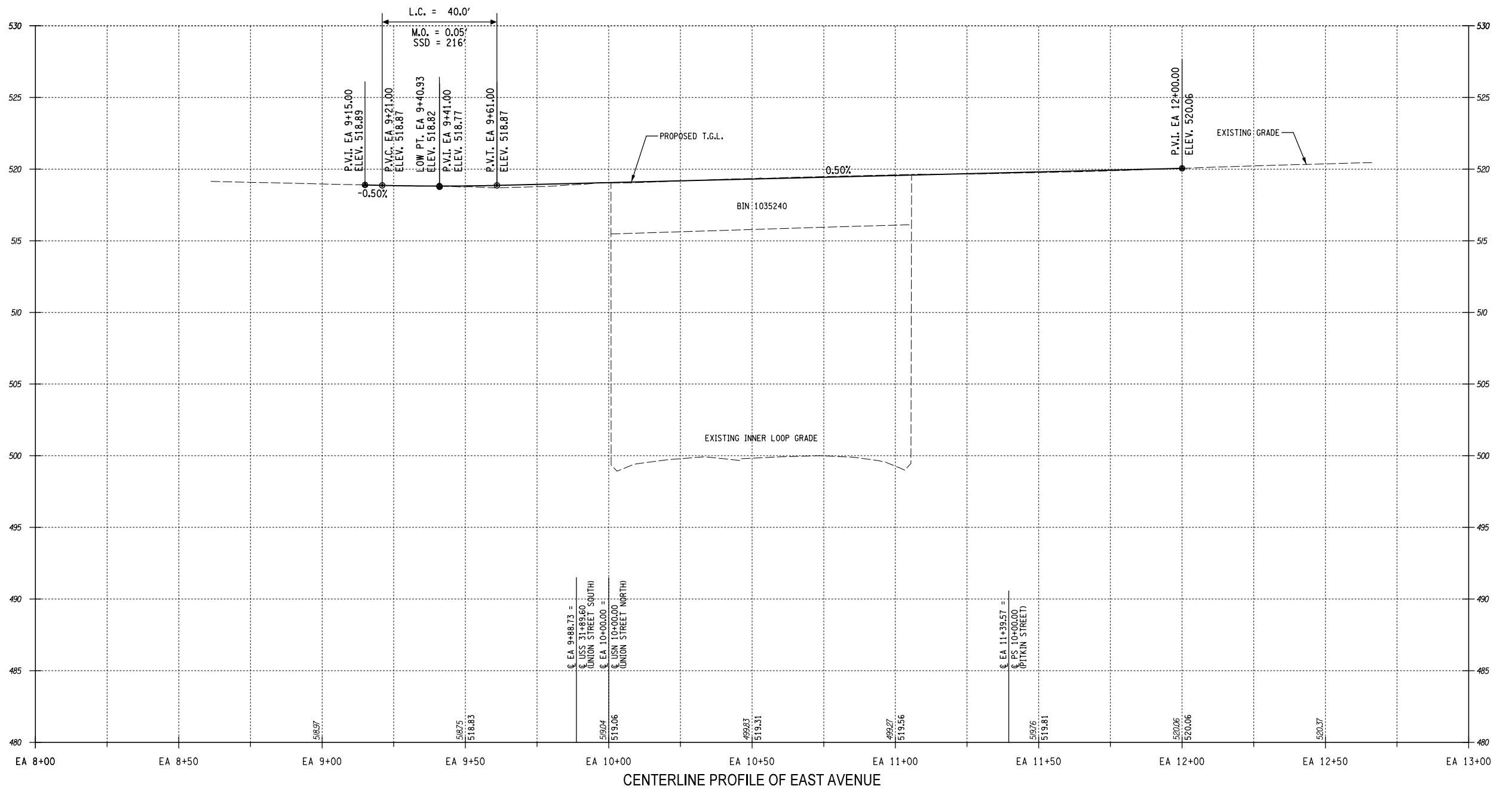

Design File: U:\192500295\Technical\Drawings\Plan Set\PR-24.dgn
 Date Plotted: 3/27/2014 3:07:01 PM
 Plotted By: somester

Revision	By	Appd.	YY.MM.DD	Issued	By	Appd.	YY.MM.DD

Permit-Seal

Consultants

Stantec

61 Commercial St., Suite 100
 Rochester, NY 14614
 www.stantec.com

The Contractor shall verify and be responsible for all dimensions. DO NOT scale the drawing - any errors or omissions shall be reported to Stantec without delay.

The Copyrights to all designs and drawings are the property of Stantec. Reproduction or use for any purpose other than that authorized by Stantec is forbidden.

Client/Project
 CITY OF ROCHESTER
 INNER LOOP EAST TRANSFORMATION PROJECT
 S. CLINTON AVENUE TO EAST MAIN STREET
 P.I.N. 4940.T7 D017599
 ROCHESTER, NEW YORK

File Name: _____
 Dwn. Chkd. Dsgn. 14.03
 YY.MM.DD

Title
 GENERAL PROFILE

Project No. 192500295
 Scale H: 1"=40' V: 1"=8'

Drawing No. PR-24
 Sheet XXX of XXX
 Revision 0

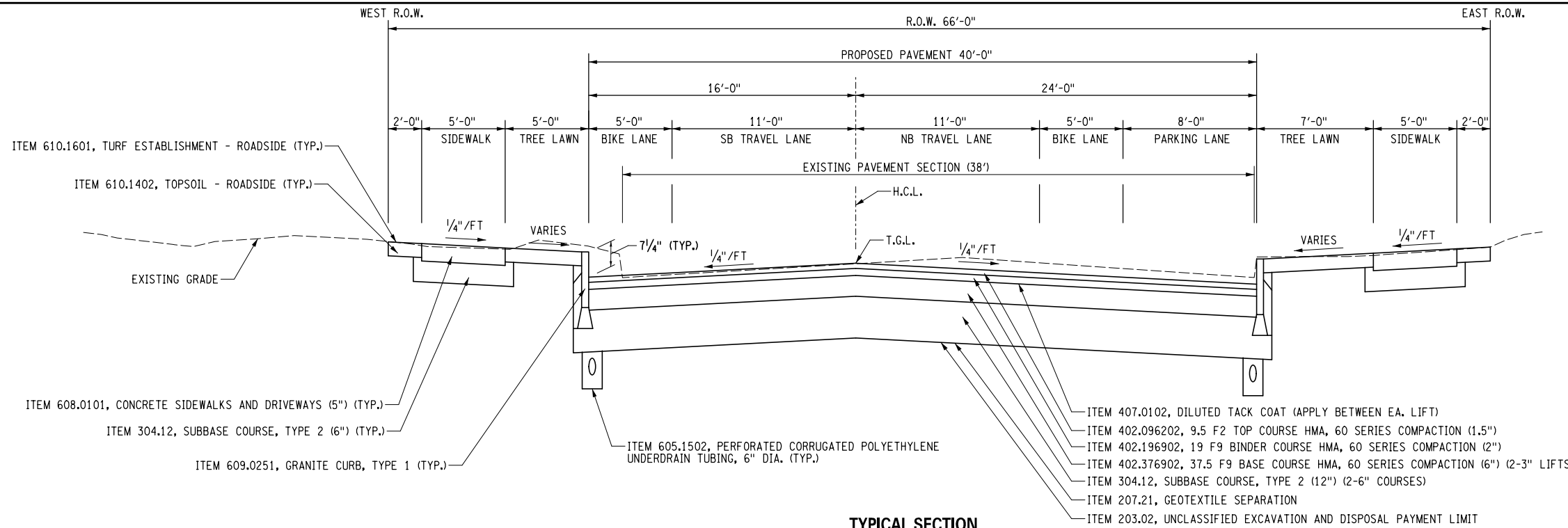

TYPICAL SECTION
SOUTH UNION STREET - 2 LANE ROAD WITH BICYCLE LANES
 (STA. USS 10+50 TO STA. USS 15+50)

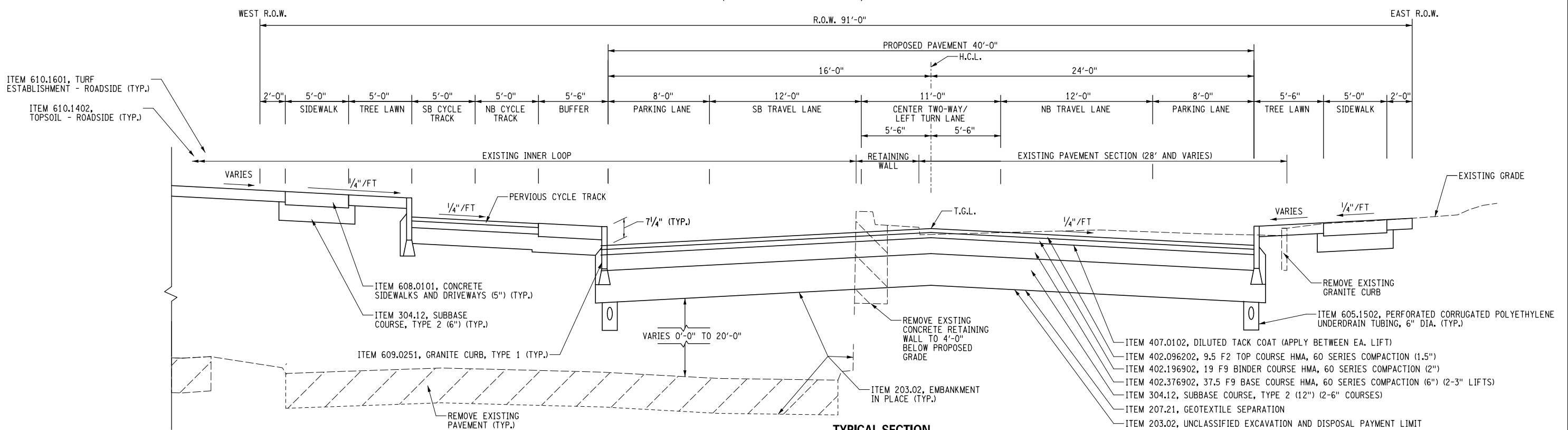

TYPICAL SECTION
SOUTH UNION STREET - 3 LANE ROAD WITH CYCLE TRACK
 (STA. USS 15+50 TO STA. USS 28+00)

IT IS A VIOLATION OF LAW FOR ANY PERSON, UNLESS THEY ARE ACTING UNDER THE DIRECTION OF A LICENSED PROFESSIONAL ENGINEER, ARCHITECT, LANDSCAPE ARCHITECT, OR LAND SURVEYOR, TO ALTER AN ITEM IN ANY WAY. IF AN ITEM BEARING THE STAMP OF A LICENSED PROFESSIONAL IS ALTERED, THE ALTERING ENGINEER, ARCHITECT, LANDSCAPE ARCHITECT, OR LAND SURVEYOR SHALL STAMP THE DOCUMENT AND INCLUDE THE NOTATION "ALTERED BY" FOLLOWED BY THEIR SIGNATURE, THE DATE OF SUCH ALTERATION, AND A SPECIFIC DESCRIPTION OF THE ALTERATION.

Permit-Seal

Consultants



61 Commercial St. Suite 100
 Rochester, NY 14614
 www.stantec.com

The Contractor shall verify and be responsible for all dimensions. DO NOT scale the drawing - any errors or omissions shall be reported to Stantec without delay.
 The Copyrights to all designs and drawings are the property of Stantec. Reproduction or use for any purpose other than that authorized by Stantec is forbidden.

Client/Project
 CITY OF ROCHESTER
 INNER LOOP EAST TRANSFORMATION PROJECT
 S. CLINTON AVENUE TO EAST MAIN STREET
 P.I.N. 4940.T7 D017599
 ROCHESTER, NEW YORK

Title
 TYPICAL SECTION
 UNION STREET

Project No. 192500295 Scale N.T.S.
 Drawing No. TS-1 Sheet XXX of XXX Revision 0

Revision	By	Appd.	YY.MM.DD	Issued	By	Appd.	YY.MM.DD

File Name: _____ Dwn. Chkd. Dsgn. 14.03 YY.MM.DD

Design File: U:\192500295\Transportation\Preparation\Drawings\Plan Set\13-01.dgn
 Date/Time: 3/27/2014 9:48:11 AM
 Plotted By: cdbark

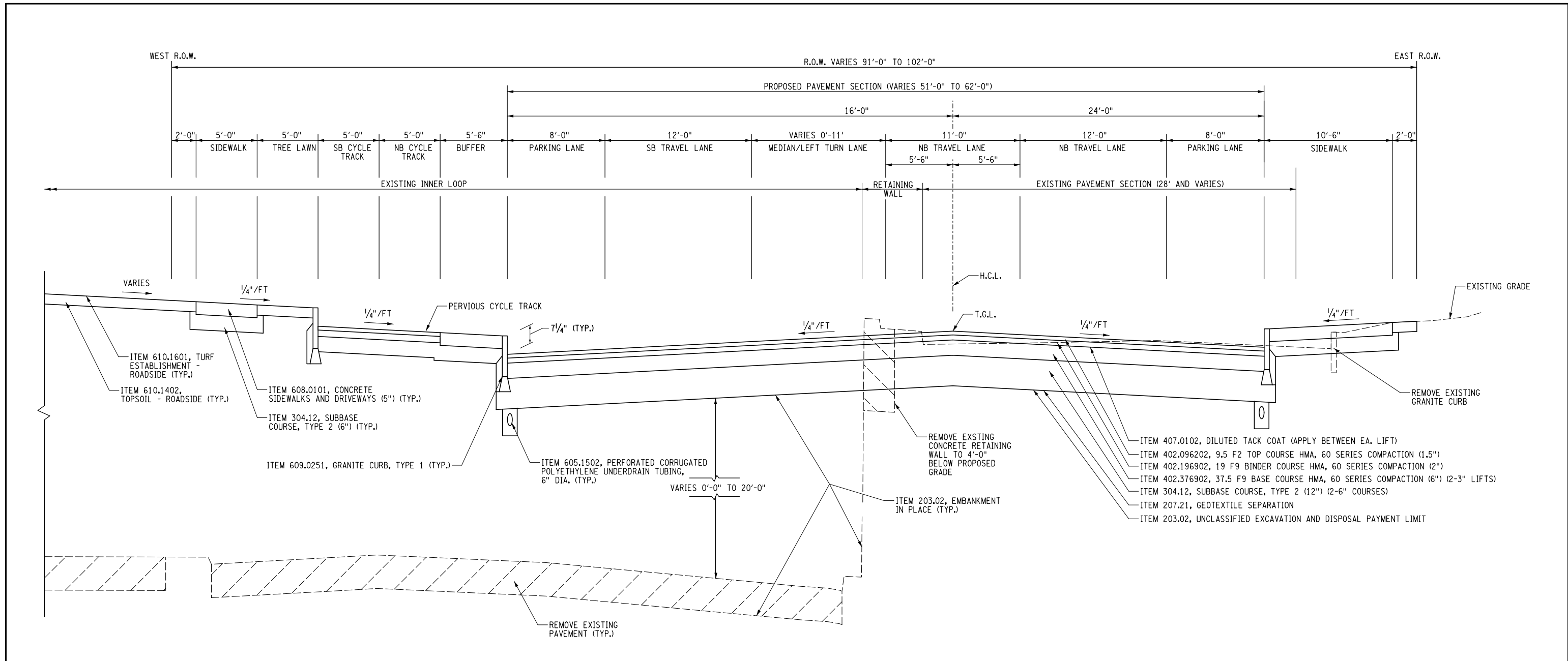

TYPICAL SECTION
 SOUTH UNION STREET - 4 LANE ROAD WITH CYCLE TRACK
 (STA. USS 28+00 TO STA. USS 31+89)

Design File: \\s020285\Technical\Drawings\Plan Set\13.13.02.dgn
 Date/Time: 3/27/2014 9:48:12 AM
 Plotted By: cdbark

IT IS A VIOLATION OF LAW FOR ANY PERSON, UNLESS THEY ARE ACTING UNDER THE DIRECTION OF A LICENSED PROFESSIONAL ENGINEER, ARCHITECT, LANDSCAPE ARCHITECT, OR LAND SURVEYOR, TO ALTER AN ITEM IN ANY WAY. IF AN ITEM BEARING THE STAMP OF A LICENSED PROFESSIONAL IS ALTERED, THE ALTERING ENGINEER, ARCHITECT, LANDSCAPE ARCHITECT, OR LAND SURVEYOR SHALL STAMP THE DOCUMENT AND INCLUDE THE NOTATION "ALTERED BY" FOLLOWED BY THEIR SIGNATURE, THE DATE OF SUCH ALTERATION, AND A SPECIFIC DESCRIPTION OF THE ALTERATION.			
Permit-Seal	Consultants	Revision	Issued
		By	By
		Appd.	Appd.
		YY.MM.DD	YY.MM.DD



The Contractor shall verify and be responsible for all dimensions. DO NOT scale the drawing - any errors or omissions shall be reported to Stantec without delay.

The Copyrights to all designs and drawings are the property of Stantec. Reproduction or use for any purpose other than that authorized by Stantec is forbidden.

Client/Project
 CITY OF ROCHESTER
 INNER LOOP EAST TRANSFORMATION PROJECT
 S. CLINTON AVENUE TO EAST MAIN STREET
 P.I.N. 4940.T7 D017599
 ROCHESTER, NEW YORK

File Name: _____
 Dwn. Chkd. Dsgn. 14.03
 YY.MM.DD

Title
 TYPICAL SECTION
 UNION STREET

Project No. 192500295
 Scale N.T.S.
 Drawing No. TS-2
 Sheet XXX of XXX
 Revision 0

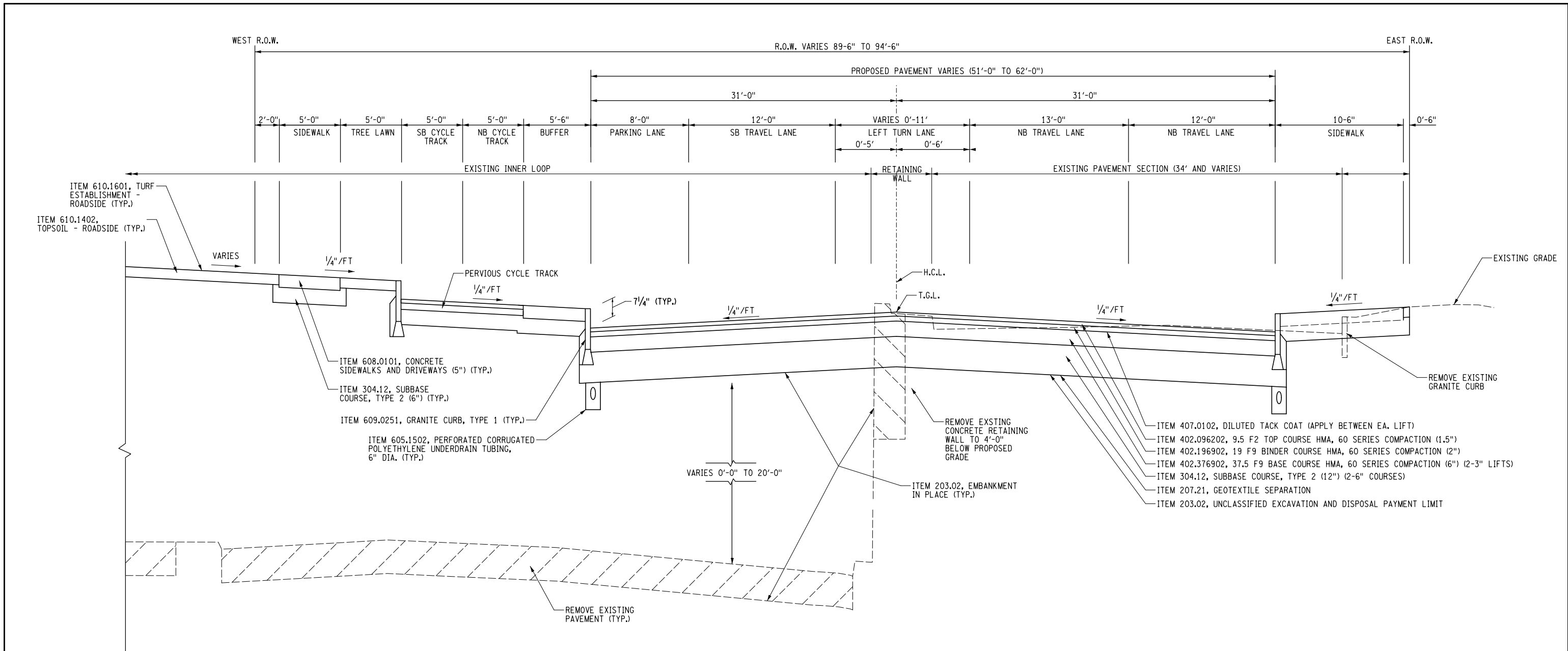

TYPICAL SECTION
NORTH UNION STREET - 4 LANE ROAD WITH CYCLE TRACK
 (STA. USN 10+00 TO STA. USN 12+50)

Design File: I:\192500295\Task\Station\Drawings\Plan Set\13_13-03.dgn
 Date/Time: 3/27/2014 9:48:12 AM
 Plotted By: ddbark

Revision	By	Appd.	YY.MM.DD	Issued	By	Appd.	YY.MM.DD

Permit-Seal	Consultants

Stantec

61 Commercial St. Suite 100
 Rochester, NY 14614
 www.stantec.com

The Contractor shall verify and be responsible for all dimensions. DO NOT scale the drawing - any errors or omissions shall be reported to Stantec without delay.

The Copyrights to all designs and drawings are the property of Stantec. Reproduction or use for any purpose other than that authorized by Stantec is forbidden.

Client/Project
 CITY OF ROCHESTER
 INNER LOOP EAST TRANSFORMATION PROJECT
 S. CLINTON AVENUE TO EAST MAIN STREET
 P.I.N. 4940.T7 D017599
 ROCHESTER, NEW YORK

File Name: _____ Dwn. Chkd. Dsgn. _____ 14.03 YY.MM.DD

Title
 TYPICAL SECTION
 HOWELL STREET

Project No. 192500295 Scale N.T.S.

Drawing No. TS-3 Sheet XXX of XXX Revision 0

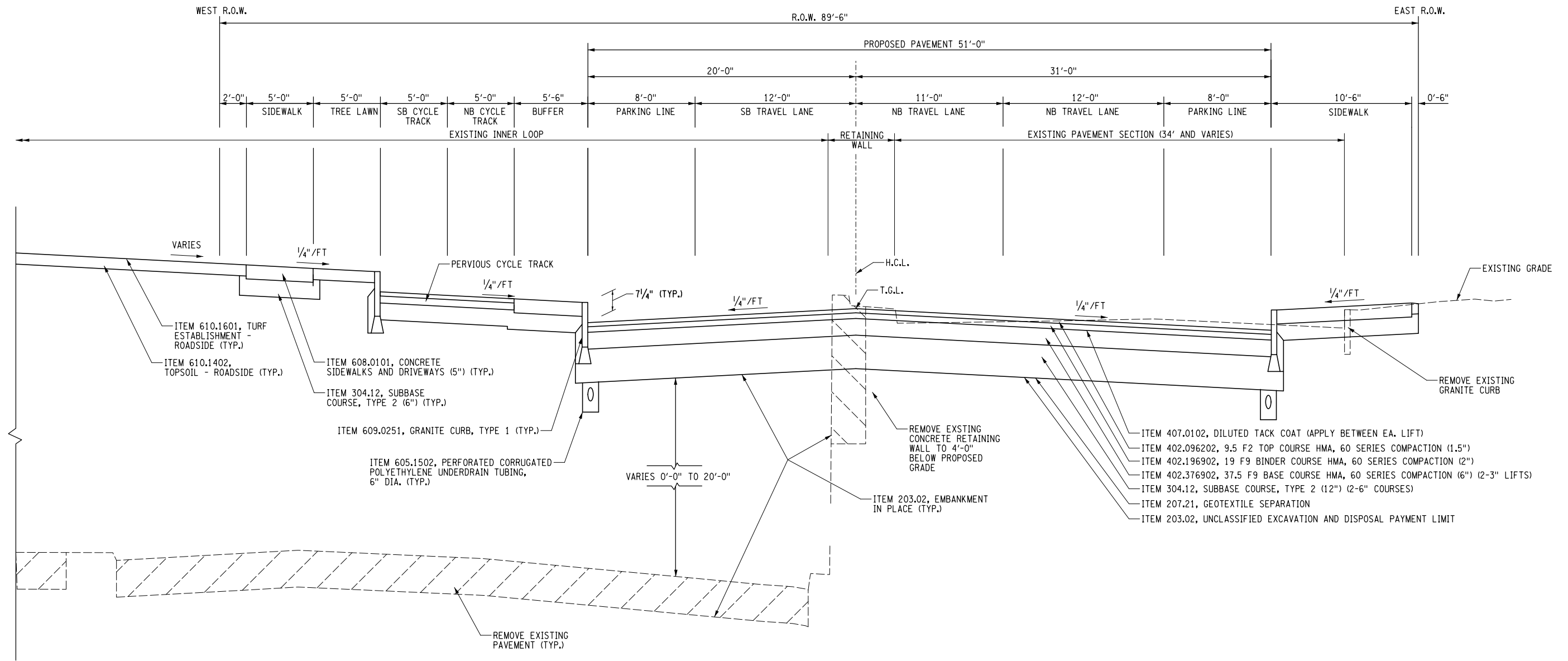

TYPICAL SECTION
 NORTH UNION STREET - 4 LANE ROAD WITH CYCLE TRACK
 (STA. USN 12+50 TO STA. USN 22+50)

Design File: U:\192500295\Transportation\Drawings\Plan Set\13\13-04.dgn
 Date/Time: 3/27/2014 9:48:13 AM
 Plotted By: ddbark

IT IS A VIOLATION OF LAW FOR ANY PERSON, UNLESS THEY ARE ACTING UNDER THE DIRECTION OF A LICENSED PROFESSIONAL ENGINEER, ARCHITECT, LANDSCAPE ARCHITECT, OR LAND SURVEYOR, TO ALTER AN ITEM IN ANY WAY. IF AN ITEM BEARING THE STAMP OF A LICENSED PROFESSIONAL IS ALTERED, THE ALTERING ENGINEER, ARCHITECT, LANDSCAPE ARCHITECT, OR LAND SURVEYOR SHALL STAMP THE DOCUMENT AND INCLUDE THE NOTATION "ALTERED BY" FOLLOWED BY THEIR SIGNATURE, THE DATE OF SUCH ALTERATION, AND A SPECIFIC DESCRIPTION OF THE ALTERATION.				Permit-Seal	Consultants		
Revision	By	Appd.	YY.MM.DD	Issued	By	Appd.	YY.MM.DD

61 Commercial St, Suite 100
 Rochester, NY 14614
 www.stantec.com

The Contractor shall verify and be responsible for all dimensions. DO NOT scale the drawing - any errors or omissions shall be reported to Stantec without delay.

The Copyrights to all designs and drawings are the property of Stantec. Reproduction or use for any purpose other than that authorized by Stantec is forbidden.

Client/Project	CITY OF ROCHESTER		
	INNER LOOP EAST TRANSFORMATION PROJECT S. CLINTON AVENUE TO EAST MAIN STREET P.I.N. 4940.T7 D017599		
	ROCHESTER, NEW YORK		
File Name:			14.03 YY.MM.DD
Dwn.	Chkd.	Dsgn.	

Title	TYPICAL SECTION		
Project No.	Scale		
192500295	N.T.S.		
Drawing No.	Sheet	Revision	
TS-4	XXX of XXX	0	

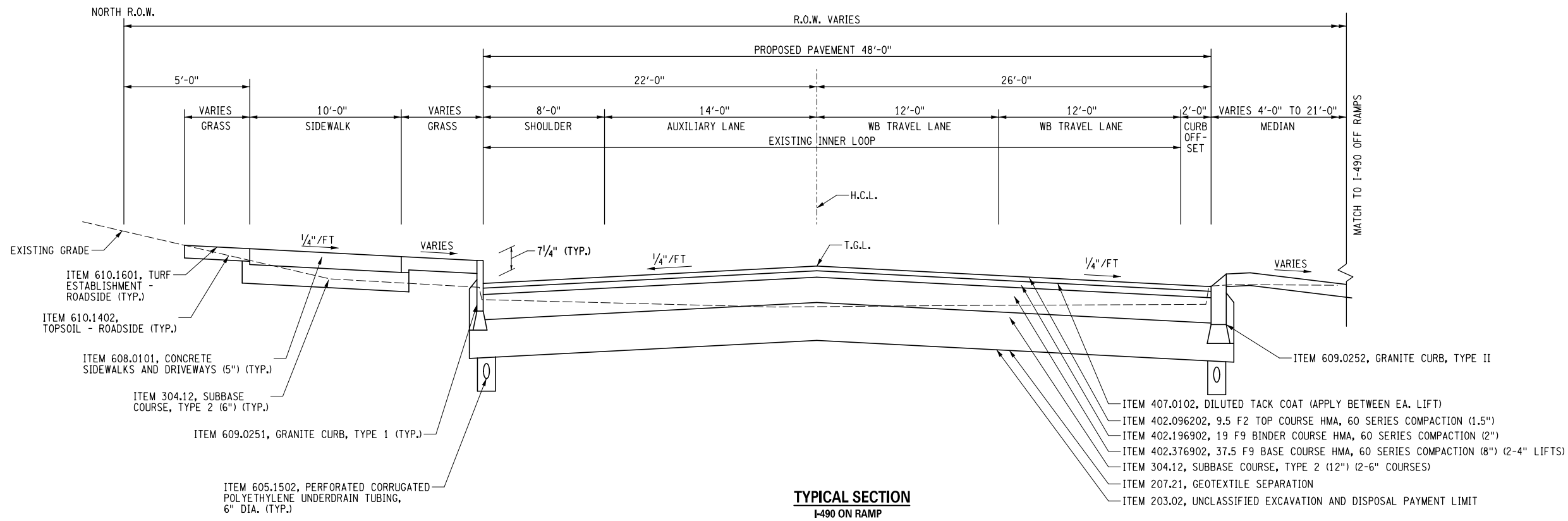

TYPICAL SECTION
I-490 ON RAMP
(STA. WB 13+31 TO STA. WB 17+50)

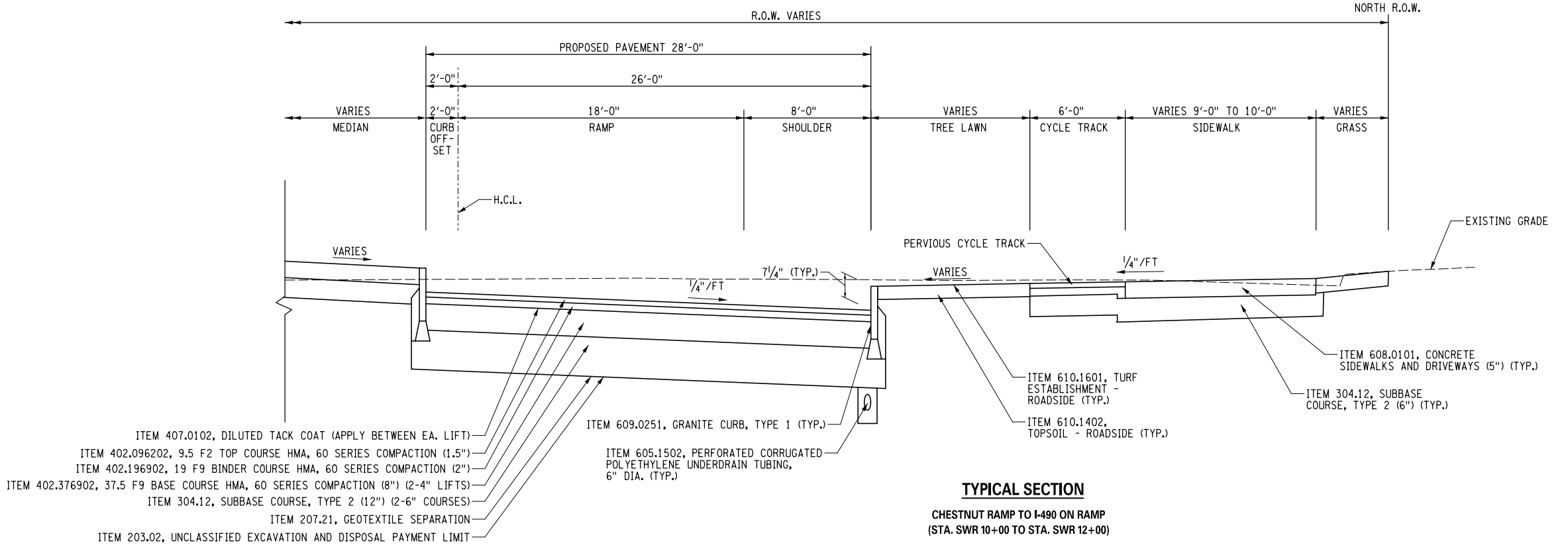

TYPICAL SECTION
CHESTNUT RAMP TO I-490 ON RAMP
(STA. SWR 10+00 TO STA. SWR 12+00)

Design File: U:\192500295\Transportation\Drawings\Plan Set\13\13-05.dgn
 Date/Time: 3/27/2014 9:48:14 AM
 Plotted By: cdbark

IT IS A VIOLATION OF LAW FOR ANY PERSON, UNLESS THEY ARE ACTING UNDER THE DIRECTION OF A LICENSED PROFESSIONAL ENGINEER, ARCHITECT, LANDSCAPE ARCHITECT, OR LAND SURVEYOR, TO ALTER AN ITEM IN ANY WAY. IF AN ITEM BEARING THE STAMP OF A LICENSED PROFESSIONAL IS ALTERED, THE ALTERING ENGINEER, ARCHITECT, LANDSCAPE ARCHITECT, OR LAND SURVEYOR SHALL STAMP THE DOCUMENT AND INCLUDE THE NOTATION "ALTERED BY" FOLLOWED BY THEIR SIGNATURE, THE DATE OF SUCH ALTERATION, AND A SPECIFIC DESCRIPTION OF THE ALTERATION.		Permit-Seal	Consultants
Revision	By	Appd.	YY.MM.DD
Issued	By	Appd.	YY.MM.DD



The Contractor shall verify and be responsible for all dimensions. DO NOT scale the drawing - any errors or omissions shall be reported to Stantec without delay.

The Copyrights to all designs and drawings are the property of Stantec. Reproduction or use for any purpose other than that authorized by Stantec is forbidden.

Client/Project
CITY OF ROCHESTER
INNER LOOP EAST TRANSFORMATION PROJECT
S. CLINTON AVENUE TO EAST MAIN STREET
P.I.N. 4940.T7 D017599
ROCHESTER, NEW YORK

File Name: _____
Dwn. Chkd. Dsgn. 14.03
YY.MM.DD

Title		
TYPICAL SECTION		
Project No.	Scale	
192500295	N.T.S.	
Drawing No.	Sheet	Revision
TS-5	XXX of XXX	0

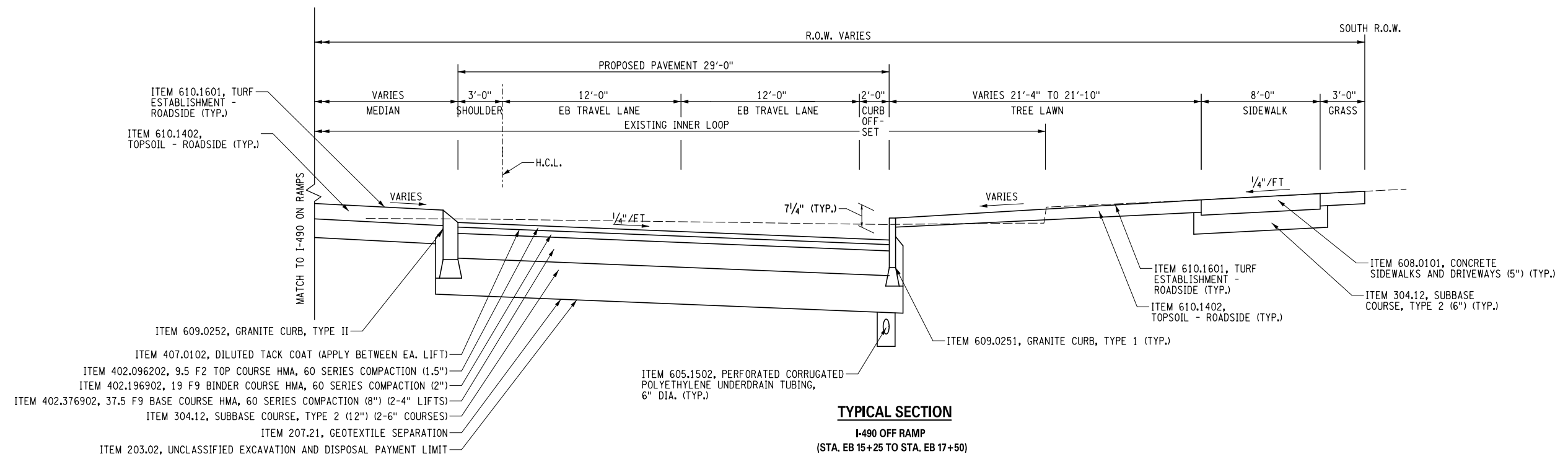
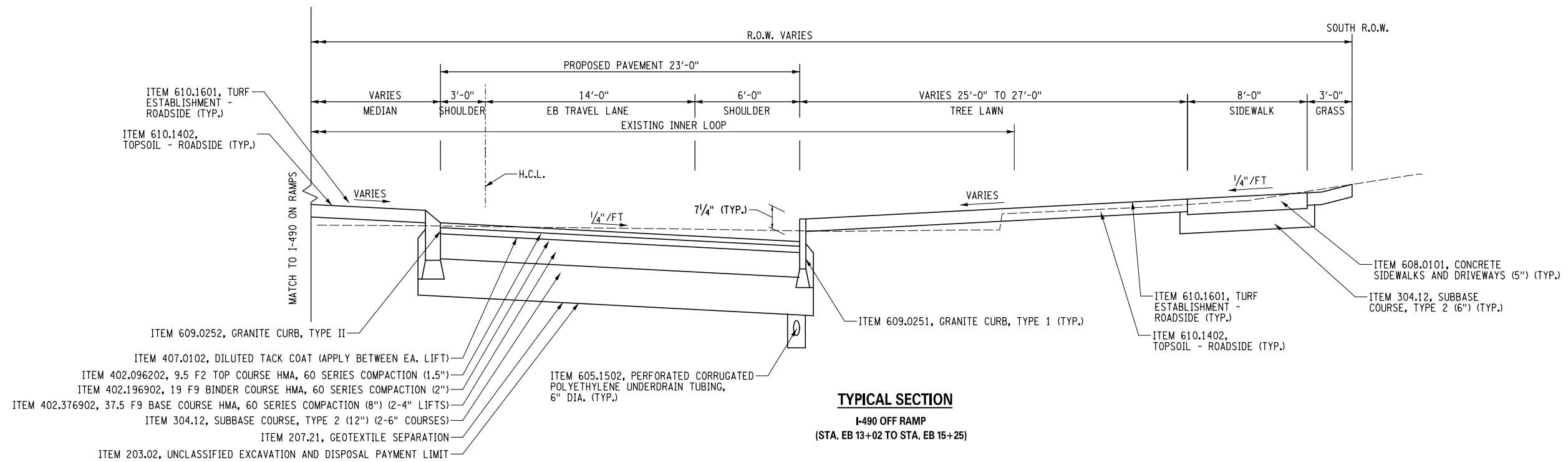

IT IS A VIOLATION OF LAW FOR ANY PERSON, UNLESS THEY ARE ACTING UNDER THE DIRECTION OF A LICENSED PROFESSIONAL ENGINEER, ARCHITECT, LANDSCAPE ARCHITECT, OR LAND SURVEYOR, TO ALTER AN ITEM IN ANY WAY. IF AN ITEM BEARING THE STAMP OF A LICENSED PROFESSIONAL IS ALTERED, THE ALTERING ENGINEER, ARCHITECT, LANDSCAPE ARCHITECT, OR LAND SURVEYOR SHALL STAMP THE DOCUMENT AND INCLUDE THE NOTATION "ALTERED BY" FOLLOWED BY THEIR SIGNATURE, THE DATE OF SUCH ALTERATION, AND A SPECIFIC DESCRIPTION OF THE ALTERATION.

Permit-Seal

Consultants



Client/Project
CITY OF ROCHESTER
INNER LOOP EAST TRANSFORMATION PROJECT
S. CLINTON AVENUE TO EAST MAIN STREET
P.I.N. 4940.T7 D017599
ROCHESTER, NEW YORK

Title
TYPICAL SECTION

Project No. 192500295 Scale N.T.S.
Drawing No. TS-6 Sheet XXX of XXX Revision 0

Revision	By	Appd.	YY.MM.DD	Issued	By	Appd.	YY.MM.DD

The Contractor shall verify and be responsible for all dimensions. DO NOT scale the drawing - any errors or omissions shall be reported to Stantec without delay.
The Copyrights to all designs and drawings are the property of Stantec. Reproduction or use for any purpose other than that authorized by Stantec is forbidden.

File Name: 14.03 YY.MM.DD
Dwn. Chkd. Dsgn.

Design File: U:\192500295\Transportation\Preparation\Drawings\Plan Set\13\13-06.dgn
 Date Plotted: 3/27/2014 9:48:15 AM
 Plotted By: cdbark

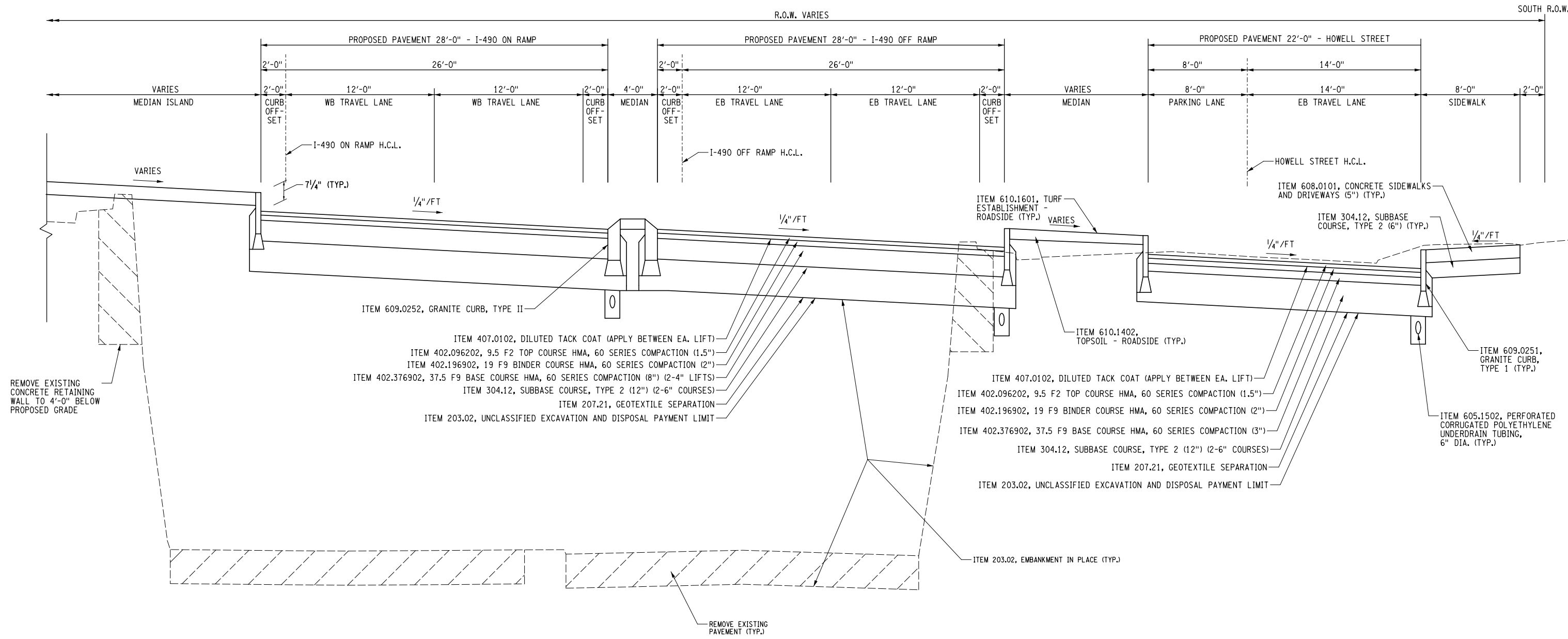

TYPICAL SECTION
I-490 ON RAMP AND OFF RAMP AND HOWELL STREET
 (STA. WB & EB 17+50 TO STA. WB & EB 20+00)

IT IS A VIOLATION OF LAW FOR ANY PERSON, UNLESS THEY ARE ACTING UNDER THE DIRECTION OF A LICENSED PROFESSIONAL ENGINEER, ARCHITECT, LANDSCAPE ARCHITECT, OR LAND SURVEYOR, TO ALTER AN ITEM IN ANY WAY. IF AN ITEM BEARING THE STAMP OF A LICENSED PROFESSIONAL IS ALTERED, THE ALTERING ENGINEER, ARCHITECT, LANDSCAPE ARCHITECT, OR LAND SURVEYOR SHALL STAMP THE DOCUMENT AND INCLUDE THE NOTATION "ALTERED BY" FOLLOWED BY THEIR SIGNATURE, THE DATE OF SUCH ALTERATION, AND A SPECIFIC DESCRIPTION OF THE ALTERATION.			
Revision	By	Appd.	YY.MM.DD

Permit-Seal

Consultants



61 Commercial St, Suite 100
 Rochester, NY 14614
 www.stantec.com

The Contractor shall verify and be responsible for all dimensions. DO NOT scale the drawing - any errors or omissions shall be reported to Stantec without delay.

The Copyrights to all designs and drawings are the property of Stantec. Reproduction or use for any purpose other than that authorized by Stantec is forbidden.

Client/Project	CITY OF ROCHESTER		
	INNER LOOP EAST TRANSFORMATION PROJECT S. CLINTON AVENUE TO EAST MAIN STREET P.I.N. 4940.T7 D017599		
	ROCHESTER, NEW YORK		
File Name:	14.03 YY.MM.DD		
Dwn.	Chkd.	Dsgn.	

Title		TYPICAL SECTION	
Project No.	Scale	N.T.S.	
192500295			
Drawing No.	Sheet	Revision	
TS-7	XXX of XXX	0	

Design File: U:\192500295\Transportation\Preparation\Drawings\Plan Set\13-13-07.dgn
 Date Plotted: 3/27/2014 9:48:15 AM
 Plotted By: cdbark

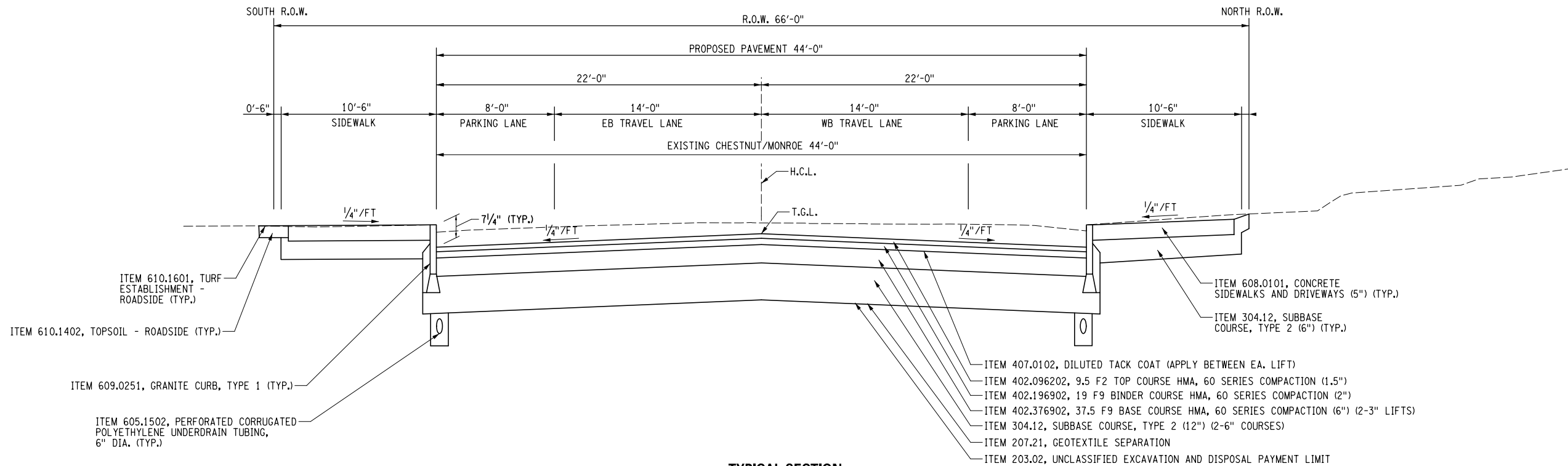

TYPICAL SECTION
MONROE AVE - 2 LANE ROAD WITH PARKING
 (STA. MA 15+00 TO STA. MA 18+00)

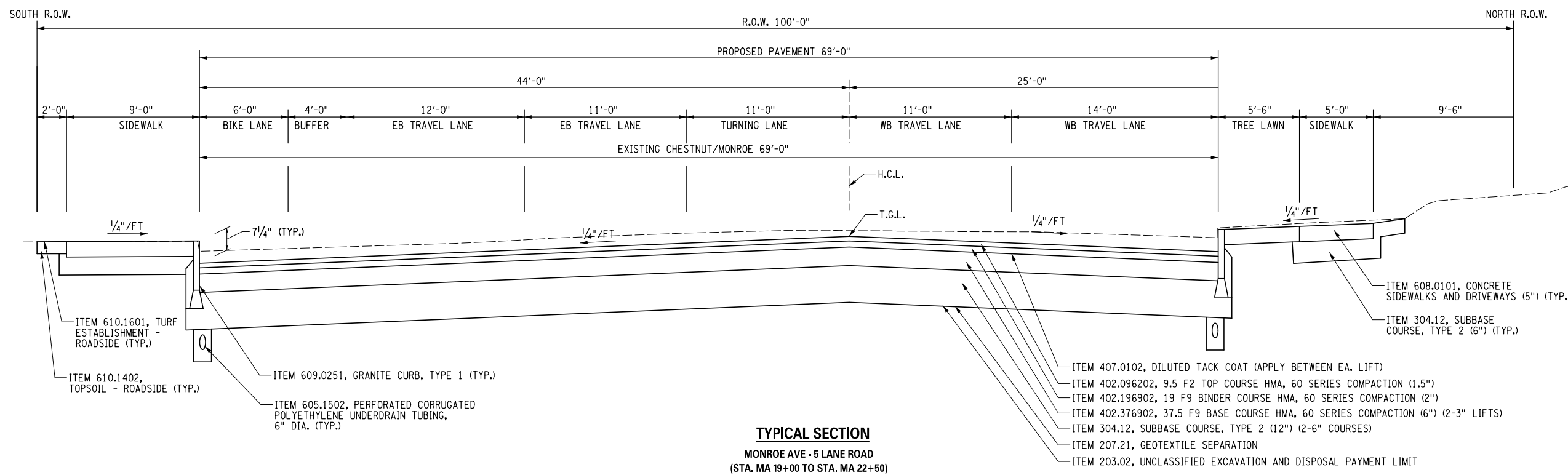

TYPICAL SECTION
MONROE AVE - 5 LANE ROAD
 (STA. MA 19+00 TO STA. MA 22+50)

Design File: U:\192500295\Transportation\Drawings\Plan Set\13\13-08.dgn
 Date/Time: 3/27/2014 9:48:16 AM
 Plotted By: gbbark

IT IS A VIOLATION OF LAW FOR ANY PERSON, UNLESS THEY ARE ACTING UNDER THE DIRECTION OF A LICENSED PROFESSIONAL ENGINEER, ARCHITECT, LANDSCAPE ARCHITECT, OR LAND SURVEYOR, TO ALTER AN ITEM IN ANY WAY. IF AN ITEM BEARING THE STAMP OF A LICENSED PROFESSIONAL IS ALTERED, THE ALTERING ENGINEER, ARCHITECT, LANDSCAPE ARCHITECT, OR LAND SURVEYOR SHALL STAMP THE DOCUMENT AND INCLUDE THE NOTATION "ALTERED BY" FOLLOWED BY THEIR SIGNATURE, THE DATE OF SUCH ALTERATION, AND A SPECIFIC DESCRIPTION OF THE ALTERATION.

Revision	By	Appd.	YY.MM.DD	Issued	By	Appd.	YY.MM.DD

Permit-Seal

Consultants

61 Commercial St. Suite 100
 Rochester, NY 14614
 www.stantec.com

The Contractor shall verify and be responsible for all dimensions. DO NOT scale the drawing - any errors or omissions shall be reported to Stantec without delay.

The Copyrights to all designs and drawings are the property of Stantec. Reproduction or use for any purpose other than that authorized by Stantec is forbidden.

Client/Project
 CITY OF ROCHESTER
 INNER LOOP EAST TRANSFORMATION PROJECT
 S. CLINTON AVENUE TO EAST MAIN STREET
 P.I.N. 4940.T7 D017599
 ROCHESTER, NEW YORK

File Name: XXX-XXX-XXX
 14.03
 YY.MM.DD
 Dwn. Chkd. Dsgn.

Title	
TYPICAL SECTION	
Project No. 192500295	Scale N.T.S.
Drawing No. TS-8	Sheet XXX of XXX
Revision 0	

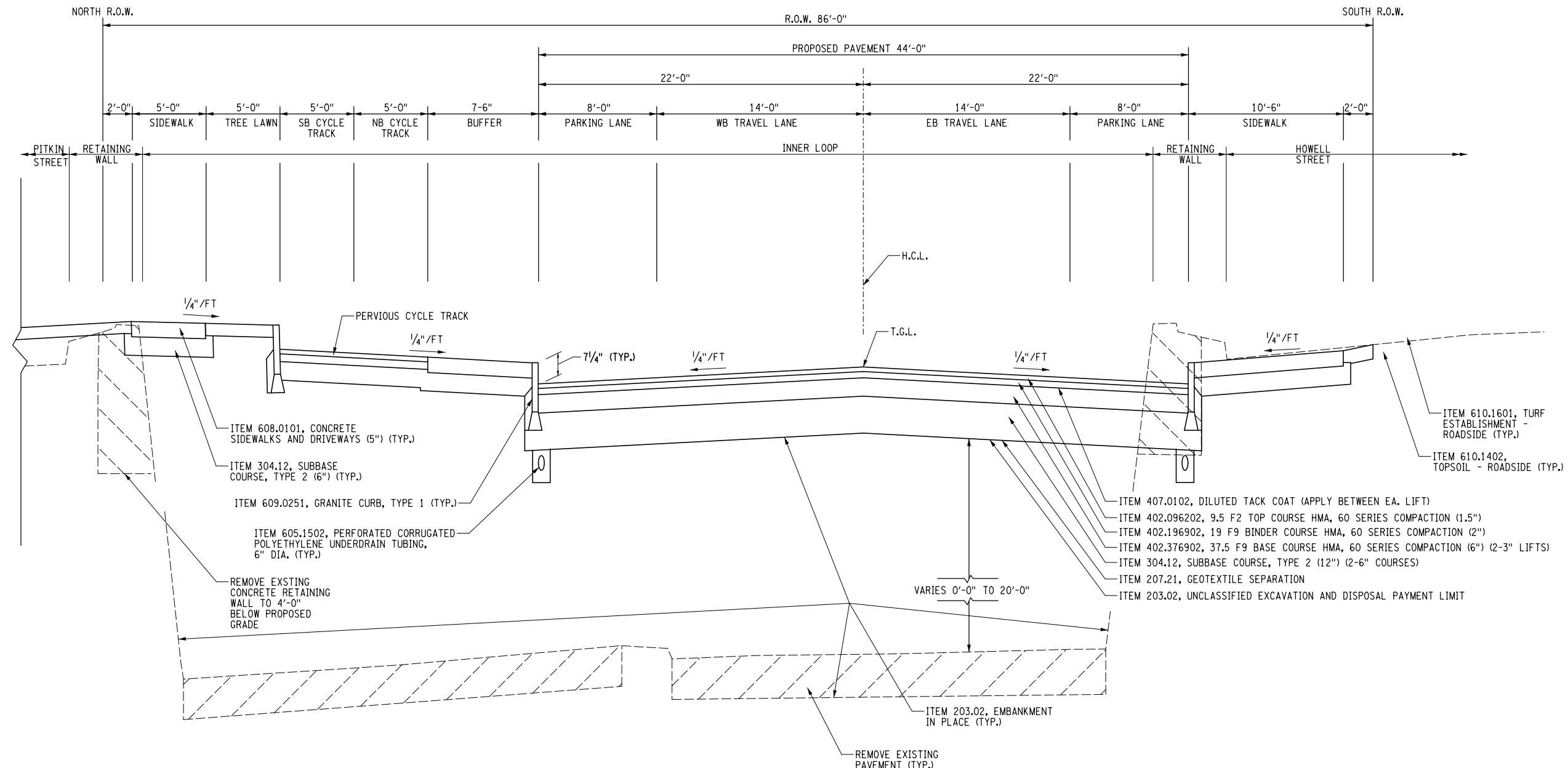

TYPICAL SECTION

HOWELL STREET - 2 LANE ROAD WITH ON STREET PARKING
(STA. HSE 13+50 TO STA. HSE 17+50)

IT IS A VIOLATION OF LAW FOR ANY PERSON, UNLESS THEY ARE ACTING UNDER THE DIRECTION OF A LICENSED PROFESSIONAL ENGINEER, ARCHITECT, LANDSCAPE ARCHITECT, OR LAND SURVEYOR, TO ALTER AN ITEM IN ANY WAY. IF AN ITEM BEARING THE STAMP OF A LICENSED PROFESSIONAL IS ALTERED, THE ALTERING ENGINEER, ARCHITECT, LANDSCAPE ARCHITECT, OR LAND SURVEYOR SHALL STAMP THE DOCUMENT AND INCLUDE THE NOTATION "ALTERED BY" FOLLOWED BY THEIR SIGNATURE, THE DATE OF SUCH ALTERATION, AND A SPECIFIC DESCRIPTION OF THE ALTERATION.

Revision	By	Appd.	YY.MM.DD	Issued	By	Appd.	YY.MM.DD

Permit-Seal

Consultants



The Contractor shall verify and be responsible for all dimensions. DO NOT scale the drawing - any errors or omissions shall be reported to Stantec without delay.

The Copyrights to all designs and drawings are the property of Stantec. Reproduction or use for any purpose other than that authorized by Stantec is forbidden.

Client/Project
CITY OF ROCHESTER

INNER LOOP EAST TRANSFORMATION PROJECT
S. CLINTON AVENUE TO EAST MAIN STREET
P.I.N. 4940.T7 D017599

ROCHESTER, NEW YORK

File Name: _____ 14.03
YY.MM.DD

Dwn. Chkd. Dsgn.

Title
TYPICAL SECTION

Project No. 192500295 Scale N.T.S.

Drawing No. TS-10 Sheet XXX of XXX Revision 0

Desktop File: U:\192500295\Transportation\Preliminary Drawings\Plan Set\13\13-10.dgn
 Date Plotted: 3/27/2014 9:48:17 AM
 Plotted By: ddbark

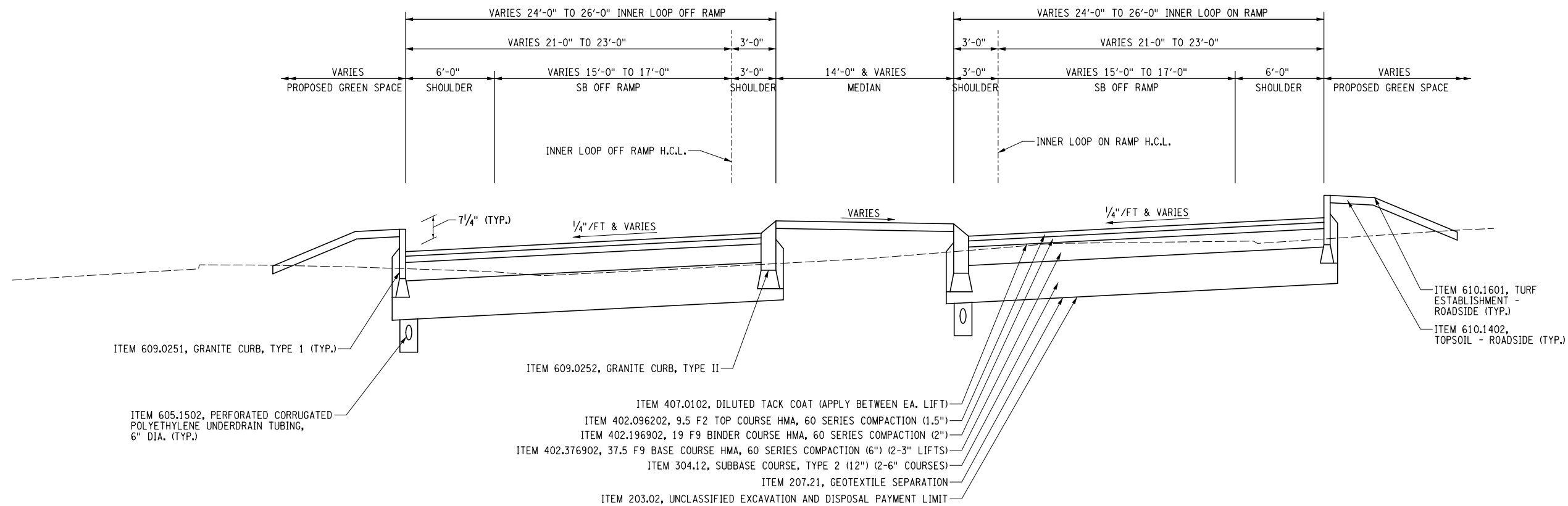

TYPICAL SECTION
INNER LOOP ON-RAMP AND OFF-RAMP
 (STA. SB 10+00 TO STA. SB 17+00)
 (STA. NB 10+00 TO STA. NB 16+35)

Design File: U:\192500295\Technical\Drawings\Plan Set\13-11.dgn
 Date/Time: 3/27/2014 9:48:18 AM
 Plotted By: cdbark

IT IS A VIOLATION OF LAW FOR ANY PERSON, UNLESS THEY ARE ACTING UNDER THE DIRECTION OF A LICENSED PROFESSIONAL ENGINEER, ARCHITECT, LANDSCAPE ARCHITECT, OR LAND SURVEYOR, TO ALTER AN ITEM IN ANY WAY. IF AN ITEM BEARING THE STAMP OF A LICENSED PROFESSIONAL IS ALTERED, THE ALTERING ENGINEER, ARCHITECT, LANDSCAPE ARCHITECT, OR LAND SURVEYOR SHALL STAMP THE DOCUMENT AND INCLUDE THE NOTATION "ALTERED BY" FOLLOWED BY THEIR SIGNATURE, THE DATE OF SUCH ALTERATION, AND A SPECIFIC DESCRIPTION OF THE ALTERATION.				Permit-Seal	Consultants		
Revision	By	Appd.	YY.MM.DD	Issued	By	Appd.	YY.MM.DD

61 Commercial St., Suite 100
 Rochester, NY 14614
 www.stantec.com

Client/Project
 CITY OF ROCHESTER
 INNER LOOP EAST TRANSFORMATION PROJECT
 S. CLINTON AVENUE TO EAST MAIN STREET
 P.I.N. 4940.T7 D017599
 ROCHESTER, NEW YORK

Title		TYPICAL SECTION	
Project No.	Scale	192500295	N.T.S.
Drawing No.	Sheet	TS-11	XXX of XXX
Revision		0	

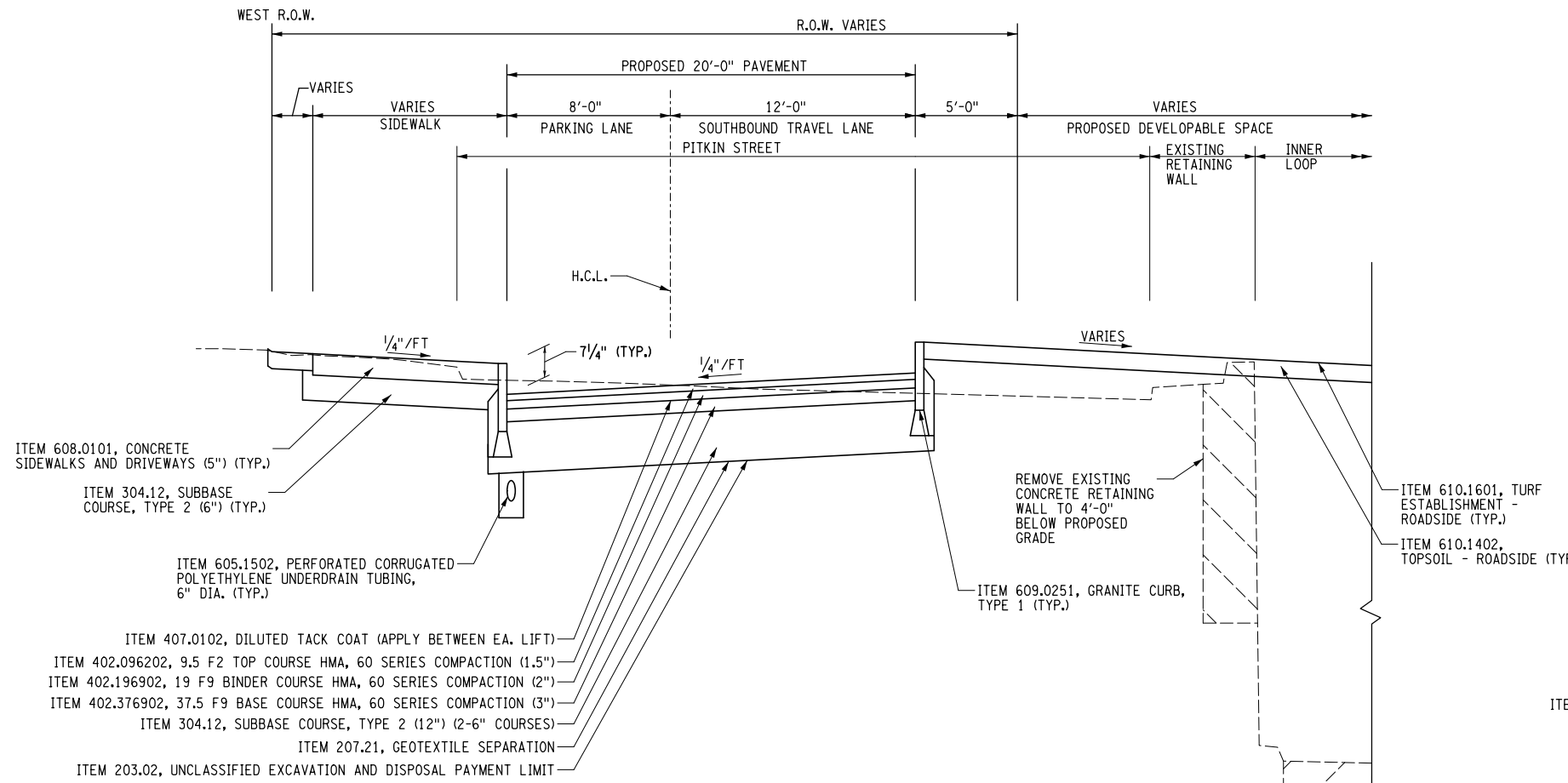

TYPICAL SECTION
PITKIN STREET
(STA. PS 10+00 TO STA. PS 16+50)

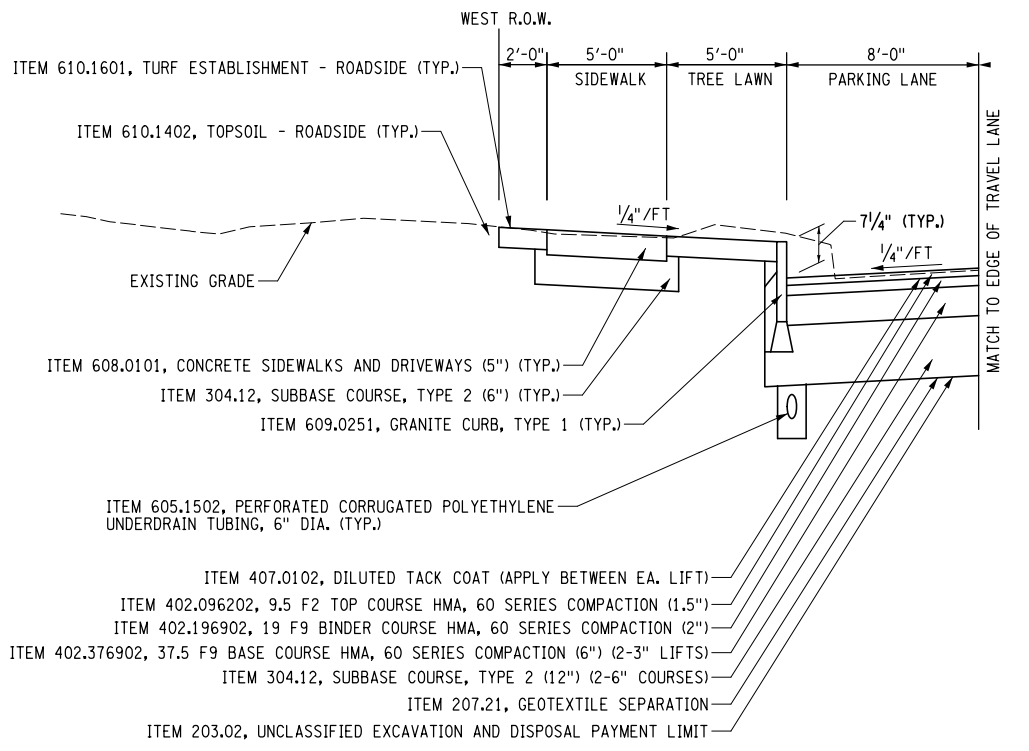

TYPICAL SECTION - RECESSED PARKING
UNION STREET - 2 LANE ROAD WITH BICYCLE LANES
(STA. USS 10+50 TO STA. USS 15+50)

IT IS A VIOLATION OF LAW FOR ANY PERSON, UNLESS THEY ARE ACTING UNDER THE DIRECTION OF A LICENSED PROFESSIONAL ENGINEER, ARCHITECT, LANDSCAPE ARCHITECT, OR LAND SURVEYOR, TO ALTER AN ITEM IN ANY WAY. IF AN ITEM BEARING THE STAMP OF A LICENSED PROFESSIONAL IS ALTERED, THE ALTERING ENGINEER, ARCHITECT, LANDSCAPE ARCHITECT, OR LAND SURVEYOR SHALL STAMP THE DOCUMENT AND INCLUDE THE NOTATION "ALTERED BY" FOLLOWED BY THEIR SIGNATURE, THE DATE OF SUCH ALTERATION, AND A SPECIFIC DESCRIPTION OF THE ALTERATION.

Permit-Seal

Consultants



Client/Project
CITY OF ROCHESTER
INNER LOOP EAST TRANSFORMATION PROJECT
S. CLINTON AVENUE TO EAST MAIN STREET
P.I.N. 4940.T7 D017599
ROCHESTER, NEW YORK

Title
TYPICAL SECTION

Project No. 192500295 Scale N.T.S.

Drawing No. TS-12 Sheet XXX of XXX Revision 0

Revision	By	Appd.	YY.MM.DD	Issued	By	Appd.	YY.MM.DD

By	Appd.	YY.MM.DD	By	Appd.	YY.MM.DD

The Contractor shall verify and be responsible for all dimensions. DO NOT scale the drawing - any errors or omissions shall be reported to Stantec without delay.

The Copyrights to all designs and drawings are the property of Stantec. Reproduction or use for any purpose other than that authorized by Stantec is forbidden.

File Name: _____ 14.03
Dwn. Chkd. Dsgn. YY.MM.DD

Design File: U:\192500295\Transportation\Preparation\Drawings\Plan Set\13\13-12.dgn
 Date/Time: 3/27/2014 9:48:19 AM
 Plotted By: cdbark

APPENDIX B

Project Costs

**PROJECT: Inner Loop East Reconstruction Project
Alternative 1- Construction Costs
PIN 4940.T7**

JANUARY 2013

ITEM #	DESCRIPTION	QUANTITY	PAY UNIT	UNIT PRICE	AMOUNT
203.02	UNCLASSIFIED EXCAVATION AND DISPOSAL	40000	CY	\$18.00	\$720,000.00
203.03	EMBANKMENT IN PLACE	120000	CY	\$20.00	\$2,400,000.00
203.07	SELECT GRANULAR BACKFILL	3150	CY	\$45.00	\$141,750.00
204.01	CONTROLLED LOW STRENGTH MATERIAL (CLSM)	615	CY	\$125.00	\$76,875.00
206.02	TRENCH AND CULVERT EXCAVATION	2100	CY	\$20.00	\$42,000.00
206.03	CONDUIT EXCAVATION AND BACKFILL INCL. RESTORATION	17995	LF	\$10.00	\$179,950.00
206.04	TRENCH AND CULVERT EXCAVATION - O.G.	5125	CY	\$20.00	\$102,500.00
206.XX	TRENCH AND CULVERT ROCK EXCAVATION	2130	CY	\$200.00	\$426,000.00
207.21	GEOTEXTILE SEPARATION	42320	SY	\$2.00	\$84,640.00
304.12	SUBBASE COURSE, TYPE 2	17938	CY	\$40.00	\$717,520.00
402.098202	9.5 F2 TOP COURSE HMA, 80 SERIES COMPACTION	4181	TON	\$110.00	\$459,910.00
402.098212	PLANT PRODUCTION QUALITY ADJUSTMENT TO 402.098202	209	QU	\$70.00	\$14,633.50
402.198902	19 F9 BINDER COURSE HMA, 80 SERIES COMPACTION	4950	TON	\$105.00	\$519,750.00
402.198912	PLANT PRODUCTION QUALITY ADJUSTMENT TO 402.198902	248	QU	\$70.00	\$17,325.00
402.378902	37.5 F9 BASE COURSE HMA, 80 SERIES COMPACTION	14850	TON	\$100.00	\$1,485,000.00
402.378912	PLANT PRODUCTION QUALITY ADJUSTMENT TO 402.378902	743	QU	\$70.00	\$51,975.00
407.0102	DILUTED TACK COAT	8540	GAL	\$7.00	\$59,780.00
490.30	MISC. COLD MILLING	3200	SY	\$10.00	\$32,000.00
520.50140008	SAW CUTTING, ASPHALT PAVEMENT, ASPHALT SURFACE COURSE, CONCRETE PAVEMENT OR ASPHALT OVERLAY ON CONCRETE PAVEMENT	900	LF	\$6.00	\$5,400.00
500.XX	STRUCTURE REMOVAL - EAST AVENUE BRIDGE	1	LS	\$326,000.00	\$326,000.00
500.XX	STRUCTURE REMOVAL - BROAD STREET BRIDGE	1	LS	\$423,000.00	\$423,000.00
500.XX	STRUCTURE REMOVAL - MONROE AVENUE BRIDGE	1	LS	\$297,000.00	\$297,000.00
580.01	REMOVAL OF STRUCTURAL CONCRETE	1650	CY	\$800.00	\$1,320,000.00
587.02	BRIDGE RAILING REMOVAL AND STORAGE	8800	LF	\$40.00	\$352,000.00
603.6211	REINFORCED CONCRETE PIPE CLASS V, 48 INCH DIAMETER	1200	LF	\$450.00	\$540,000.00
603.6212	REINFORCED CONCRETE PIPE CLASS V, 54 INCH DIAMETER	537	LF	\$500.00	\$268,500.00
603.98100804	POLYVINYL CHLORIDE (PVC) SEWER PIPE & FITTINGS 8" DIAMETER	3500	LF	\$40.00	\$140,000.00
603.98101204	POLYVINYL CHLORIDE (PVC) SEWER PIPE & FITTINGS 12" DIAMETER	170	LF	\$80.00	\$13,600.00
603.98101804	POLYVINYL CHLORIDE (PVC) SEWER PIPE & FITTINGS 18" DIAMETER	560	LF	\$100.00	\$56,000.00

**PROJECT: Inner Loop East Reconstruction Project
Alternative 1- Construction Costs
PIN 4940.T7**

JANUARY 2013

ITEM #	DESCRIPTION	QUANTITY	PAY UNIT	UNIT PRICE	AMOUNT
603.98102404	POLYVINYL CHLORIDE (PVC) SEWER PIPE & FITTINGS 24" DIAMETER	206	LF	\$200.00	\$41,200.00
604.40720006	PRECAST SANITARY SEWER MANHOME (72 INCH DIAM.)	50	LF	\$1,000.00	\$50,000.00
604.070402	ALTERING DRAINAGE STRUCTURES, LEACHING BASINS AND MANHOLES	60	EA	\$700.00	\$42,000.00
604.500401	SPECIAL DRAINAGE STRUCTURE	700	LF	\$250.00	\$175,000.00
604.500402	SPECIAL DRAINAGE STRUCTURE (JUNCTION CHAMBER)	115	LF	\$1,200.00	\$138,000.00
605.0901	UNDERDRAIN FILTER TYPE 1	2100	CY	\$35.00	\$73,500.00
605.1502	PERFORATED CORRUGATED POLYETHYLENE UNDERDRAIN TUBING, 6 INCH DIAMETER	25000	LF	\$7.50	\$187,500.00
606.73	REMOVING AND DISPOING OF BOX BEAM GUIDERAIL	8800	LF	\$3.50	\$30,800.00
608.0101	CONCRETE SIDEWALKS AND DRIVEWAYS	2030	CY	\$380.00	\$771,400.00
608.XXXXX	COLORED AND IMPRINTED ASPHALT (CYCLE TRACK)	820	TON	\$180.00	\$147,600.00
608.020102	HOT MIX ASPHALT (HMA) SIDEWALKS, DRIVEWAYS AND BICYCLE PATHS, AND VEGETATION CONTROL STRIPS	200	TON	\$150.00	\$30,000.00
608.21	EMBEDDED DETECTABLE WARNING UNITS	110	SY	\$300.00	\$33,000.00
609.0251	GRANITE CURB (AS DETAILED) - TYPE I	24220	LF	\$30.00	\$726,600.00
610.1101	MULCH FOR PLANTING TYPE A, B & D - WOOD CHIPS AND SHREDDED BARK	225	CY	\$50.00	\$11,250.00
610.1403	TOPSOIL - LAWNS	5876	CY	\$45.00	\$264,420.00
610.1602	TURF ESTABLISHMENT - LAWNS	52900	SY	\$1.50	\$79,350.00
611.0151	PLANTING - MINOR DECIDUOUS TREES - 2 INCH CALIPER BALL & BURLAP, FIELD POTTED OR FIELD BOXE	360	EA	\$350.00	\$126,000.00
615.XXXXXXX	MISC. LANDSCAPING APPURTENANCES	1	LS	\$200,000.00	\$200,000.00
644.XXXXXXX	OVERHEAD SIGN STRUCTURE (INCLUDES PANELS)	1	EA	\$200,000.00	\$200,000.00
645.5102	GROUND-MOUNTED SIGN PANELS LESS THAN OR EQUAL TO 30 SF WITH Z-BARS	1000	SF	\$25.00	\$25,000.00
645.81	TYPE A SIGN POSTS	100	EA	\$100.00	\$10,000.00
645.85	POLE MOUNTED SIGN SUPPORT SYSTEM (BAND MOUNTED)	150	EA	\$100.00	\$15,000.00
647.61	REMOVAL OF SIGNS - SIZE A (0 - 10 SQUARE FEET)REM AND DISPOSE GROUND MOUNTED TYPE A SIGN SUPPORT(S), FDNS AND ANY ATTACHED SIGNS - SIZE I (UNDER 30 SQUARE FEET)	300	EA	\$25.00	\$7,500.00
655.1103	WELDED FRAME AND RETICULINE GRATE 3	140	EA	\$550.00	\$77,000.00
655.1202	MANHOLE FRAME AND COVER	60	EA	\$750.00	\$45,000.00
663.0112	DUCTILE IRON CEMENT LINED WATER PIPE, 12"	575	LF	\$160.00	\$92,000.00
663.0124	DUCTILE IRON CEMENT LINED WATER PIPE, 24"	300	LF	\$320.00	\$96,000.00
663.0408	PLASTIC WATER PIPE, 8"	2640	LF	\$140.00	\$369,600.00

**PROJECT: Inner Loop East Reconstruction Project
Alternative 1- Construction Costs
PIN 4940.T7**

JANUARY 2013

ITEM #	DESCRIPTION	QUANTITY	PAY UNIT	UNIT PRICE	AMOUNT
663.0412	PLASTIC WATER PIPE, 12"	750	LF	\$160.00	\$120,000.00
663.1008	RESILIENT WEDGE VALVE & VALVE BOX, 8"	12	EA	\$1,500.00	\$18,000.00
663.1012	RESILIENT WEDGE VALVE & VALVE BOX, 12"	2	EA	\$2,000.00	\$4,000.00
663.1124	BUTTERFLY VALVE & VALVE BOX, 24"	1	EA	\$20,000.00	\$20,000.00
663.1136	BUTTERFLY VALVE & VALVE BOX, 36"	2	EA	\$30,000.00	\$60,000.00
663.13XX	HYDRANT	10	EA	\$3,000.00	\$30,000.00
663.33	ADJUST EXISTING VALVE BOX ELEVATION	100	EA	\$250.00	\$25,000.00
670.0104	FOUNDATION FOR LIGHT STANDARDS, 4 FEET LONG	100	EA	\$1,000.00	\$100,000.00
670.2602	RIGID PLASTIC CONDUIT, 2"	3000	LF	\$3.00	\$9,000.00
670.xx	NEW LIGHTPOLE AND LUMINAIRE	100	EA	\$2,000.00	\$200,000.00
670.300101MO	INSTALL LIGHTING PULLBOX FRAME AND COVER (CITY OF ROCHESTER) - 2' X 2' SQUARE	100	EA	\$125.00	\$12,500.00
670.7005	SINGLE CONDUCTOR CABLE, NUMBER 8 GAUGE	25000	LF	\$3.00	\$75,000.00
670.7501	GROUND WIRE NO. 6 AWG	12000	LF	\$2.50	\$30,000.00
670.81	REMOVE AND DISPOSE OF LAMPPPOST ASSEMBLY	295	EA	\$175.00	\$51,625.00
670.82	REMOVE LAMPPPOST FOUNDATION	295	EA	\$185.00	\$54,575.00
680.10020001	POWDER COATING TRAFFIC SIGNAL POLE - MAST ARM	17	EA	\$1,750.00	\$29,750.00
680.5001	POLE EXCAVATION AND CONCRETE FOUNDATION	86	CY	\$900.00	\$77,400.00
680.5002	CONCRETE BASE FOR CONTROLLER CABINET	5	EA	\$1,600.00	\$8,000.00
680.510301	PULLBOX-CIRCULAR, 24 INCH DIAMETER, REINFORCED CONCRETE	28	EA	\$1,100.00	\$30,800.00
680.510401	PULLBOX-CIRCULAR, 30 INCH DIAMETER, REINFORCED CONCRETE	28	EA	\$1,250.00	\$35,000.00
680.520106	CONDUIT, METAL STEEL, ZINC COATED, 2"	870	LF	\$10.50	\$9,135.00
680.520108	CONDUIT, METAL STEEL, ZINC COATED, 3"	8290	LF	\$15.00	\$124,350.00
680.520110	CONDUIT, METAL STEEL, ZINC COATED, 4"	20	LF	\$25.00	\$500.00
680.521603MO	CONDUIT, PVC SCHEDULE 80, 1" DIAMETER	670	LF	\$6.50	\$4,355.00
680.521610MO	CONDUIT, PVC SCHEDULE 80, 4" DIAMETER	20480	LF	\$8.50	\$174,080.00
680.54	INDUCTANCE LOOP INSTALLATION	6840	LF	\$9.75	\$66,690.00
680.71	SHIELDED LEAD-IN CABLE	12450	LF	\$1.75	\$21,787.50
680.72	INDUCTANCE LOOP WIRE	16580	LF	\$0.65	\$10,777.00
680.730208	SIGNAL CABLE, 2 CONDUCTORS, 08 AWG	400	LF	\$4.75	\$1,900.00
680.730714	SIGNAL CABLE 7 CONDUCTORS, 14 AWG	5330	LF	\$4.50	\$23,985.00

**PROJECT: Inner Loop East Reconstruction Project
Alternative 1- Construction Costs
PIN 4940.T7**

JANUARY 2013

ITEM #	DESCRIPTION	QUANTITY	PAY UNIT	UNIT PRICE	AMOUNT
680.730914	SIGNAL CABLE 9 CONDUCTORS, 14 AWG	3140	LF	\$5.25	\$16,485.00
680.79000001	REMOVE TRAFFIC SIGNAL EQUIPMENT	4	LS	\$10,000.00	\$40,000.00
680.802708MO	INSTALL ACTUATED 8 PHASE GROUND MOUNTED TRAFFIC SIGNAL CABINET AND EQUIP. (FURNISHED BY COUNTY)	4	EA	\$2,000.00	\$8,000.00
680.809908MO	ACTUATED 8 PHASE GROUND MOUNTED TRAFFIC SIGNAL CABINET AND EQUIP. (PURCHASED FROM COUNTY)	4	EA	\$5,000.00	\$20,000.00
680.810121MO	TRAFFIC SIGNAL MODULE - 12" DIA., RED BALL, LED	34	EA	\$90.00	\$3,060.00
680.810123MO	TRAFFIC SIGNAL MODULE - 12" DIA., YELLOW BALL, LED	34	EA	\$115.00	\$3,910.00
680.810125MO	TRAFFIC SIGNAL MODULE - 12" DIA., GREEN BALL, LED	34	EA	\$125.00	\$4,250.00
680.810128MO	TRAFFIC SIGNAL MODULE - 12" DIA., BIMODAL YELLOW/GREEN ARROW, LED	8	EA	\$175.00	\$1,400.00
680.810308	INSTALL BALL/ ARROW LED TRAFFIC SIGNAL MODULE	110	EA	\$60.00	\$6,600.00
680.810601	TRAFFIC SIGNAL SECTION - POLYCARBONATE, TYPE I, 12 INCH	110	EA	\$225.00	\$24,750.00
680.8111	TRAFFIC SIGNAL BRACKET ASSEMBLY - 1 WAY	34	EA	\$275.00	\$9,350.00
680.81310009	ACCESSIBLE PEDESTRIAN PUSH BUTTON STATION	34	EA	\$500.00	\$17,000.00
680.813104	INSTALL LED PEDESTRIAN SIGNAL MODULE	40	EA	\$60.00	\$2,400.00
680.813109	PEDESTRIAN SIGNAL SECTION - POLYCARBONATE, TYPE I - FOR 16 INCH BY 18 INCH LED MODULE	40	EA	\$375.00	\$15,000.00
680.8141	PEDESTRIAN SIGNAL BRACKET MOUNT ASSEMBLY	23	EA	\$200.00	\$4,600.00
680.820030MO	TRAFFIC SIGNAL POLE MAST ARM COMBINATION ANCHOR BASE (30')	16	EA	\$4,250.00	\$68,000.00
680.8205	OVERHEAD SIGN ASSEMBLY, TYPE E	29	EA	\$600.00	\$17,400.00
680.821618MO	16"X18" PED. SIGNAL - PERSON (FULL) HAND (FULL) 2 DIGIT COUNTDOWN TIMER MODULE - TYPE A UNITS	34	EA	\$350.00	\$11,900.00
680.8225	PEDESTRIAN PUSHBUTTON AND SIGN - WITHOUT POST	6	EA	\$225.00	\$1,350.00
680.854000MO	TRAFFIC SIGNAL MAST ARM, 40 FEET ARM LENGTH	18	EA	\$3,000.00	\$54,000.00
680.995101MO	FIBER-OPTIC CABLE (PURCHASED FROM COUNTY)	5120	LF	\$3.50	\$17,920.00
680.996101MO	INSTALL FIBER-OPTIC CABLE (FURNISHED)	5120	LF	\$5.00	\$25,600.00
683.XXXXXX	CCTV CAMERA	2	EA	\$5,000.00	\$10,000.00
683.XXXXXX	CCTV EQUIPMENT AT INTERSECTION	2	EA	\$3,000.00	\$6,000.00
685.11	WHITE EPOXY REFLECTORIZED PAVEMENT STRIPES - 20 MILS	24000	LF	\$0.75	\$18,000.00
685.12	YELLOW EPOXY REFLECTORIZED PAVEMENT STRIPES - 20 MILS	19000	LF	\$0.75	\$14,250.00
688.01	WHITE PREFORMED REFLECTORIZED PAVEMENT STRIPES	4200	LF	\$2.00	\$8,400.00

**PROJECT: Inner Loop East Reconstruction Project
Alternative 1- Construction Costs
PIN 4940.T7**

JANUARY 2013

ITEM #	DESCRIPTION	QUANTITY	PAY UNIT	UNIT PRICE	AMOUNT
	SUBTOTAL (2015 Dollars)				\$17,195,663.00
	MPT (6%), Survey Operations(4%), Mobilization (4%)		LS		\$2,407,393.80
	Contingency				\$2,462,682.70
	TOTAL CONSTRUCTION COST (2014)				\$22,065,739.50

APPENDIX C

NEPA Checklist

NEPA ASSESSMENT CHECKLIST

(Revised 12-29-03)

Date: **December 2013**

PIN: **4940.T7**

Project Description: **Inner Loop East Reconstruction**

Answer the following questions by checking YES or NO.

I. THRESHOLD QUESTION

1. Does the project involve unusual circumstances as described in 23 CFR ' 771.117(b)? **YES** **NO**

If **YES**, the project does not qualify as a Categorical Exclusion and an EA or EIS is required. You may STOP COMPLETING THE CHECKLIST.

- OR -

If **NO**, continue...

II. AUTOMATIC CATEGORICAL EXCLUSION

2. Is the project an action listed as an Automatic Categorical Exclusion in 23 CFR ' 771.117(c) (C List) and/or is the project an element-specific project classified by FHWA as a Categorical Exclusion on July 22, 1996? **YES** **NO**

If **YES** to question 2, the project qualifies for a C List Categorical Exclusion, "Automatic Categorical Exclusion". You may STOP COMPLETING THE CHECKLIST. The checklist should be included in the appendix of the Final Design Report (or Project Scoping Report/Final Design Report). The CATEGORICAL EXCLUSION DETERMINATION memo is to be sent to the appropriate Main Office Design liaison unit with a copy of the Final Design Report (or Project Scoping Report/Final Design Report). A copy of the CATEGORICAL EXCLUSION DETERMINATION memo must also be sent to the Office of Budget and Finance, Project and Letting Management, and others (see sample DETERMINATION memo attached).

(Note - Even if YES to question 2, there may be specific environmental issues that still require an action such as an EO 11990 Wetland Finding or a determination of effect on cultural resources. The project is still an Automatic Categorical Exclusion but the necessary action must be taken, such as obtaining FHWA's signature on the wetland finding. Refer to the appropriate section of the Environmental Procedures Manual for guidance.)

-OR-

If **NO** to question 2 above, continue below...

III. PROGRAMMATIC CATEGORICAL EXCLUSION

3. Is the project on new location or does it involve a change in the functional classification or added mainline capacity (add through-traffic lanes)? **YES** **NO**

4. Is this a Type I project under 23 CFR 772, "Procedures for Abatement of Highway Traffic Noise and Construction"? **YES** **NO**
5. If the project is located within the limits of a designated sole source aquifer area or the associated stream flow source area, is the drainage pattern altered? **YES** **NO**
6. Does the project involve changes in travel patterns? **YES** **NO**
7. Does the project involve the acquisition of more than minor amounts of temporary or permanent right-of-way (a minor amount of right-of-way is defined as not more than 10 percent of a parcel for parcels under 4 ha (10 acres) in size, 0.4 ha (1 acre) of a parcel 4 ha to 40.5 ha (10 to 100 acres) in size and 1 percent of a parcel for parcels greater than 40.5 ha (100 acres) in size? **YES** **NO**
8. Does the project require a Section 4(f) evaluation and determination in accordance with the FHWA guidance? **YES** **NO**
9. Does the project involve commercial or residential displacement? **YES** **NO**
10. If Section 106 applies, does FHWA's determination indicate an opinion of adverse effect? **YES** **NO**
11. Does the project require an ACOE Nationwide Permit #23 – Approved Categorical Exclusion? * **YES** **NO**
12. Does the project require any work in wetlands requiring an "Individual" Executive Order 11990 Wetland Finding? * **YES** **NO**

13. Has it been determined that the project will significantly encroach upon a flood plain based on preliminary hydraulic analysis and consideration of EO 11988 criteria as appropriate? YES NO
14. Does the project involve construction in, across or adjacent to a river designated as a component proposed for or included in the National System of Wild and Scenic Rivers? YES NO
15. Does the project involve any change in access control? YES NO
16. Does the project involve any known hazardous materials sites or previous land uses with potential for hazardous material remains within the right-of-way? YES NO
17. Does the project occur in an area where there are Federally listed endangered or threatened species or critical habitat? YES NO
18. Is the project, pursuant to EPM Chapter 1A and Table 2 and Table 3 of 40 CFR Parts 51 and 93, non-exempt or does it exceed any ambient air quality standard? YES NO
19. Does the project lack consistency with the New York State Coastal Zone Management Plan and policies of the Department of State, Office of Coastal Zone Management? YES NO
20. Does the project impact or acquire any Prime or Unique Farmland as defined in 7 CFR Part 657 of the Federal Farmland Protection Policy Act and

are there outstanding compliance activities necessary? (Note: Interpret compliance activity to mean completion of Form AD 1006.)

YES NO

If **NO** for questions, 3-20, go on to answer question 21...

-OR-

If **YES** to any question 3-20, project will not qualify as a Programmatic Categorical Exclusion. Answer questions 21 and 22 for documentation only and go on to question 23...

21. Does the project involve the use of a temporary road, detour or ramp closure?

YES NO

If **NO** to questions 3-20 and **NO** to question 21, the project qualifies as a Programmatic Categorical Exclusion. You may **STOP COMPLETING THE CHECKLIST**. The checklist should be included in the appendix of the Final Design Report (or Scope Summary Memorandum/Final Design Report). The **CATEGORICAL EXCLUSION DETERMINATION** memo is to be sent to the appropriate Main Office Design liaison unit with a copy of the Final Design Report (or Scope Summary Memorandum/Final Design Report). A copy of the Categorical Exclusion memo must also be sent to the Office of Budget and Finance, Project and Letting Management, and others.

-OR-

If **YES** to question 21, preparer should complete question 22 (i-v). If questions 3-20 are **NO** and 21 is **YES**, the project will still qualify as a Programmatic Categorical Exclusion if questions 22 (i-v) are **YES**.

22. Since the project involves the use of temporary road, detour or ramp closure, will all of the following conditions be met:

i. Provisions will be made for pedestrian access, where warranted, and access by local traffic and so posted.

YES NO

ii. Through-traffic dependent business will not be adversely affected.

YES NO

iii. The detour or ramp closure, to the extent possible, will not interfere with any local special event or festival.

YES NO

iv. The temporary road, detour or ramp closure

does not substantially change the environmental consequences of the action.

YES NO

- v. There is no substantial controversy associated with the temporary road, detour or ramp closure.

YES NO

If questions 3-20 are **NO**, 21 is **YES** and 22 (i-v) are YES, the project qualifies for a Programmatic Categorical Exclusion. You may STOP COMPLETING THE CHECKLIST. The checklist should be included in the appendix of the Final Design Report (or Scope Summary Memorandum/Final Design Report). The CATEGORICAL EXCLUSION DETERMINATION memo should be sent to the appropriate Main Office Design liaison unit with a copy of the Final Design Report (or Scope Summary Memorandum/Final Design Report.) A copy of the CATEGORICAL EXCLUSION DETERMINATION memo must also be sent to the Office of Budget and Finance, Project and Letting Management, and others.

-OR-

If questions 3-20 are **NO** or effect is **clarified**, 21 is **YES** and any part of 22 is **NO**, go on to question 23.

23. Is the project section listed in 23 CFR ' 771.117(d) (D List) or is the project an action similar to those listed in 23 CFR ' 771.117(d)?

YES NO

For those questions which precluded a Programmatic Categorical Exclusion, documentation should be provided for any **YES** response to questions 3-20 or for a **NO** response to any part of questions 22 (i-v). This documentation, as well as the checklist, should be included in the Design Approval Document, i.e., Final Design Report, etc., to be submitted to the Main Office/FHWA Design liaison unit for submission to the FHWA Division for classification of the project as a D List Categorical Exclusion, "Categorical Exclusion with Documentation".

Question 3: *Is the project on new location or does it involve a change in the functional classification or added mainline capacity (add through-traffic lanes)?*

Documentation: The removal of the Inner Loop Expressway (Principal Arterial – Expressway – NHS) will occur as part of the project improvements. Access through the corridor will be maintained via the combined infrastructure of Howell Street (Minor Urban Arterial - Non NHS) and Union Street (Minor Urban Arterial – Non NHS). Howell Street (Minor Urban Arterial) will be realigned however; the realignment will occur within the existing ROW over the location of the former expressway corridor.

Question 4: *Is this a Type I project under 23 CFR 772, "Procedures for Abatement of Highway Traffic Noise and Construction"?*

Documentation: A Noise Analysis was performed to determine the effect of the proposed design alternative on transportation related noise impacts within the study area of the reconstruction project. The methods used in this analysis are in accordance with the provisions and procedures of the policies stated in the federal noise regulations (23 CFR 772), and NYSDOT's *The Environmental Manual* (TEM). For the impacted areas, all noise abatement measures listed in 23 CFR Part 772.13(c) were examined and evaluated for reducing the dBA level. In all instances, the noise abatement measures were considered physically infeasible, economically unreasonable, or undesirable to the affected residents. Therefore, no noise abatement measures are recommended for this corridor

With respect to an overall comparison between the No-Build and Build alternatives, the variation in the results ranged from 0-2 dBA for all receivers and 0-1 dBA for the five impacted receivers. Since 3 dBA is generally considered the minimum decibel difference noticeable to the human ear, the differences in noise levels between the No-Build and Build alternatives for the analyzed areas are essentially negligible and primarily imperceptible to the human ear. Therefore, consideration of the noise level differences between the No-Build and Build alternatives to favor one alternative over another is not recommended.

Question 6: *Does the project involve changes in travel patterns?*

Documentation: This project will alter travel patterns through the Inner Loop corridor. The Inner Loop Expressway will be removed and the combined Howell Street and Union Street facilities will be upgraded from frontage roads to form continuous, two-way arterial urban streets. Traffic that currently uses the Inner Loop will use the new Howell and Union Street arterials. A detailed traffic analysis has been performed resulting in no significant impacts to surrounding facilities.

Question 10: *If Section 106 applies, does FHWA's determination indicate an opinion of adverse effect?*

Documentation: The New York State Department of Transportation applied the criteria of adverse effect (36 CFR 800.S(a)(1)) to historic properties within the area of potential effects (APE) for the proposed undertaking. NYSDOT concluded that the project would have *No Adverse Effect* on historic properties in accordance with 36 CFR 800.S(b). Based on review of the Finding Documentation and Phase II report prepared for this project, the SHPO disagreed with the NYSDOT's assessment of the project's effects and provided a

letter proposing an Adverse Effect finding based on the extent of archaeological excavations at the Amos Burrows Site, a property determined eligible for the National Register of Historic Places. The SHPO concurred with the recommendation that no further archaeological excavation is warranted for the site (see attached letter dated February 26, 2014). As described above, an MOA has been signed by all parties to mitigate this Adverse Effect.

Question 15: *Does the project involve any change in access control?*

Documentation: The new corridor will no longer have full access control as it will be reconstructed as arterial urban streets.

APPENDIX D

SEQR Documentation

**Full Environmental Assessment Form
Part 1 - Project and Setting**

Instructions for Completing Part 1

Part 1 is to be completed by the applicant or project sponsor. Responses become part of the application for approval or funding, are subject to public review, and may be subject to further verification.

Complete Part 1 based on information currently available. If additional research or investigation would be needed to fully respond to any item, please answer as thoroughly as possible based on current information; indicate whether missing information does not exist, or is not reasonably available to the sponsor; and, when possible, generally describe work or studies which would be necessary to update or fully develop that information.

Applicants/sponsors must complete all items in Sections A & B. In Sections C, D & E, most items contain an initial question that must be answered either "Yes" or "No". If the answer to the initial question is "Yes", complete the sub-questions that follow. If the answer to the initial question is "No", proceed to the next question. Section F allows the project sponsor to identify and attach any additional information. Section G requires the name and signature of the project sponsor to verify that the information contained in Part 1 is accurate and complete.

A. Project and Sponsor Information.

Name of Action or Project: Inner Loop East Reconstruction Project		
Project Location (describe, and attach a general location map): Inner Loop from East Main Street to South Clinton Avenue, Rochester, New York		
Brief Description of Proposed Action (include purpose or need): See Attachment #1		
Name of Applicant/Sponsor: City of Rochester, City Hall		Telephone: E-Mail:
Address: 30 Church Street		
City/PO: Rochester	State: New York	Zip Code: 14614
Project Contact (if not same as sponsor; give name and title/role): Mr. James McIntosh, P.E., City Engineer		Telephone: 585-428-6828 E-Mail: Jim.McIntosh@cityofrochester.gov
Address: 30 Church Street		
City/PO: Rochester	State: New York	Zip Code: 14614
Property Owner (if not same as sponsor): State of New York		Telephone: E-Mail:
Address:		
City/PO:	State:	Zip Code:

B. Government Approvals

B. Government Approvals Funding, or Sponsorship. ("Funding" includes grants, loans, tax relief, and any other forms of financial assistance)		
Government Entity	If Yes: Identify Agency and Approval(s) Required	Application Date (Actual or projected)
a. City Council, Town Board, <input checked="" type="checkbox"/> Yes <input type="checkbox"/> No or Village Board of Trustees	Funding Land Transfers Official Map Amendment and acquisitions.	Pending
b. City, Town or Village <input checked="" type="checkbox"/> Yes <input type="checkbox"/> No Planning Board or Commission	Subdivision Approval	Pending
c. City Council, Town or <input type="checkbox"/> Yes <input checked="" type="checkbox"/> No Village Zoning Board of Appeals		
d. Other local agencies <input checked="" type="checkbox"/> Yes <input type="checkbox"/> No	See Attachment #2	Pending
e. County agencies <input checked="" type="checkbox"/> Yes <input type="checkbox"/> No	Monroe County Department of Transportation - Traffic signal coordination	Pending
f. Regional agencies <input type="checkbox"/> Yes <input checked="" type="checkbox"/> No		
g. State agencies <input checked="" type="checkbox"/> Yes <input type="checkbox"/> No	NYSDOT - Design Approval, Land Transfer NYSDEC - SWPPP and Fill Material Approval	Pending
h. Federal agencies <input checked="" type="checkbox"/> Yes <input type="checkbox"/> No	FHWA - Funding, project review	Pending
i. Coastal Resources.		
i. Is the project site within a Coastal Area, or the waterfront area of a Designated Inland Waterway? If Yes,		<input type="checkbox"/> Yes <input checked="" type="checkbox"/> No
ii. Is the project site located in a community with an approved Local Waterfront Revitalization Program?		<input type="checkbox"/> Yes <input checked="" type="checkbox"/> No
iii. Is the project site within a Coastal Erosion Hazard Area?		<input type="checkbox"/> Yes <input checked="" type="checkbox"/> No

C. Planning and Zoning

C.1. Planning and zoning actions.	
Will administrative or legislative adoption, or amendment of a plan, local law, ordinance, rule or regulation be the only approval(s) which must be granted to enable the proposed action to proceed? <input type="checkbox"/> Yes <input checked="" type="checkbox"/> No	
<ul style="list-style-type: none"> • If Yes, complete sections C, F and G. • If No, proceed to question C.2 and complete all remaining sections and questions in Part I 	
C.2. Adopted land use plans.	
a. Do any municipally- adopted (city, town, village or county) comprehensive land use plan(s) include the site where the proposed action would be located? <input checked="" type="checkbox"/> Yes <input type="checkbox"/> No	
If Yes, does the comprehensive plan include specific recommendations for the site where the proposed action would be located? <input checked="" type="checkbox"/> Yes <input type="checkbox"/> No	
b. Is the site of the proposed action within any local or regional special planning district (for example: Greenway Brownfield Opportunity Area (BOA); designated State or Federal heritage area; watershed management plan; or other?) <input type="checkbox"/> Yes <input checked="" type="checkbox"/> No	
If Yes, identify the plan(s): _____ _____	
c. Is the proposed action located wholly or partially within an area listed in an adopted municipal open space plan, or an adopted municipal farmland protection plan? <input type="checkbox"/> Yes <input checked="" type="checkbox"/> No	
If Yes, identify the plan(s): _____ _____	

C.3. Zoning

a. Is the site of the proposed action located in a municipality with an adopted zoning law or ordinance. Yes No
 If Yes, what is the zoning classification(s) including any applicable overlay district?
 See Figure 2. CCD-B, CCD-E, CCD-M, CCD-T _____

b. Is the use permitted or allowed by a special or conditional use permit? Yes No

c. Is a zoning change requested as part of the proposed action? Yes No
 If Yes,
 i. What is the proposed new zoning for the site? _____

C.4. Existing community services.

a. In what school district is the project site located? Rochester City School District

b. What police or other public protection forces serve the project site?
Rochester Police Department

c. Which fire protection and emergency medical services serve the project site?
Rochester Fire Department

d. What parks serve the project site?
Wadsworth Park is adjacent to the project area

D. Project Details

D.1. Proposed and Potential Development

a. What is the general nature of the proposed action (e.g., residential, industrial, commercial, recreational, if mixed, include all components)? Reconstruction of the existing highway infrastructure and mixed use development.

b. a. Total acreage of the site of the proposed action? _____ 24.6 acres
 b. Total acreage to be physically disturbed? _____ 24.6 acres
 c. Total acreage (project site and any contiguous properties) owned or controlled by the applicant or project sponsor? _____ 60% City 40% State acres

c. Is the proposed action an expansion of an existing project or use? Yes No
 i. If Yes, what is the approximate percentage of the proposed expansion and identify the units (e.g., acres, miles, housing units, square feet)? % _____ Units: _____

d. Is the proposed action a subdivision, or does it include a subdivision? Yes No
 If Yes,
 i. Purpose or type of subdivision? (e.g., residential, industrial, commercial; if mixed, specify types)
Abandonment of the highway boundaries for purposes of future development
 ii. Is a cluster/conservation layout proposed? Yes No
 iii. Number of lots proposed? TBD
 iv. Minimum and maximum proposed lot sizes? Minimum TBD Maximum TBD

e. Will proposed action be constructed in multiple phases? Yes No
 i. If No, anticipated period of construction: _____ months
 ii. If Yes:
 • Total number of phases anticipated TBD
 • Anticipated commencement date of phase 1 (including demolition) Nov month 2014 year
 • Anticipated completion date of final phase TBD month TBD year
 • Generally describe connections or relationships among phases, including any contingencies where progress of one phase may determine timing or duration of future phases: _____
See Attachment #3.

f. Does the project include new residential uses? Yes No
 If Yes, show numbers of units proposed.

	<u>One Family</u>	<u>Two Family</u>	<u>Three Family</u>	<u>Multiple Family (four or more)</u>
Initial Phase	TBD			
At completion of all phases	48	NA	NA	577

g. Does the proposed action include new non-residential construction (including expansions)? Yes No
 If Yes,
 i. Total number of structures +10
 ii. Dimensions (in feet) of largest proposed structure: 2-6stories height; TBD width; and TBD length
 iii. Approximate extent of building space to be heated or cooled: 100% square feet

h. Does the proposed action include construction or other activities that will result in the impoundment of any liquids, such as creation of a water supply, reservoir, pond, lake, waste lagoon or other storage? Yes No
 If Yes,
 i. Purpose of the impoundment: _____
 ii. If a water impoundment, the principal source of the water: Ground water Surface water streams Other specify: _____
 iii. If other than water, identify the type of impounded/contained liquids and their source. _____
 iv. Approximate size of the proposed impoundment. Volume: _____ million gallons; surface area: _____ acres
 v. Dimensions of the proposed dam or impounding structure: _____ height; _____ length
 vi. Construction method/materials for the proposed dam or impounding structure (e.g., earth fill, rock, wood, concrete): _____

D.2. Project Operations

a. Does the proposed action include any excavation, mining, or dredging, during construction, operations, or both? Yes No
 (Not including general site preparation, grading or installation of utilities or foundations where all excavated materials will remain onsite)
 If Yes:
 i. What is the purpose of the excavation or dredging? Rebuild the highway infrastructure
 ii. How much material (including rock, earth, sediments, etc.) is proposed to be removed from the site?
 • Volume (specify tons or cubic yards): None. Excavated material to remain
 • Over what duration of time? Up to 3 years.
 iii. Describe nature and characteristics of materials to be excavated or dredged, and plans to use, manage or dispose of them.
Excavation of highway infrastructure (including pavement and sidewalks) to be reused as fill on-site.
 iv. Will there be onsite dewatering or processing of excavated materials? Yes No
 If yes, describe. _____
 v. What is the total area to be dredged or excavated? 14.3 acres
 vi. What is the maximum area to be worked at any one time? 14.3 acres
 vii. What would be the maximum depth of excavation or dredging? 10 feet
 viii. Will the excavation require blasting? Yes No
 ix. Summarize site reclamation goals and plan: _____
Approximately 120,000 cubic yards of clean fill will be brought in to bring the project site up to the needed grade. Clean fill will be transported to the project site via the adjacent roadway network over an estimated three year period as fill material becomes available. A new Roadway network, greenspace and developable parcels will be constructed.

b. Would the proposed action cause or result in alteration of, increase or decrease in size of, or encroachment into any existing wetland, waterbody, shoreline, beach or adjacent area? Yes No
 If Yes:
 i. Identify the wetland or waterbody which would be affected (by name, water index number, wetland map number or geographic description): _____

ii. Describe how the proposed action would affect that waterbody or wetland, e.g. excavation, fill, placement of structures, or alteration of channels, banks and shorelines. Indicate extent of activities, alterations and additions in square feet or acres:

There are no waterbodies or wetlands present within the project area

iii. Will proposed action cause or result in disturbance to bottom sediments?

Yes No

If Yes, describe:

iv. Will proposed action cause or result in the destruction or removal of aquatic vegetation?

Yes No

If Yes:

- acres of aquatic vegetation proposed to be removed _____
- expected acreage of aquatic vegetation proposed to be removed _____
- purpose of proposed removal (e.g. beach clearing, invasive species control, boat access): _____

- proposed method of plant removal: _____

- if chemical/herbicide treatment will be used, specify product(s): _____

v. Describe any proposed reclamation/mitigation following disturbance: _____

c. Will the proposed action use, or create a new demand for water?

Yes No

If Yes:

i. Total anticipated water usage/demand per day: _____ 158,522 gallons/day

ii. Will the proposed action obtain water from an existing public water supply?

Yes No

If Yes:

- Name of district or service area: City of Rochester Water Bureau

- Does the existing public water supply have capacity to serve the proposal?

Yes No

- Is the project site in the existing district?

Yes No

- Is expansion of the district needed?

Yes No

- Do existing lines serve the project site?

Yes No

iii. Will line extension within an existing district be necessary to supply the project?

Yes No

If Yes:

- Describe extensions or capacity expansions proposed to serve this project: _____

- Source(s) of supply for the district: City of Rochester Water Bureau

iv. Is a new water supply district or service area proposed to be formed to serve the project site?

Yes No

If Yes:

- Applicant/sponsor for new district: _____

- Date application submitted or anticipated: _____

- Proposed source(s) of supply for new district: _____

v. If a public water supply will not be used, describe plans to provide water supply for the project: _____

vi. If water supply will be from wells (public or private), maximum pumping capacity: _____ gallons/minute.

d. Will the proposed action generate liquid wastes?

Yes No

If Yes:

i. Total anticipated liquid waste generation per day: _____ 158,522 gallons/day

ii. Nature of liquid wastes to be generated (e.g. sanitary wastewater, industrial, if combination, describe all components and approximate volumes or proportions of each): _____

Sanitary Wastewater

iii. Will the proposed action use any existing public wastewater treatment facilities?

Yes No

If Yes:

- Name of wastewater treatment plant to be used: Van Lare Sewage Treatment Plant

- Name of district: Rochester District

- Does the existing wastewater treatment plant have capacity to serve the project?

Yes No

- Is the project site in the existing district?

Yes No

- Is expansion of the district needed?

Yes No

• Do existing sewer lines serve the project site? Yes No
 • Will line extension within an existing district be necessary to serve the project? Yes No
 If Yes:
 • Describe extensions or capacity expansions proposed to serve this project: _____

iv. Will a new wastewater (sewage) treatment district be formed to serve the project site? Yes No
 If Yes:
 • Applicant/sponsor for new district: _____
 • Date application submitted or anticipated: _____
 • What is the receiving water for the wastewater discharge? _____
 v. If public facilities will not be used, describe plans to provide wastewater treatment for the project, including specifying proposed receiving water (name and classification if surface discharge, or describe subsurface disposal plans):
 N/A

vi. Describe any plans or designs to capture, recycle or reuse liquid waste: _____
 None

e. Will the proposed action disturb more than one acre and create stormwater runoff, either from new point sources (i.e. ditches, pipes, swales, curbs, gutters or other concentrated flows of stormwater) or non-point source (i.e. sheet flow) during construction or post construction? Yes No
 If Yes:
 i. How much impervious surface will the project create in relation to total size of project parcel?
 _____ Square feet or 24.6 acres (impervious surface)
 _____ Square feet or 24.6 acres (parcel size)
 ii. Describe types of new point sources. Pavement, sidewalks, roof drain runoff to the existing City of Rochester sewer system.

 iii. Where will the stormwater runoff be directed (i.e. on-site stormwater management facility/structures, adjacent properties, groundwater, on-site surface water or off-site surface waters)?
Stormwater Sewer Inlets

 • If to surface waters, identify receiving water bodies or wetlands: _____

 • Will stormwater runoff flow to adjacent properties? Yes No
 iv. Does proposed plan minimize impervious surfaces, use pervious materials or collect and re-use stormwater? Yes No

f. Does the proposed action include, or will it use on-site, one or more sources of air emissions, including fuel combustion, waste incineration, or other processes or operations? Yes No
 If Yes, identify:
 i. Mobile sources during project operations (e.g., heavy equipment, fleet or delivery vehicles)

 ii. Stationary sources during construction (e.g., power generation, structural heating, batch plant, crushers)

 iii. Stationary sources during operations (e.g., process emissions, large boilers, electric generation)

g. Will any air emission sources named in D.2.f (above), require a NY State Air Registration, Air Facility Permit, or Federal Clean Air Act Title IV or Title V Permit? Yes No
 If Yes:
 i. Is the project site located in an Air quality non-attainment area? (Area routinely or periodically fails to meet ambient air quality standards for all or some parts of the year) Yes No
 ii. In addition to emissions as calculated in the application, the project will generate:
 • _____ Tons/year (short tons) of Carbon Dioxide (CO₂)
 • _____ Tons/year (short tons) of Nitrous Oxide (N₂O)
 • _____ Tons/year (short tons) of Perfluorocarbons (PFCs)
 • _____ Tons/year (short tons) of Sulfur Hexafluoride (SF₆)
 • _____ Tons/year (short tons) of Carbon Dioxide equivalent of Hydrofluorocarbons (HFCs)
 • _____ Tons/year (short tons) of Hazardous Air Pollutants (HAPs)

h. Will the proposed action generate or emit methane (including, but not limited to, sewage treatment plants, landfills, composting facilities)? Yes No

If Yes:

i. Estimate methane generation in tons/year (metric): _____

ii. Describe any methane capture, control or elimination measures included in project design (e.g., combustion to generate heat or electricity, flaring): _____

i. Will the proposed action result in the release of air pollutants from open-air operations or processes, such as quarry or landfill operations? Yes No

If Yes: Describe operations and nature of emissions (e.g., diesel exhaust, rock particulates/dust): _____

j. Will the proposed action result in a substantial increase in traffic above present levels or generate substantial new demand for transportation facilities or services? Yes No

If Yes:

i. When is the peak traffic expected (Check all that apply): Morning Evening Weekend
 Randomly between hours of _____ to _____.

ii. For commercial activities only, projected number of semi-trailer truck trips/day: _____ Unknown

iii. Parking spaces: Existing _____ Unknown _____ Proposed 1,385 Net increase/decrease _____ Unknown

iv. Does the proposed action include any shared use parking? Yes No

v. If the proposed action includes any modification of existing roads, creation of new roads or change in existing access, describe:
See project description and Figure 1.

vi. Are public/private transportation service(s) or facilities available within 1/2 mile of the proposed site? Yes No

vii. Will the proposed action include access to public transportation or accommodations for use of hybrid, electric or other alternative fueled vehicles? Yes No

viii. Will the proposed action include plans for pedestrian or bicycle accommodations for connections to existing pedestrian or bicycle routes? Yes No

k. Will the proposed action (for commercial or industrial projects only) generate new or additional demand for energy? Yes No

If Yes:

i. Estimate annual electricity demand during operation of the proposed action: _____
Coordination with Rochester Gas & Electric will occur once future development uses are known

ii. Anticipated sources/suppliers of electricity for the project (e.g., on-site combustion, on-site renewable, via grid/local utility, or other):
Rochester Gas and Electric

iii. Will the proposed action require a new, or an upgrade to, an existing substation? Yes No

l. Hours of operation. Answer all items which apply.

i. During Construction:		ii. During Operations:	
• Monday - Friday:	<u>7:00 am - 5:00 pm</u>	• Monday - Friday:	<u>TBD</u>
• Saturday:	<u>As needed, 7:00 am - 5:00 pm</u>	• Saturday:	<u>TBD</u>
• Sunday:	<u>No</u>	• Sunday:	<u>TBD</u>
• Holidays:	<u>No</u>	• Holidays:	<u>TBD</u>

m. Will the proposed action produce noise that will exceed existing ambient noise levels during construction, operation, or both? Yes No
 If yes:
 i. Provide details including sources, time of day and duration:
 Construction activities during hours described in previous section _____

ii. Will proposed action remove existing natural barriers that could act as a noise barrier or screen? Yes No
 Describe: Inner Loop is below grade, sidewalls will be removed via grading. _____

n. Will the proposed action have outdoor lighting? Yes No
 If yes:
 i. Describe source(s), location(s), height of fixture(s), direction/aim, and proximity to nearest occupied structures:
 Existing street lighting fixtures will be replaced as part of the project. Specific details will be determined by the City Street Lighting Division _____

ii. Will proposed action remove existing natural barriers that could act as a light barrier or screen? Yes No
 Describe: _____

o. Does the proposed action have the potential to produce odors for more than one hour per day? Yes No
 If Yes, describe possible sources, potential frequency and duration of odor emissions, and proximity to nearest occupied structures: _____

p. Will the proposed action include any bulk storage of petroleum (combined capacity of over 1,100 gallons) or chemical products (185 gallons in above ground storage or an amount in underground storage)? Yes No
 If Yes:
 i. Product(s) to be stored _____
 ii. Volume(s) _____ per unit time _____ (e.g., month, year)
 iii. Generally describe proposed storage facilities: _____

q. Will the proposed action (commercial, industrial and recreational projects only) use pesticides (i.e., herbicides, insecticides) during construction or operation? Yes No
 If Yes:
 i. Describe proposed treatment(s):

ii. Will the proposed action use Integrated Pest Management Practices? Yes No

r. Will the proposed action (commercial or industrial projects only) involve or require the management or disposal of solid waste (excluding hazardous materials)? Yes No
 If Yes:
 i. Describe any solid waste(s) to be generated during construction or operation of the facility:
 • Construction: 12,000 cubic yards tons per 3 years (unit of time)
 • Operation: TBD tons per Month (unit of time)
 ii. Describe any proposals for on-site minimization, recycling or reuse of materials to avoid disposal as solid waste:
 • Construction: Roadway demolition debris will be reused on-site for fill.

 • Operation: TBD

iii. Proposed disposal methods/facilities for solid waste generated on-site:
 • Construction: Excavation of roadway millings.

 • Operation: Sanitary waste to be hauled by City of Rochester to a NYSDEC approved landfill facility.

s. Does the proposed action include construction or modification of a solid waste management facility? Yes No

If Yes:

i. Type of management or handling of waste proposed for the site (e.g., recycling or transfer station, composting, landfill, or other disposal activities): _____

ii. Anticipated rate of disposal/processing:

- _____ Tons/month, if transfer or other non-combustion/thermal treatment, or
- _____ Tons/hour, if combustion or thermal treatment

iii. If landfill, anticipated site life: _____ years

t. Will proposed action at the site involve the commercial generation, treatment, storage, or disposal of hazardous waste? Yes No

If Yes:

i. Name(s) of all hazardous wastes or constituents to be generated, handled or managed at facility: _____

ii. Generally describe processes or activities involving hazardous wastes or constituents: _____

iii. Specify amount to be handled or generated _____ tons/month

iv. Describe any proposals for on-site minimization, recycling or reuse of hazardous constituents: _____

v. Will any hazardous wastes be disposed at an existing offsite hazardous waste facility? Yes No

If Yes: provide name and location of facility: _____

If No: describe proposed management of any hazardous wastes which will not be sent to a hazardous waste facility: _____

E. Site and Setting of Proposed Action

E.1. Land uses on and surrounding the project site

a. Existing land uses.

i. Check all uses that occur on, adjoining and near the project site.

Urban Industrial Commercial Residential (suburban) Rural (non-farm)

Forest Agriculture Aquatic Other (specify): _____

ii. If mix of uses, generally describe:

Above listed uses are intermixed in an urban development setting

b. Land uses and covertypes on the project site.

Land use or Covertype	Current Acreage	Acreage After Project Completion	Change (Acres +/-)
• Roads, buildings, and other paved or impervious surfaces	24.6	24.6	0
• Forested	0	0	0
• Meadows, grasslands or brushlands (non-agricultural, including abandoned agricultural)	0	0	0
• Agricultural (includes active orchards, field, greenhouse etc.)	0	0	0
• Surface water features (lakes, ponds, streams, rivers, etc.)	0	0	0
• Wetlands (freshwater or tidal)	0	0	0
• Non-vegetated (bare rock, earth or fill)	0	0	0
• Other Describe: _____			

c. Is the project site presently used by members of the community for public recreation? Yes No
 i. If Yes: explain: _____

d. Are there any facilities serving children, the elderly, people with disabilities (e.g., schools, hospitals, licensed day care centers, or group homes) within 1500 feet of the project site? Yes No
 If Yes,
 i. Identify Facilities:
World of Inquiry School #58, 200 University Avenue

e. Does the project site contain an existing dam? Yes No
 If Yes:
 i. Dimensions of the dam and impoundment:
 • Dam height: _____ feet
 • Dam length: _____ feet
 • Surface area: _____ acres
 • Volume impounded: _____ gallons OR acre-feet
 ii. Dam's existing hazard classification: _____
 iii. Provide date and summarize results of last inspection:

f. Has the project site ever been used as a municipal, commercial or industrial solid waste management facility, or does the project site adjoin property which is now, or was at one time, used as a solid waste management facility? Yes No
 If Yes:
 i. Has the facility been formally closed? Yes No
 • If yes, cite sources/documentation: _____
 ii. Describe the location of the project site relative to the boundaries of the solid waste management facility:

 iii. Describe any development constraints due to the prior solid waste activities: _____

g. Have hazardous wastes been generated, treated and/or disposed of at the site, or does the project site adjoin property which is now or was at one time used to commercially treat, store and/or dispose of hazardous waste? Yes No
 If Yes:
 i. Describe waste(s) handled and waste management activities, including approximate time when activities occurred:

h. Potential contamination history. Has there been a reported spill at the proposed project site, or have any remedial actions been conducted at or adjacent to the proposed site? Yes No
 If Yes:
 i. Is any portion of the site listed on the NYSDEC Spills Incidents database or Environmental Site Remediation database? Check all that apply: Yes No
 Yes – Spills Incidents database Provide DEC ID number(s): Appendix A
 Yes – Environmental Site Remediation database Provide DEC ID number(s): Appendix A
 Neither database
 ii. If site has been subject of RCRA corrective activities, describe control measures:

 iii. Is the project within 2000 feet of any site in the NYSDEC Environmental Site Remediation database? Yes No
 If yes, provide DEC ID number(s): See Preliminary Screening Report (Appendix A.)
 iv. If yes to (i), (ii) or (iii) above, describe current status of site(s):

v. Is the project site subject to an institutional control limiting property uses? Yes No

- If yes, DEC site ID number: _____
- Describe the type of institutional control (e.g., deed restriction or easement): _____
- Describe any use limitations: _____
- Describe any engineering controls: _____
- Will the project affect the institutional or engineering controls in place? Yes No
- Explain: _____

E.2. Natural Resources On or Near Project Site

a. What is the average depth to bedrock on the project site? _____ 10 +/- _____ feet

b. Are there bedrock outcroppings on the project site? Yes No
 If Yes, what proportion of the site is comprised of bedrock outcroppings? _____ %

c. Predominant soil type(s) present on project site:

Urban Land	_____	80 %
Other	_____	20 %
		_____ %

d. What is the average depth to the water table on the project site? Average: _____ 10 feet

e. Drainage status of project site soils: Well Drained: _____ 10 % of site
 Moderately Well Drained: _____ % of site
 Poorly Drained _____ 90 % of site

f. Approximate proportion of proposed action site with slopes: 0-10%: _____ 100 % of site
 10-15%: _____ % of site
 15% or greater: _____ % of site

g. Are there any unique geologic features on the project site? Yes No
 If Yes, describe: _____

h. Surface water features.

i. Does any portion of the project site contain wetlands or other waterbodies (including streams, rivers, ponds or lakes)? Yes No

ii. Do any wetlands or other waterbodies adjoin the project site? Yes No
 If Yes to either *i* or *ii*, continue. If No, skip to E.2.i.

iii. Are any of the wetlands or waterbodies within or adjoining the project site regulated by any federal, state or local agency? Yes No

iv. For each identified regulated wetland and waterbody on the project site, provide the following information:

- Streams: Name _____ Classification _____
- Lakes or Ponds: Name _____ Classification _____
- Wetlands: Name _____ Approximate Size _____
- Wetland No. (if regulated by DEC) _____

v. Are any of the above water bodies listed in the most recent compilation of NYS water quality-impaired waterbodies? Yes No
 If yes, name of impaired water body/bodies and basis for listing as impaired: _____

i. Is the project site in a designated Floodway? Yes No

j. Is the project site in the 100 year Floodplain? Yes No

k. Is the project site in the 500 year Floodplain? Yes No

l. Is the project site located over, or immediately adjoining, a primary, principal or sole source aquifer? Yes No
 If Yes:
 i. Name of aquifer: _____

m. Identify the predominant wildlife species that occupy or use the project site: _____ None _____ None _____ None _____	
n. Does the project site contain a designated significant natural community? <input type="checkbox"/> Yes <input checked="" type="checkbox"/> No If Yes:	
<i>i.</i> Describe the habitat/community (composition, function, and basis for designation): _____ _____	
<i>ii.</i> Source(s) of description or evaluation: _____	
<i>iii.</i> Extent of community/habitat:	
<ul style="list-style-type: none"> • Currently: _____ acres • Following completion of project as proposed: _____ acres • Gain or loss (indicate + or -): _____ acres 	
o. Does project site contain any species of plant or animal that is listed by the federal government or NYS as endangered or threatened, or does it contain any areas identified as habitat for an endangered or threatened species? <input type="checkbox"/> Yes <input checked="" type="checkbox"/> No	
American Burying Beetle (Rare Animal) was listed but no longer exists in the project vicinity. See Attachment Number 3.	
p. Does the project site contain any species of plant or animal that is listed by NYS as rare, or as a species of special concern? <input type="checkbox"/> Yes <input checked="" type="checkbox"/> No	
The American Burying Beetle appears on the NYSDEC list of rare animals. However, this species is no longer present in NYS.	
q. Is the project site or adjoining area currently used for hunting, trapping, fishing or shell fishing? <input type="checkbox"/> Yes <input checked="" type="checkbox"/> No If yes, give a brief description of how the proposed action may affect that use: _____ _____	
E.3. Designated Public Resources On or Near Project Site	
a. Is the project site, or any portion of it, located in a designated agricultural district certified pursuant to Agriculture and Markets Law, Article 25-AA, Section 303 and 304? <input type="checkbox"/> Yes <input checked="" type="checkbox"/> No If Yes, provide county plus district name/number: _____	
b. Are agricultural lands consisting of highly productive soils present? <input type="checkbox"/> Yes <input checked="" type="checkbox"/> No <i>i.</i> If Yes: acreage(s) on project site? _____ <i>ii.</i> Source(s) of soil rating(s): _____	
c. Does the project site contain all or part of, or is it substantially contiguous to, a registered National Natural Landmark? <input type="checkbox"/> Yes <input checked="" type="checkbox"/> No If Yes:	
<i>i.</i> Nature of the natural landmark: <input type="checkbox"/> Biological Community <input type="checkbox"/> Geological Feature <i>ii.</i> Provide brief description of landmark, including values behind designation and approximate size/extent: _____ _____	
d. Is the project site located in or does it adjoin a state listed Critical Environmental Area? <input type="checkbox"/> Yes <input checked="" type="checkbox"/> No If Yes:	
<i>i.</i> CEA name: _____ <i>ii.</i> Basis for designation: _____ <i>iii.</i> Designating agency and date: _____	

c. Does the project site contain, or is it substantially contiguous to, a building, archaeological site, or district which is listed on, or has been nominated by the NYS Board of Historic Preservation for inclusion on, the State or National Register of Historic Places?	<input checked="" type="checkbox"/> Yes <input type="checkbox"/> No
If Yes:	
<i>i.</i> Nature of historic/archaeological resource: <input type="checkbox"/> Archaeological Site <input type="checkbox"/> Historic Building or District	
<i>ii.</i> Name: <u>See Attachment #4</u>	
<i>iii.</i> Brief description of attributes on which listing is based: <u>See Cultural Resources Study</u>	
f. Is the project site, or any portion of it, located in or adjacent to an area designated as sensitive for archaeological sites on the NY State Historic Preservation Office (SHPO) archaeological site inventory?	<input checked="" type="checkbox"/> Yes <input type="checkbox"/> No
g. Have additional archaeological or historic site(s) or resources been identified on the project site?	
If Yes:	
<i>i.</i> Describe possible resource(s): <u>See Cultural Resources Study</u>	
<i>ii.</i> Basis for identification: _____	
h. Is the project site within five miles of any officially designated and publicly accessible federal, state, or local scenic or aesthetic resource?	<input type="checkbox"/> Yes <input checked="" type="checkbox"/> No
If Yes:	
<i>i.</i> Identify resource: _____	
<i>ii.</i> Nature of, or basis for, designation (e.g., established highway overlook, state or local park, state historic trail or scenic byway, etc.): _____	
<i>iii.</i> Distance between project and resource: _____ miles.	
i. Is the project site located within a designated river corridor under the Wild, Scenic and Recreational Rivers Program 6 NYCRR 666?	<input type="checkbox"/> Yes <input checked="" type="checkbox"/> No
If Yes:	
<i>i.</i> Identify the name of the river and its designation: _____	
<i>ii.</i> Is the activity consistent with development restrictions contained in 6NYCRR Part 666?	
<input type="checkbox"/> Yes <input checked="" type="checkbox"/> No	

F. Additional Information

Attach any additional information which may be needed to clarify your project.

If you have identified any adverse impacts which could be associated with your proposal, please describe those impacts plus any measures which you propose to avoid or minimize them.

G. Verification

I certify that the information provided is true to the best of my knowledge.

Applicant/Sponsor Name Thomas Richards

Date 12/23/2003

Signature 

Title Mayor, City of Rochester

PRINT FORM

RESET FORM

Attachment #1

The Inner Loop East Reconstruction Project consists of the removal of an urban expressway known as the "Inner Loop" through the SE quadrant of the City of Rochester downtown area. The conceptual project originated in the early 1990's and has been a part of the City of Rochester's comprehensive plan ever since. The project will remove excess highway infrastructure (replacing the existing 10 - 12 lane section with a 3 - 5 lane section) from Clinton Street South to East Main Street and provide a "complete Street" facility that is properly scaled to the regional and local needs. The "complete street" design approach incorporates balanced pedestrian, bicycle and vehicle needs throughout the project corridor. Approximately 120,000 cubic yards of clean fill will need to be imported to bring the project site up to the needed grade. Fill material will come from other City of Rochester project sites, as well as from other private and public projects as needed.

The project will incorporate innovative design concepts for pedestrian and bicyclist including a cycle track that will provide cyclists with their own designated travel way separated from vehicular traffic. The proposed roadway would be constructed along the existing street alignments (Union, Howell and Pitkin Streets) and reestablish the original street grid network that provided connectivity between the adjoining neighborhoods and downtown that existed prior to the urbanization and construction of the expressway. As a secondary benefit, the removal of the excess highway infrastructure will provide the City with a unique opportunity to create additional land that could be developed within the downtown area. This potential development would be progressed in the future by the City of Rochester to fit the vision and character of the surrounding neighborhoods.

As part of the Real Estate Market Analysis Report, it was estimated that the land created by the Project could support between 428,000 and 795,000 square feet (SF) of development. The most intensive development scenario envisioned for the Project includes 795,062 SF, which includes 625 residential units. Approximately ten (10) parcels would be created to accommodate this development over time.

Attachment #2

Other local agencies that need to approve, fund or sponsor the Project include:

- Mayor, City of Rochester – same as "a" above;
- Director of Planning and Zoning – Site Plan Approval;
- Commissioner of Neighborhood & Business Development – Site Preparation permit;
- TCB – approval of pavement width changes, parking changes, etc.

Attachment #3

The multi-faceted Project includes the following physical and legal components. Please note that some of these components will occur sequentially, while others will progress concurrently over time.

- 1) Right of Way (ROW) abandonment and transfer to from NYSDOT to City of Rochester;
- 2) Rebuild the adjacent roads (Howell, Union and Pitkin Streets);
- 3) Demolish the existing Inner Loop;
- 4) Filling of the Inner Loop to the needed grade. Approximately 120,000 cubic yards of clean fill needed to be brought on-site;
- 5) Obtain "Official Map Amendment" (OMA) to establish the new ROW;
- 6) Subdivision of non-ROW needed land to create new parcels;
- 7) Development of the newly created parcels.

Approximately three (3) years are needed to complete the first six (6) components, from start to finish. The development of the new parcels will be by private developers and subject to market conditions, funding, etc.

Attachment #4

Attachment #4, "Cultural Resource Study – Inner Loop East Reconstruction Project" is provided under separate cover. The CRS contains a Phase 1A Cultural Resources Survey and a Phase 1B Archaeological and Architectural Survey of the project area.

Two historic archaeological sites have been identified, however, no further archaeological work was recommended for the Project, save for the construction monitoring to mitigate the effects unanticipated impacts or discoveries at two locations. The two sites were designated George Crouch (A05540.009184, UB 4409) site and the Amos Burrows (AO5540.009185, UB 4410) site.

Please see pages 35-59 of the Phase 1B Archaeological and Architectural Reconnaissance Survey for descriptions of the attributes for three National Register Listed (NRL) properties, four National register eligible (NRE) properties, two NRE Historic Districts, and three non-NRE properties associated with the project area.

Full Environmental Assessment Form
Part 2 - Identification of Potential Project Impacts

Part 2 is to be completed by the lead agency. Part 2 is designed to help the lead agency inventory all potential resources that could be affected by a proposed project or action. We recognize that the lead agency's reviewer(s) will not necessarily be environmental professionals. So, the questions are designed to walk a reviewer through the assessment process by providing a series of questions that can be answered using the information found in Part 1. To further assist the lead agency in completing Part 2, the form identifies the most relevant questions in Part 1 that will provide the information needed to answer the Part 2 question. When Part 2 is completed, the lead agency will have identified the relevant environmental areas that may be impacted by the proposed activity.

If the lead agency is a state agency and the action is in any Coastal Area, complete the Coastal Assessment Form before proceeding with this assessment.

Tips for completing Part 2:

- Review all of the information provided in Part 1.
- Review any application, maps, supporting materials and the Full EAF Workbook.
- Answer each of the 18 questions in Part 2.
- If you answer "Yes" to a numbered question, please complete all the questions that follow in that section.
- If you answer "No" to a numbered question, move on to the next numbered question.
- Check appropriate column to indicate the anticipated size of the impact.
- Proposed projects that would exceed a numeric threshold contained in a question should result in the reviewing agency checking the box "Moderate to large impact may occur."
- The reviewer is not expected to be an expert in environmental analysis.
- If you are not sure or undecided about the size of an impact, it may help to review the sub-questions for the general question and consult the workbook.
- When answering a question consider all components of the proposed activity, that is, the "whole action".
- Consider the possibility for long-term and cumulative impacts as well as direct impacts.
- Answer the question in a reasonable manner considering the scale and context of the project.

1. Impact on Land Proposed action may involve construction on, or physical alteration of, the land surface of the proposed site. (See Part 1. D.1) <input type="checkbox"/> NO <input checked="" type="checkbox"/> YES <i>If "Yes", answer questions a - j. If "No", move on to Section 2.</i>			
	Relevant Part I Question(s)	No, or small impact may occur	Moderate to large impact may occur
a. The proposed action may involve construction on land where depth to water table is less than 3 feet.	E2d	<input checked="" type="checkbox"/>	<input type="checkbox"/>
b. The proposed action may involve construction on slopes of 15% or greater.	E2f	<input checked="" type="checkbox"/>	<input type="checkbox"/>
c. The proposed action may involve construction on land where bedrock is exposed, or generally within 5 feet of existing ground surface.	E2a	<input checked="" type="checkbox"/>	<input type="checkbox"/>
d. The proposed action may involve the excavation and removal of more than 1,000 tons of natural material.	D2a	<input checked="" type="checkbox"/>	<input type="checkbox"/>
e. The proposed action may involve construction that continues for more than one year or in multiple phases.	D1e	<input type="checkbox"/>	<input checked="" type="checkbox"/>
f. The proposed action may result in increased erosion, whether from physical disturbance or vegetation removal (including from treatment by herbicides).	D2e, D2q	<input checked="" type="checkbox"/>	<input type="checkbox"/>
g. The proposed action is, or may be, located within a Coastal Erosion hazard area.	B1i	<input checked="" type="checkbox"/>	<input type="checkbox"/>
h. Other impacts: <u>Impacts from future development parcels, importing of needed fill, and stormwater and utilities.</u>		<input type="checkbox"/>	<input checked="" type="checkbox"/>

2. Impact on Geological Features
 The proposed action may result in the modification or destruction of, or inhibit access to, any unique or unusual land forms on the site (e.g., cliffs, dunes, minerals, fossils, caves). (See Part 1, E.2.g) NO YES
If "Yes", answer questions a - c. If "No", move on to Section 3.

	Relevant Part I Question(s)	No, or small impact may occur	Moderate to large impact may occur
a. Identify the specific land form(s) attached: _____ _____	E2g	<input type="checkbox"/>	<input type="checkbox"/>
b. The proposed action may affect or is adjacent to a geological feature listed as a registered National Natural Landmark. Specific feature: _____	E3c	<input type="checkbox"/>	<input type="checkbox"/>
c. Other impacts: _____ _____		<input type="checkbox"/>	<input type="checkbox"/>

3. Impacts on Surface Water
 The proposed action may affect one or more wetlands or other surface water bodies (e.g., streams, rivers, ponds or lakes). (See Part 1, D.2, E.2.h) NO YES
If "Yes", answer questions a - l. If "No", move on to Section 4.

	Relevant Part I Question(s)	No, or small impact may occur	Moderate to large impact may occur
a. The proposed action may create a new water body.	D2b, D1h	<input type="checkbox"/>	<input type="checkbox"/>
b. The proposed action may result in an increase or decrease of over 10% or more than a 10 acre increase or decrease in the surface area of any body of water.	D2b	<input type="checkbox"/>	<input type="checkbox"/>
c. The proposed action may involve dredging more than 100 cubic yards of material from a wetland or water body.	D2a	<input type="checkbox"/>	<input type="checkbox"/>
d. The proposed action may involve construction within or adjoining a freshwater or tidal wetland, or in the bed or banks of any other water body.	E2h	<input type="checkbox"/>	<input type="checkbox"/>
e. The proposed action may create turbidity in a waterbody, either from upland erosion, runoff or by disturbing bottom sediments.	D2a, D2h	<input type="checkbox"/>	<input type="checkbox"/>
f. The proposed action may include construction of one or more intake(s) for withdrawal of water from surface water.	D2c	<input type="checkbox"/>	<input type="checkbox"/>
g. The proposed action may include construction of one or more outfall(s) for discharge of wastewater to surface water(s).	D2d	<input type="checkbox"/>	<input type="checkbox"/>
h. The proposed action may cause soil erosion, or otherwise create a source of stormwater discharge that may lead to siltation or other degradation of receiving water bodies.	D2e	<input type="checkbox"/>	<input type="checkbox"/>
i. The proposed action may affect the water quality of any water bodies within or downstream of the site of the proposed action.	E2h	<input type="checkbox"/>	<input type="checkbox"/>
j. The proposed action may involve the application of pesticides or herbicides in or around any water body.	D2q, E2h	<input type="checkbox"/>	<input type="checkbox"/>
k. The proposed action may require the construction of new, or expansion of existing, wastewater treatment facilities.	D1a, D2d	<input type="checkbox"/>	<input type="checkbox"/>

l. Other impacts: _____ _____		<input type="checkbox"/>	<input type="checkbox"/>
----------------------------------	--	--------------------------	--------------------------

4. Impact on groundwater The proposed action may result in new or additional use of ground water, or may have the potential to introduce contaminants to ground water or an aquifer. (See Part 1. D.2.a, D.2.c, D.2.d, D.2.p, D.2.q, D.2.t) <i>If "Yes", answer questions a - h. If "No", move on to Section 5.</i>			
		<input checked="" type="checkbox"/> NO	<input type="checkbox"/> YES
	Relevant Part I Question(s)	No, or small impact may occur	Moderate to large impact may occur
a. The proposed action may require new water supply wells, or create additional demand on supplies from existing water supply wells.	D2c	<input type="checkbox"/>	<input type="checkbox"/>
b. Water supply demand from the proposed action may exceed safe and sustainable withdrawal capacity rate of the local supply or aquifer. Cite Source: _____	D2c	<input type="checkbox"/>	<input type="checkbox"/>
c. The proposed action may allow or result in residential uses in areas without water and sewer services.	D1a, D2c	<input type="checkbox"/>	<input type="checkbox"/>
d. The proposed action may include or require wastewater discharged to groundwater.	D2d, E2l	<input type="checkbox"/>	<input type="checkbox"/>
e. The proposed action may result in the construction of water supply wells in locations where groundwater is, or is suspected to be, contaminated.	D2c, E1f, E1g, E1h	<input type="checkbox"/>	<input type="checkbox"/>
f. The proposed action may require the bulk storage of petroleum or chemical products over ground water or an aquifer.	D2p, E2l	<input type="checkbox"/>	<input type="checkbox"/>
g. The proposed action may involve the commercial application of pesticides within 100 feet of potable drinking water or irrigation sources.	E2h, D2q, E2l, D2c	<input type="checkbox"/>	<input type="checkbox"/>
h. Other impacts: _____ _____		<input type="checkbox"/>	<input type="checkbox"/>

5. Impact on Flooding The proposed action may result in development on lands subject to flooding. (See Part 1. E.2) <i>If "Yes", answer questions a - g. If "No", move on to Section 6.</i>			
		<input checked="" type="checkbox"/> NO	<input type="checkbox"/> YES
	Relevant Part I Question(s)	No, or small impact may occur	Moderate to large impact may occur
a. The proposed action may result in development in a designated floodway.	E2i	<input type="checkbox"/>	<input type="checkbox"/>
b. The proposed action may result in development within a 100 year floodplain.	E2j	<input type="checkbox"/>	<input type="checkbox"/>
c. The proposed action may result in development within a 500 year floodplain.	E2k	<input type="checkbox"/>	<input type="checkbox"/>
d. The proposed action may result in, or require, modification of existing drainage patterns.	D2b, D2e	<input type="checkbox"/>	<input type="checkbox"/>
e. The proposed action may change flood water flows that contribute to flooding.	D2b, E2i, E2j, E2k	<input type="checkbox"/>	<input type="checkbox"/>
f. If there is a dam located on the site of the proposed action, is the dam in need of repair or upgrade?	E1e	<input type="checkbox"/>	<input type="checkbox"/>

g. Other impacts: _____ _____		<input type="checkbox"/>	<input type="checkbox"/>
----------------------------------	--	--------------------------	--------------------------

6. Impacts on Air The proposed action may include a state regulated air emission source. <input checked="" type="checkbox"/> NO <input type="checkbox"/> YES (See Part 1. D.2.f., D.2.h, D.2.g) <i>If "Yes", answer questions a - f. If "No", move on to Section 7.</i>			
	Relevant Part I Question(s)	No, or small impact may occur	Moderate to large impact may occur
a. If the proposed action requires federal or state air emission permits, the action may also emit one or more greenhouse gases at or above the following levels:			
i. More than 1000 tons/year of carbon dioxide (CO ₂)	D2g	<input type="checkbox"/>	<input type="checkbox"/>
ii. More than 3.5 tons/year of nitrous oxide (N ₂ O)	D2g	<input type="checkbox"/>	<input type="checkbox"/>
iii. More than 1000 tons/year of carbon equivalent of perfluorocarbons (PFCs)	D2g	<input type="checkbox"/>	<input type="checkbox"/>
iv. More than .045 tons/year of sulfur hexafluoride (SF ₆)	D2g	<input type="checkbox"/>	<input type="checkbox"/>
v. More than 1000 tons/year of carbon dioxide equivalent of hydrochloroflourocarbons (HFCs) emissions	D2g	<input type="checkbox"/>	<input type="checkbox"/>
vi. 43 tons/year or more of methane	D2h	<input type="checkbox"/>	<input type="checkbox"/>
b. The proposed action may generate 10 tons/year or more of any one designated hazardous air pollutant, or 25 tons/year or more of any combination of such hazardous air pollutants.	D2g	<input type="checkbox"/>	<input type="checkbox"/>
c. The proposed action may require a state air registration, or may produce an emissions rate of total contaminants that may exceed 5 lbs. per hour, or may include a heat source capable of producing more than 10 million BTU's per hour.	D2f, D2g	<input type="checkbox"/>	<input type="checkbox"/>
d. The proposed action may reach 50% of any of the thresholds in "a" through "c", above.	D2g	<input type="checkbox"/>	<input type="checkbox"/>
e. The proposed action may result in the combustion or thermal treatment of more than 1 ton of refuse per hour.	D2s	<input type="checkbox"/>	<input type="checkbox"/>
f. Other impacts: _____ _____		<input type="checkbox"/>	<input type="checkbox"/>

7. Impact on Plants and Animals The proposed action may result in a loss of flora or fauna. (See Part 1. E.2. m.-q.) <input checked="" type="checkbox"/> NO <input type="checkbox"/> YES <i>If "Yes", answer questions a - j. If "No", move on to Section 8.</i>			
	Relevant Part I Question(s)	No, or small impact may occur	Moderate to large impact may occur
a. The proposed action may cause reduction in population or loss of individuals of any threatened or endangered species, as listed by New York State or the Federal government, that use the site, or are found on, over, or near the site.	E2o	<input type="checkbox"/>	<input type="checkbox"/>
b. The proposed action may result in a reduction or degradation of any habitat used by any rare, threatened or endangered species, as listed by New York State or the federal government.	E2o	<input type="checkbox"/>	<input type="checkbox"/>
c. The proposed action may cause reduction in population, or loss of individuals, of any species of special concern or conservation need, as listed by New York State or the Federal government, that use the site, or are found on, over, or near the site.	E2p	<input type="checkbox"/>	<input type="checkbox"/>
d. The proposed action may result in a reduction or degradation of any habitat used by any species of special concern and conservation need, as listed by New York State or the Federal government.	E2p	<input type="checkbox"/>	<input type="checkbox"/>

e. The proposed action may diminish the capacity of a registered National Natural Landmark to support the biological community it was established to protect.	E3c	<input type="checkbox"/>	<input type="checkbox"/>
f. The proposed action may result in the removal of, or ground disturbance in, any portion of a designated significant natural community. Source: _____	E2n	<input type="checkbox"/>	<input type="checkbox"/>
g. The proposed action may substantially interfere with nesting/breeding, foraging, or over-wintering habitat for the predominant species that occupy or use the project site.	E2m	<input type="checkbox"/>	<input type="checkbox"/>
h. The proposed action requires the conversion of more than 10 acres of forest, grassland or any other regionally or locally important habitat. Habitat type & information source: _____	E1b	<input type="checkbox"/>	<input type="checkbox"/>
i. Proposed action (commercial, industrial or recreational projects, only) involves use of herbicides or pesticides.	D2q	<input type="checkbox"/>	<input type="checkbox"/>
j. Other impacts: _____		<input type="checkbox"/>	<input type="checkbox"/>

8. Impact on Agricultural Resources			
The proposed action may impact agricultural resources. (See Part I. E.3.a. and b.)		<input checked="" type="checkbox"/> NO	<input type="checkbox"/> YES
<i>If "Yes", answer questions a - h. If "No", move on to Section 9.</i>			
	Relevant Part I Question(s)	No, or small impact may occur	Moderate to large impact may occur
a. The proposed action may impact soil classified within soil group 1 through 4 of the NYS Land Classification System.	E2c, E3b	<input type="checkbox"/>	<input type="checkbox"/>
b. The proposed action may sever, cross or otherwise limit access to agricultural land (includes cropland, hayfields, pasture, vineyard, orchard, etc).	E1a, E1b	<input type="checkbox"/>	<input type="checkbox"/>
c. The proposed action may result in the excavation or compaction of the soil profile of active agricultural land.	E3b	<input type="checkbox"/>	<input type="checkbox"/>
d. The proposed action may irreversibly convert agricultural land to non-agricultural uses, either more than 2.5 acres if located in an Agricultural District, or more than 10 acres if not within an Agricultural District.	E1b, E3a	<input type="checkbox"/>	<input type="checkbox"/>
e. The proposed action may disrupt or prevent installation of an agricultural land management system.	E1 a, E1b	<input type="checkbox"/>	<input type="checkbox"/>
f. The proposed action may result, directly or indirectly, in increased development potential or pressure on farmland.	C2c, C3, D2c, D2d	<input type="checkbox"/>	<input type="checkbox"/>
g. The proposed project is not consistent with the adopted municipal Farmland Protection Plan.	C2c	<input type="checkbox"/>	<input type="checkbox"/>
h. Other impacts: _____		<input type="checkbox"/>	<input type="checkbox"/>

9. Impact on Aesthetic Resources The land use of the proposed action are obviously different from, or are in sharp contrast to, current land use patterns between the proposed project and a scenic or aesthetic resource. (Part I. E.1.a, E.1.b, E.3.h.) <i>If "Yes", answer questions a - g. If "No", go to Section 10.</i>			
		<input checked="" type="checkbox"/> NO	<input type="checkbox"/> YES
	Relevant Part I Question(s)	No, or small impact may occur	Moderate to large impact may occur
a. Proposed action may be visible from any officially designated federal, state, or local scenic or aesthetic resource.	E3h	<input type="checkbox"/>	<input type="checkbox"/>
b. The proposed action may result in the obstruction, elimination or significant screening of one or more officially designated scenic views.	E3h, C2b	<input type="checkbox"/>	<input type="checkbox"/>
c. The proposed action may be visible from publicly accessible vantage points: i. Seasonally (e.g., screened by summer foliage, but visible during other seasons) ii. Year round	E3h	<input type="checkbox"/> <input type="checkbox"/>	<input type="checkbox"/> <input type="checkbox"/>
d. The situation or activity in which viewers are engaged while viewing the proposed action is: i. Routine travel by residents, including travel to and from work ii. Recreational or tourism based activities	E3h E2q, E1c	<input type="checkbox"/> <input type="checkbox"/>	<input type="checkbox"/> <input type="checkbox"/>
e. The proposed action may cause a diminishment of the public enjoyment and appreciation of the designated aesthetic resource.	E3h	<input type="checkbox"/>	<input type="checkbox"/>
f. There are similar projects visible within the following distance of the proposed project: 0-1/2 mile 1/2-3 mile 3-5 mile 5+ mile	D1a, E1a, D1f, D1g	<input type="checkbox"/>	<input type="checkbox"/>
g. Other impacts: _____ _____		<input type="checkbox"/>	<input type="checkbox"/>

10. Impact on Historic and Archeological Resources The proposed action may occur in or adjacent to a historic or archaeological resource. (Part I. E.3.e, f. and g.) <i>If "Yes", answer questions a - e. If "No", go to Section 11.</i>			
		<input type="checkbox"/> NO	<input checked="" type="checkbox"/> YES
	Relevant Part I Question(s)	No, or small impact may occur	Moderate to large impact may occur
a. The proposed action may occur wholly or partially within, or substantially contiguous to, any buildings, archaeological site or district which is listed on or has been nominated by the NYS Board of Historic Preservation for inclusion on the State or National Register of Historic Places.	E3e	<input checked="" type="checkbox"/>	<input type="checkbox"/>
b. The proposed action may occur wholly or partially within, or substantially contiguous to, an area designated as sensitive for archaeological sites on the NY State Historic Preservation Office (SHPO) archaeological site inventory.	E3f	<input checked="" type="checkbox"/>	<input type="checkbox"/>
c. The proposed action may occur wholly or partially within, or substantially contiguous to, an archaeological site not included on the NY SHPO inventory. Source: _____	E3g	<input checked="" type="checkbox"/>	<input type="checkbox"/>

d. Other impacts: Presence of two (2) historic archeological sites. Both appear to be National Register eligible		<input type="checkbox"/>	<input checked="" type="checkbox"/>
e. If any of the above (a-d) are answered "Yes", continue with the following questions to help support conclusions in Part 3:			
i. The proposed action may result in the destruction or alteration of all or part of the site or property.	E3e, E3g, E3f	<input checked="" type="checkbox"/>	<input type="checkbox"/>
ii. The proposed action may result in the alteration of the property's setting or integrity.	E3e, E3f, E3g, E1a, E1b	<input checked="" type="checkbox"/>	<input type="checkbox"/>
iii. The proposed action may result in the introduction of visual elements which are out of character with the site or property, or may alter its setting.	E3e, E3f, E3g, E3h, C2, C3	<input checked="" type="checkbox"/>	<input type="checkbox"/>

11. Impact on Open Space and Recreation

The proposed action may result in a loss of recreational opportunities or a reduction of an open space resource as designated in any adopted municipal open space plan. NO YES

(See Part 1. C.2.c. E.1.e., E.2.q.)
If "Yes", answer questions a - e. If "No", go to Section 12.

	Relevant Part I Question(s)	No, or small impact may occur	Moderate to large impact may occur
a. The proposed action may result in an impairment of natural functions, or "ecosystem services", provided by an undeveloped area, including but not limited to stormwater storage, nutrient cycling, wildlife habitat.	D2e, E1b, E2h, E2m, E2o, E2n, E2p	<input type="checkbox"/>	<input type="checkbox"/>
b. The proposed action may result in the loss of a current or future recreational resource.	C2a, E1c, C2c, E2q	<input type="checkbox"/>	<input type="checkbox"/>
c. The proposed action may eliminate open space or recreational resource in an area with few such resources.	C2a, C2c, E1c, E2q	<input type="checkbox"/>	<input type="checkbox"/>
d. The proposed action may result in loss of an area now used informally by the community as an open space resource.	C2c, E1c	<input type="checkbox"/>	<input type="checkbox"/>
e. Other impacts: _____		<input type="checkbox"/>	<input type="checkbox"/>

12. Impact on Critical Environmental Areas

The proposed action may be located within or adjacent to a critical environmental area (CEA). (See Part 1. E.3.d) NO YES

If "Yes", answer questions a - c. If "No", go to Section 13.

	Relevant Part I Question(s)	No, or small impact may occur	Moderate to large impact may occur
a. The proposed action may result in a reduction in the quantity of the resource or characteristic which was the basis for designation of the CEA.	E3d	<input type="checkbox"/>	<input type="checkbox"/>
b. The proposed action may result in a reduction in the quality of the resource or characteristic which was the basis for designation of the CEA.	E3d	<input type="checkbox"/>	<input type="checkbox"/>
c. Other impacts: _____		<input type="checkbox"/>	<input type="checkbox"/>

13. Impact on Transportation
 The proposed action may result in a change to existing transportation systems. NO YES
 (See Part 1. D.2.j)
If "Yes", answer questions a - g. If "No", go to Section 14.

	Relevant Part I Question(s)	No, or small impact may occur	Moderate to large impact may occur
a. Projected traffic increase may exceed capacity of existing road network.	D2j	<input checked="" type="checkbox"/>	<input type="checkbox"/>
b. The proposed action may result in the construction of paved parking area for 500 or more vehicles.	D2j	<input checked="" type="checkbox"/>	<input type="checkbox"/>
c. The proposed action will degrade existing transit access.	D2j	<input checked="" type="checkbox"/>	<input type="checkbox"/>
d. The proposed action will degrade existing pedestrian or bicycle accommodations.	D2j	<input checked="" type="checkbox"/>	<input type="checkbox"/>
e. The proposed action may alter the present pattern of movement of people or goods.	D2j	<input type="checkbox"/>	<input checked="" type="checkbox"/>
f. Other impacts: _____ _____		<input type="checkbox"/>	<input type="checkbox"/>

14. Impact on Energy
 The proposed action may cause an increase in the use of any form of energy. NO YES
 (See Part 1. D.2.k)
If "Yes", answer questions a - e. If "No", go to Section 15.

	Relevant Part I Question(s)	No, or small impact may occur	Moderate to large impact may occur
a. The proposed action will require a new, or an upgrade to an existing, substation.	D2k	<input checked="" type="checkbox"/>	<input type="checkbox"/>
b. The proposed action will require the creation or extension of an energy transmission or supply system to serve more than 50 single or two-family residences or to serve a commercial or industrial use.	D1f, D1q, D2k	<input checked="" type="checkbox"/>	<input type="checkbox"/>
c. The proposed action may utilize more than 2,500 MWhrs per year of electricity.	D2k	<input checked="" type="checkbox"/>	<input type="checkbox"/>
d. The proposed action may involve heating and/or cooling of more than 100,000 square feet of building area when completed.	D1g	<input type="checkbox"/>	<input checked="" type="checkbox"/>
e. Other Impacts: _____ _____		<input type="checkbox"/>	<input type="checkbox"/>

15. Impact on Noise, Odor, and Light
 The proposed action may result in an increase in noise, odors, or outdoor lighting. NO YES
 (See Part 1. D.2.m., n., and o.)
If "Yes", answer questions a - f. If "No", go to Section 16.

	Relevant Part I Question(s)	No, or small impact may occur	Moderate to large impact may occur
a. The proposed action may produce sound above noise levels established by local regulation.	D2m	<input type="checkbox"/>	<input type="checkbox"/>
b. The proposed action may result in blasting within 1,500 feet of any residence, hospital, school, licensed day care center, or nursing home.	D2m, E1d	<input type="checkbox"/>	<input type="checkbox"/>
c. The proposed action may result in routine odors for more than one hour per day.	D2o	<input type="checkbox"/>	<input type="checkbox"/>

d. The proposed action may result in light shining onto adjoining properties.	D2n	<input type="checkbox"/>	<input type="checkbox"/>
e. The proposed action may result in lighting creating sky-glow brighter than existing area conditions.	D2n, E1a	<input type="checkbox"/>	<input type="checkbox"/>
f. Other impacts: _____ _____		<input type="checkbox"/>	<input type="checkbox"/>

16. Impact on Human Health The proposed action may have an impact on human health from exposure to new or existing sources of contaminants. (See Part 1.D.2.q., E.1. d. f. g. and h.) <input checked="" type="checkbox"/> NO <input type="checkbox"/> YES <i>If "Yes", answer questions a - m. If "No", go to Section 17.</i>			
	Relevant Part I Question(s)	No, or small impact may occur	Moderate to large impact may occur
a. The proposed action is located within 1500 feet of a school, hospital, licensed day care center, group home, nursing home or retirement community.	E1d	<input type="checkbox"/>	<input type="checkbox"/>
b. The site of the proposed action is currently undergoing remediation.	E1g, E1h	<input type="checkbox"/>	<input type="checkbox"/>
c. There is a completed emergency spill remediation, or a completed environmental site remediation on, or adjacent to, the site of the proposed action.	E1g, E1h	<input type="checkbox"/>	<input type="checkbox"/>
d. The site of the action is subject to an institutional control limiting the use of the property (e.g., easement or deed restriction).	E1g, E1h	<input type="checkbox"/>	<input type="checkbox"/>
e. The proposed action may affect institutional control measures that were put in place to ensure that the site remains protective of the environment and human health.	E1g, E1h	<input type="checkbox"/>	<input type="checkbox"/>
f. The proposed action has adequate control measures in place to ensure that future generation, treatment and/or disposal of hazardous wastes will be protective of the environment and human health.	D2t	<input type="checkbox"/>	<input type="checkbox"/>
g. The proposed action involves construction or modification of a solid waste management facility.	D2q, E1f	<input type="checkbox"/>	<input type="checkbox"/>
h. The proposed action may result in the unearthing of solid or hazardous waste.	D2q, E1f	<input type="checkbox"/>	<input type="checkbox"/>
i. The proposed action may result in an increase in the rate of disposal, or processing, of solid waste.	D2r, D2s	<input type="checkbox"/>	<input type="checkbox"/>
j. The proposed action may result in excavation or other disturbance within 2000 feet of a site used for the disposal of solid or hazardous waste.	E1f, E1g E1h	<input type="checkbox"/>	<input type="checkbox"/>
k. The proposed action may result in the migration of explosive gases from a landfill site to adjacent off site structures.	E1f, E1g	<input type="checkbox"/>	<input type="checkbox"/>
l. The proposed action may result in the release of contaminated leachate from the project site.	D2s, E1f, D2r	<input type="checkbox"/>	<input type="checkbox"/>
m. Other impacts: _____ _____			

17. Consistency with Community Plans The proposed action is not consistent with adopted land use plans. (See Part I. C.1, C.2, and C.3.) <i>If "Yes", answer questions a - h. If "No", go to Section 18.</i>				<input checked="" type="checkbox"/> NO	<input type="checkbox"/> YES
	Relevant Part I Question(s)	No, or small impact may occur	Moderate to large impact may occur		
a. The proposed action's land use components may be different from, or in sharp contrast to, current surrounding land use pattern(s).	C2, C3, D1a E1a, E1b	<input type="checkbox"/>	<input type="checkbox"/>		
b. The proposed action will cause the permanent population of the city, town or village in which the project is located to grow by more than 5%.	C2	<input type="checkbox"/>	<input type="checkbox"/>		
c. The proposed action is inconsistent with local land use plans or zoning regulations.	C2, C2, C3	<input type="checkbox"/>	<input type="checkbox"/>		
d. The proposed action is inconsistent with any County plans, or other regional land use plans.	C2, C2	<input type="checkbox"/>	<input type="checkbox"/>		
e. The proposed action may cause a change in the density of development that is not supported by existing infrastructure or is distant from existing infrastructure.	C3, D1e, D1d, D1f, D1d, E1b	<input type="checkbox"/>	<input type="checkbox"/>		
f. The proposed action is located in an area characterized by low density development that will require new or expanded public infrastructure.	C4, D2c, D2d D2j	<input type="checkbox"/>	<input type="checkbox"/>		
g. The proposed action may induce secondary development impacts (e.g., residential or commercial development not included in the proposed action)	C2a	<input type="checkbox"/>	<input type="checkbox"/>		
h. Other: _____ _____		<input type="checkbox"/>	<input type="checkbox"/>		

18. Consistency with Community Character The proposed project is inconsistent with the existing community character. (See Part I. C.2, C.3, D.2, E.3) <i>If "Yes", answer questions a - g. If "No", proceed to Part 3.</i>				<input checked="" type="checkbox"/> NO	<input type="checkbox"/> YES
	Relevant Part I Question(s)	No, or small impact may occur	Moderate to large impact may occur		
a. The proposed action may replace or eliminate existing facilities, structures, or areas of historic importance to the community.	E3e, E3f, E3g	<input type="checkbox"/>	<input type="checkbox"/>		
b. The proposed action may create a demand for additional community services (e.g. schools, police and fire)	C4	<input type="checkbox"/>	<input type="checkbox"/>		
c. The proposed action may displace affordable or low-income housing in an area where there is a shortage of such housing.	C2, C3, D1f D1g, E1a	<input type="checkbox"/>	<input type="checkbox"/>		
d. The proposed action may interfere with the use or enjoyment of officially recognized or designated public resources.	C2, E3	<input type="checkbox"/>	<input type="checkbox"/>		
e. The proposed action is inconsistent with the predominant architectural scale and character.	C2, C3	<input type="checkbox"/>	<input type="checkbox"/>		
f. Proposed action is inconsistent with the character of the existing natural landscape.	C2, C3 E1a, E1b E2g, E2h	<input type="checkbox"/>	<input type="checkbox"/>		
g. Other impacts: _____ _____		<input type="checkbox"/>	<input type="checkbox"/>		

Full Environmental Assessment Form
Part 3 - Evaluation of the Magnitude and Importance of Project Impacts
and
Determination of Significance

Part 3 provides the reasons in support of the determination of significance. The lead agency must complete Part 3 for every question in Part 2 where the impact has been identified as potentially moderate to large or where there is a need to explain why a particular element of the proposed action will not, or may, result in a significant adverse environmental impact.

Based on the analysis in Part 3, the lead agency must decide whether to require an environmental impact statement to further assess the proposed action or whether available information is sufficient for the lead agency to conclude that the proposed action will not have a significant adverse environmental impact. By completing the certification on the next page, the lead agency can complete its determination of significance.

Reasons Supporting This Determination:

To complete this section:

- Identify the impact based on the Part 2 responses and describe its magnitude. Magnitude considers factors such as severity, size or extent of an impact.
- Assess the importance of the impact. Importance relates to the geographic scope, duration, probability of the impact occurring, number of people affected by the impact and any additional environmental consequences if the impact were to occur.
- The assessment should take into consideration any design element or project changes.
- Repeat this process for each Part 2 question where the impact has been identified as potentially moderate to large or where there is a need to explain why a particular element of the proposed action will not, or may, result in a significant adverse environmental impact.
- Provide the reason(s) why the impact may, or will not, result in a significant adverse environmental impact
- For Conditional Negative Declarations identify the specific condition(s) imposed that will modify the proposed action so that no significant adverse environmental impacts will result.
- Attach additional sheets, as needed.

Determination of Significance - Type 1 and Unlisted Actions

SEQR Status: Type 1 Unlisted

Identify portions of EAF completed for this Project: Part 1 Part 2 Part 3

Upon review of the information recorded on this EAF, as noted, plus this additional support information
Various supplemental studies and assessments, including a Noise Analysis, Air Quality Analysis, Hazardous Waste Assessment, Asbestos Assessment, Cultural Resource Investigation, Visual Impact Assessment, Traffic Study, and the NEPA Environmental Assessment (EA).

and considering both the magnitude and importance of each identified potential impact, it is the conclusion of the
Mayor, City of Rochester _____ as lead agency that:

A. This project will result in no significant adverse impacts on the environment, and, therefore, an environmental impact statement need not be prepared. Accordingly, this negative declaration is issued.

B. Although this project could have a significant adverse impact on the environment, that impact will be avoided or substantially mitigated because of the following conditions which will be required by the lead agency:

There will, therefore, be no significant adverse impacts from the project as conditioned, and, therefore, this conditioned negative declaration is issued. A conditioned negative declaration may be used only for UNLISTED actions (see 6 NYCRR 617.d).

C. This Project may result in one or more significant adverse impacts on the environment, and an environmental impact statement must be prepared to further assess the impact(s) and possible mitigation and to explore alternatives to avoid or reduce those impacts. Accordingly, this positive declaration is issued.

Name of Action: Inner Loop East Reconstruction Project

Name of Lead Agency: City of Rochester

Name of Responsible Officer in Lead Agency: Mayor Thomas S. Richards

Title of Responsible Officer: Mayor

Signature of Responsible Officer in Lead Agency: 

Date: 12/23/2013

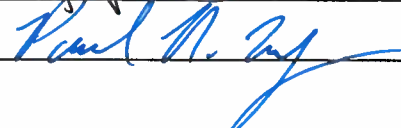
Signature of Preparer (if different from Responsible Officer) 

Date: 12-23-2013

For Further Information:

Contact Person: Mr. James R. McIntosh, P.E., City Engineer
Address: City Hall, Room 300B, 30 Church Street, Rochester, NY 14614
Telephone Number: 585-428-6828
E-mail: Jim.McIntosh@cityofrochester.gov

For Type I Actions and Conditioned Negative Declarations, a copy of this Notice is sent to:

Chief Executive Officer of the political subdivision in which the action will be principally located (e.g., Town / City / Village of)
Other involved agencies (if any)
Applicant (if any)
Environmental Notice Bulletin: <http://www.dec.ny.gov/enb/enb.html>

EAF Part 3 – Evaluation of the Magnitude and Importance of Project Impacts

And

Determination of Significance

In completing Part 2 of the Environmental Assessment Form for the proposed Inner Loop East Reconstruction Project (Project), information and results from the following reports and studies were used in the identification of potential project impacts:

- Cultural Resources Study (Dept. of Anthropology, State University of New York)
- Noise Analysis Report (Watts Architecture and Engineering);
- Air Quality Analysis Report (Watts Architecture and Engineering);
- Hazardous Waste/Contaminated Materials Assessment (Watts Engineering and Architecture);
- Asbestos Assessment (Watts Engineering and Architecture);
- Visual Impact Assessment (Stantec Consulting Ltd.);
- Traffic Study (Stantec Consulting Ltd.) and
- Social, Economic and Environmental Conditions and Consequences (NEPA Environmental Assessment prepared by Stantec Consulting Ltd.)

Part 3 of the EAF evaluates every question in Part 2 where the impact has been identified as potentially moderate to large or where there is a need to explain why a particular element of the proposed action will, or may, result in a significant adverse environmental impact. The following potential impacts were identified as potentially moderate to large and are evaluated further.

Impact on Land

The Inner Loop East Reconstruction Project will physically change the grade of the existing land surface within the proposed 24.6 acre project corridor. The project consists of the removal of an urban expressway known as the "Inner Loop" through the SE quadrant of the City of Rochester downtown area. The project will remove excess highway infrastructure (replacing the existing 10 - 12 lane section with a 3 - 5 lane section) from Clinton Avenue South to East Main Street and provide a "complete Street" facility that is properly scaled to the regional and local needs. The "complete street" design approach incorporates balanced pedestrian, bicycle and vehicle needs throughout the project corridor.

Approximately 120,000 cubic yards of clean fill will need to be imported to bring the project site up to the needed grade. The construction phase is expected to occur for more than one year. The sources of the needed fill, assurances and provisions to insure the fill is "clean fill" and not hazardous. The raising of the grade may also have an impact of stormwater and drainage collection and conveyance, as well as other public and private utilities.

Once the final grades have been obtained and the complete street design has been established, the Project will create development parcels that can accommodate up to 795,000 square feet of mixed-use real estate development. Given these project features, the following potentially

“moderate to large” impacts have been identified and are presented below in order to explain why that particular element of the proposed action will not result in a significant adverse impact:

- Construction Related Impacts,
- Import of Needed Fill Material;
- Stormwater and Utilities; and
- Future Development Related Impacts

Construction Related Impacts:

The single most notable construction-related impacts involve disruption to local travel patterns and construction-related noise impacts. Disruption to local travel patterns will occur as a result of temporary detours and congestion due to construction activities. While to some extent these impacts are unavoidable, they can be mitigated via proper signage for detour routes and continual updates to neighbors and businesses in the project area.

The construction activities will include excavation, sub-base preparation, roadway millings, placement of fill via dump trucks, and other miscellaneous work.

Construction noise will occur, however, construction noise differs from normal traffic noise in the following ways:

- Construction noise only lasts for the duration of the construction contract;
- Construction activities are usually limited to the daylight hours when most human activity takes place;
- Construction activities are generally short term; and
- Construction noise is intermittent and depends on the type of operation.

Certain mitigation measures can be incorporated into the contract documents to reduce construction noise in the project area. The following mitigation strategies are likely to be used for this project:

- Use of exhaust systems in good working order, engine enclosures and intake silencers;
- Regular equipment maintenance;
- Use of new equipment subject to new product noise emission standards;
- Placement of stationary equipment as far away from sensitive receptors as possible;
- Strategic choice of staging sites; and
- Limitations on work hours.

The project will incur similar construction related impacts, including dust as other City of Rochester transportation reconstruction projects have in the past. The contractor will be required to control construction generated air pollution as specified in Section 107-11 of the NYSDOT Standard Specifications – Air Quality Protection.

As with all City of Rochester roadway reconstruction projects, all construction related activities will be monitored during the entire construction phase for conformance by the City of Rochester Construction Division and consultant inspection staff to ensure that construction impacts are minimized.

Import of Needed Fill:

Fill material will come from other City of Rochester project sites, as well as from other private and public projects as needed. Given the unknown sources of most of the needed fill material at this time, assurances that the fill is both suitable and non-contaminated are needed.

The selected contractor will be responsible to acquire all materials required to the construction of the project. During construction, the contractor will be required to identify all material sources, which are also subject to approval by the City of Rochester.

The contractor will be required to control construction generated pollution as specified in Section 106 of the NYSDOT Standard Specifications – Construction and Materials, and Section 205 – Contaminated Soils. These standard specifications identify:

- A description of what soil contamination includes;
- Segregation and storage of contaminated soil encountered during excavation;
- Field Organic Vapor Monitoring;
- Sampling and Analysis;
- Transportation and Disposal; and
- Reuse of Contaminated Soil

During construction, all operations will be closely monitored by the consultant inspection staff. Should suspect materials be encountered, the inspection staff will notify the City of Rochester Department of Environmental Quality to ensure that proper measures are taken. In addition to the NYSDOT Standard Specifications stated above, the contractor can require sampling of suspect material in accordance with the NYSDEC "DER/10 Technical Guidance for Site Investigation and Remediation". More specifically, suspect fill material can be chemically tested to ensure that it does not exceed the allowable constituent levels for imported fill or soil provided in Appendix 5.

Stormwater and Utilities:

The raising of the grade throughout the project corridor will alter the existing storm sewer system. The collection and conveyance of stormwater will be change .

Drainage along the project corridor consists of a closed drainage system with drainage inlets along the medians and shoulders. The drainage system has various sizes and types of drainage conduit. The corridor contains curbing with the exception of the depressed Inner Loop mainline segments that utilizes concrete gutters adjacent to the retaining walls to convey surface flows to the drainage inlets.

The closed drainage system along the Inner Loop mainline drains to a storm sewer line that is in the center median of the Inner Loop. The storm sewer then discharges to the combined sewer system at both the north and south ends. The Union Street stormwater runoff generally flows north and continues along the Main Street corridor to the northeast. The Pitkin Street stormwater runoff drains into a storm sewer along Pitkin Street that outfall's into the combined sewer system as well. The Howell Street stormwater runoff flows toward Monroe Avenue and continues southeast along Monroe Avenue.

All of the existing stormwater drainage systems within the project limits connect to the combined sewer system before eventually discharging to the overflow tunnel system and then to the Van Lare sewage treatment facility.

The proposed Project calls for a reduction in the amount of impervious surfaces, with an increase in the amount of pervious surfaces. The entire project area (Inner Loop plus Right-of-Way) is essentially impervious today. The proposed project does call for a reduction in the amount of impervious surfaces, primarily from the incorporation of pervious surfaces in the redevelopment parcels (green space, lawn area, etc.) and pervious pavement used for the cycle track. It is difficult to quantify the amount of pervious surfaces at this juncture given that the specific location and amount of pervious surfaces will be determined by future developers and subject to site plan review/approval.

The existing drainage system is generally in fair working condition. There are areas however where the existing drainage structures are deteriorated due to wear and tear and therefore should be addressed, while other isolated areas on the pavement surface frequently pond during rain events due to imperfections in the pavement surface and/or inadequately positioned drainage structures.

The existing drainage system improvements will be limited to catch basin replacements, and supplemental catch basin installations where needed, to provide adequate roadway drainage throughout the corridor. The existing Inner Loop drainage system will be abandoned and a section of the existing combined sewer along the Inner Loop from Broad Street to Richmond Street will be relocated. In addition a 6" underdrain system with curb installed along the proposed curb line to enhance subsurface pavement drainage. Manhole frames and covers will also be replaced.

Future Development Related Impacts:

Once the final grades have been obtained and the complete street design has been established, the Project will create development parcels that can accommodate up to 795,000 square feet of mixed use real estate development.

Over the last 19 years, the City of Rochester has completed various initiatives focused on revitalizing the Center City and the surrounding neighborhoods in order to rejuvenate districts, thus providing for future economic opportunities in order to be able to compete in the global marketplace. These City initiatives have included:

- *The Vision 2000 Plan;*
- *The Neighbors Building Neighborhoods Program;*
- *City of Rochester's Inner Loop Improvement Study, 2001;*
- *Center City Master Plan, 2003;*
- *Rochester Regional Community Design Center – Charrette – A Community Based Vision Plan for Downtown Rochester, 2007;*
- *The Renaissance 2010 Comprehensive Plan;* and
- *GTC Long Range Transportation Plan*

During the initial Inner Loop Improvement Study, various land use evaluations were undertaken for the reclaimed land in the corridor that would be created. This land recovery allows for future

land use opportunities and the potential to physically and visually connect the Central Business District to the adjacent neighborhoods. The 2001 study identified opportunities for residential neighborhood extensions, commercial development, and open space, in the range of 9.4 acres of new land depending on the at-grade road alignment and width characteristics. Since then, various community initiatives have taken a serious look at desired land uses and densities, resulting in several recommendations surrounding the Southeast Loop area. The 2003 Center City Master Plan and the 2007 Downtown Charrette process helped to formulate a vision on the desired community characteristics that can be considered in this area, including the need to:

- *Create a major gateway at the east end of Main Street,*
- *Create new development sites for civic space, new development and parking,*
- *Create new infill development that complements the historic housing stock along South Union Street,*
- *Reconnect Monroe Avenue to downtown through the addition of continuous building frontages,*
- *Expand and improve Manhattan Square Park and create a major civic space in front of the Strong Museum,*
- *Extend Woodbury Boulevard to improve connections and new opportunities for infill development,*
- *Create new neighborhoods that provide a built-in-constituency for Manhattan Square Park and other downtown destinations,*
- *Narrow Broad Street to provide new building sites that would create a stronger public realm.*

The future development of these parcels will accomplish and promote the various community characteristics identified above. Each development parcel will be subject to review by the City of Rochester as developers come forward and site plans are prepared. Each development parcel will be reviewed for consistency with the Center City Master Plan and other applicable City codes.

Impact on Historic and Archaeological Resources

The following Cultural Resource Studies were completed for this project:

- Phase 1A Cultural Resource Survey for the Inner Loop East Reconstruction Project completed by the Department of Anthropology, State University of New York at Buffalo. (February 2013)
- Phase 1B Archaeological and Architectural Reconnaissance Survey for the Inner Loop East Reconstruction Project NY Route 940T completed by the Department of Anthropology, State University of New York at Buffalo. (May 2013)
- Phase 2 Archaeological Reconnaissance Survey for the Inner Loop East Reconstruction Project NY Route 940T completed by the Department of Anthropology, State University of New York at Buffalo. (December 2013).

According to the National Register (NR) of Historic Places, there are no historic properties eligible, or listed, within the project's area of potential effect.

A Phase I archeological survey was conducted to determine the presence of archeological resources. As a result of the survey, two (2) locations within the project area contained sufficient resources to declare them as being historic archeological sites.

The first site, referred to as the George Crouch site (A05540.009184) (UB4409), is located on South Union Street at the Howell Street intersection. Findings from shovel test pit explorations revealed the presence of past domestic refuse. However, considering that the proposed impacts to this area consist of shallow excavations associated with sidewalk installation, monitoring of excavations for potential unexpected artifacts during construction would be sufficient.

Artifacts associated with the G. Crouch site were recovered within both fill and partially disturbed natural horizon soils from a low-to-moderate density broadcast midden scatter identified within topsoil, fill and buried A-Horizon contexts. These materials included a variety of early-19th to mid-20th century ceramic and glass food related artifacts, as well as a number of highly oxidized ferrous metal fragments believed to be nail fragments. However, due to the site's position relatively far away to the northwest of the associate historic map documented structure; it is difficult to directly associate these remains to the G. Crouch site's documented residential occupants. It is most likely that many of these artifacts were deposited in the form of roadside debris.

Based on these results, the site's research potential has been exhausted by the combined Phase 1B / Phase 2 testing procedures that have already been completed. Further, the G. Crouch Site does not appear eligible for listing on the National Register of Historic Places. No further archaeological investigations are recommended, however, construction monitoring is recommended to protect this site.

The second site, referred to as the Amos Burrows site (A05540.009185) (UB 4410) is located at the Pitkin Street/Savannah Street intersection. Findings from shovel test pit explorations also revealed the presence of past domestic refuse. This location will also experience shallow excavations associated with sidewalk construction, and as such monitoring of excavations for potential unexpected artifacts during construction would be sufficient.

A Phase II archaeological survey was conducted to more precisely determine the locations, quantity and significance of the resources. This investigation recovered several small fragments of past domestic refuse. The report concludes that no further subsurface investigation is warranted and therefore a Determination of No Effect from the NYS Office of Parks, Recreation and Historic Preservation is anticipated.

Based on preliminary results, the Amos Burrows site appears eligible for listing on the National Register of Historic places, due to the recovery of both temporally and functionally diagnostic mid-to-late 19th century domestic artifacts in good context that represent an urban domestic site. Due to the site's small size and the fact that the majority of the first period historic feature was completely removed during the site examination, the site's research potential has been exhausted. While no further archaeological excavation is recommended at the Amos Burrows site, it is possible that contextually associated materials and/or features might be found beneath the paved parking lot and driveway between Savannah and Pitkin Street. Construction monitoring was also recommended to protect this site.

An archaeologist from SUNY Buffalo, Department of Anthropology will be present when construction takes place at both of these two sites. The archaeologist will observe the

excavation in these areas, determine if artifacts are present, and if so, determine if collection of the artifacts is warranted and other determine if other remedial steps are pertinent.

Impact on Transportation

The proposed transformation of the Inner Loop expressway to an at-grade urban city street will have little to no impacts on the overall transportation system. The proposed traffic increases will be accommodated by the new roadway system and network; intersection operations are shown to meet design criteria. The new urban city street will have adequate travel lanes, turn lanes and traffic control to accommodate the traffic at each intersection location. Numerous intersection geometric and traffic control options were assessed and are documented in the Inner Loop East Transformation Project Draft Design Report. While travel speeds may be lower on the city street than on the previous expressway, overall traffic operations should function better on the street network and accessibility for pedestrian and bicycle traffic will be notably improved. Levels of operations at each of the corridor intersection are projected to be LOS C or better.

The overall street grid system will be notably enhanced with additional cross street connections. The new urban street will allow for the reconnection of Charlotte Street; the ultimate reconnection of Haags Alley; and allows for the future Woodbury Boulevard extension. Each of these new connections provides improved connectivity and breaks up the various superblocks. This creates a more livable and walkable community providing substantial social benefits.

The project will significantly improve pedestrian and bicycle travel with the addition of a cycle track, the addition of on street bike lanes, a contra flow bike lane, sharrows and bike boxes. For pedestrian travel, additional midblock and intersection crossing locations are provided. Each intersection geometric design has minimized the width travelled to improve pedestrian access and safety. While the project may alter travel patterns in the immediate area, these changes will be positive changes as the urban city street will provide two-way traffic operations along with additional street grid connections. Each of the various elements of the project significantly improves livability, connectivity and mobility.

Lastly, the transformation from a high speed expressway to a low speed city street will have a positive effect on safety and access for all users while enhancing livability for current and future residents. It is anticipated that the severity of accidents that occurred on the Inner Loop expressway will be reduced when the expressway traffic is combined with Union Street traffic on the new lower speed street. Additionally, all of the expressway non-standard and non-conforming features will be eliminated from the network.

Impact on Energy

The proposed project will create development parcels that can accommodate up to 795,000 square feet of mixed-use real estate development. The mixed-use development could include a mixture of residential units, office space and retail use. This new development will generate the

need for natural gas and electric service from Rochester Gas and Electric Corporation. Natural gas and electric services are readily available throughout the project corridor. The projected increase in energy is not expected to require a new, or an upgrade to an existing substation. Therefore, the project is not expected to result in a significant adverse environmental impact.

The City of Rochester and the design consultant will continue to be in contact with Rochester Gas and Electric Company regarding the placement and connections to natural gas and electric lines.

Based upon this evaluation of potential environmental impacts, along with the incorporation of the identified mitigation measures, the Project is not expected to result in any significant adverse environmental impact.

APPENDIX E

Non-Standard Feature Justification Forms

Main Line Design (in accordance with HDM §2.7)			
PIN:	4940.T7	NHS (Y/N):	No
Route No. & Name:	Howell Street	Functional Class:	Urban Minor Arterial
Project Type:	Reconstruction	Design Classification: (AASHTO Class)	Urban Arterial
% Trucks:	2%	Terrain:	Level
ADT:	9,500	Truck Access Route:	No
1. Description of Nonstandard Feature			
Type of Feature:	Superelevation		
Location:	Sta. HSE 16+00 to Sta. HSE 17+15		
Standard Value:	4%	Design Speed:	30 mph
Existing Value:	NC	Recommended Speed:	25 mph
Proposed Value:	NC	Recommended Speed:	25 mph
2. Accident Analysis			
Current Accident Rate:	NA		
Statewide Rate (based on similar type highways):	NA		
Is the nonstandard feature a contributing factor?	<input type="checkbox"/> Yes		<input checked="" type="checkbox"/> No
Anticipated Accident: Rate / Severity / Cost	Due to this curve being located at the terminus with Union Street, it is anticipated that motorists will be traveling below the recommended speed.		
3. Cost Estimates			
Cost to Fully Meet Standards:	NA		
Cost(s) For Incremental Improvements:	NA		
4. Mitigation (e.g., increased superelevation and curve warning signs for a nonstandard horizontal curve):			
	The curve will be designed to meet clear zone requirements.		
5. Compatibility with Adjacent Segments & Future Plans:			
	These improvements will be compatible with adjacent segments and future plans.		
6. Other Factors (e.g., Social, Economic & Environmental):			
	Due to the close proximity of adjacent buildings, meeting the 4% Superelevation rate would create excessive cross slope issues for sidewalks and building thresholds along this segment of roadway.		
7. Proposed Treatment (i.e. Recommendation):			
	The close proximity of the curve to the intersection does not allow for proper super elevation transitions. In addition, the super elevation rate meets the requirements of a 25 MPH design speed that is more consistent with the travel speeds anticipated within this speed transition area due its close proximity to the Union Street intersection. Therefore, it is recommended to construct the non-standard feature.		

